

TANDBERG® TPA 3006 A

Circuit Diagram and Alignment Instructions

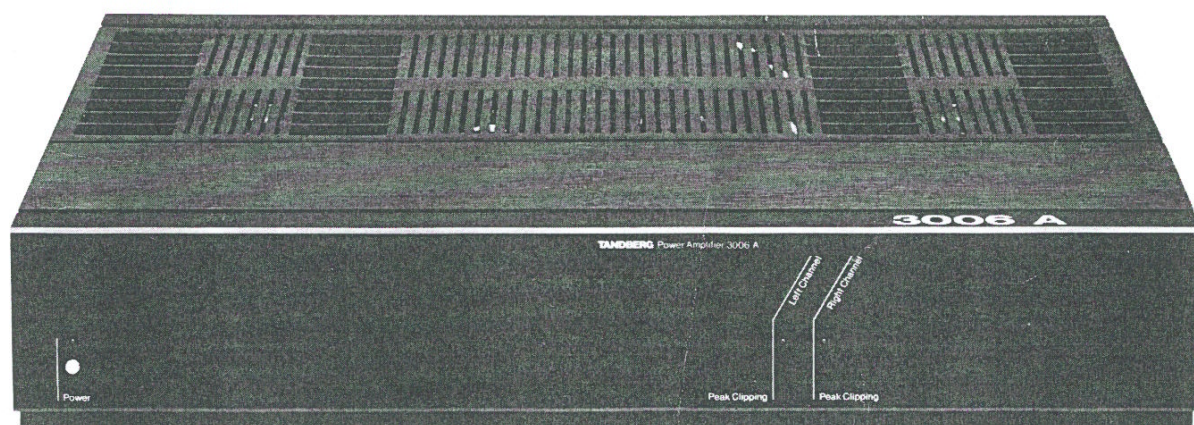

To serial No. 01000

Dismantling

- Top cover, rear (1)
- Top cover, front (2)
- Rear panel (3)
- Front panel (4)
- Bottom cover (5)

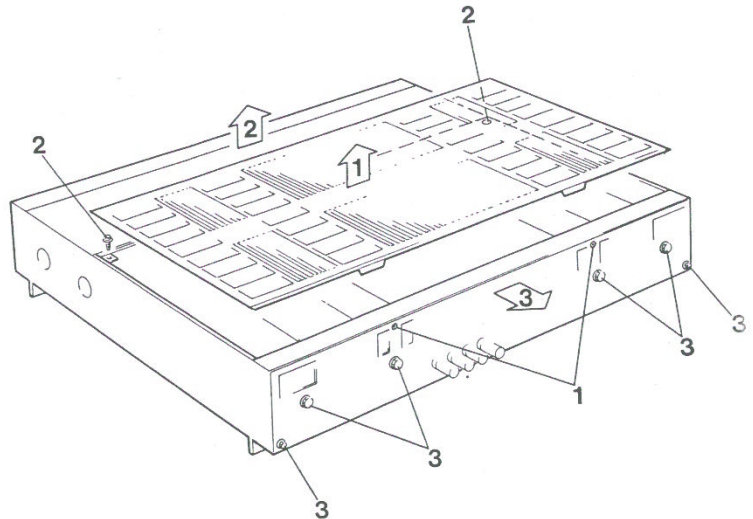

Dismantling the rear and top covers.

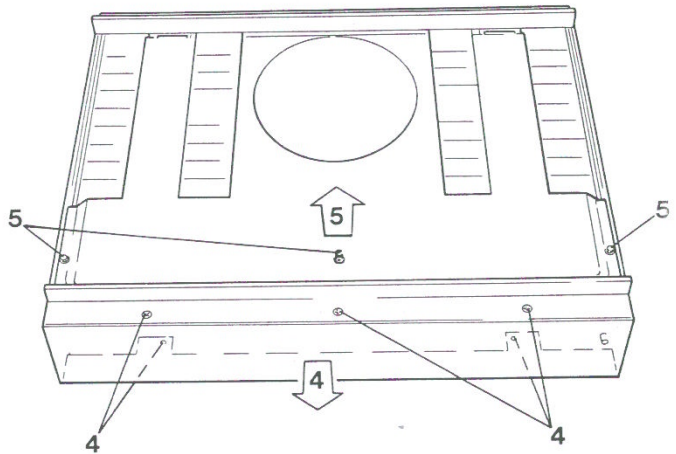

Dismantling the front and bottom covers.

Adjustments

Test condition

Approx. 10 minutes warming up time without signal applied. The top and bottom cover should not be removed, otherwise the unit must be covered.

D.c. offset adjustment

- Solder two LED's (light emitting diodes) with opposite polarity together in parallel and connect them to the contacts J106 (left) and J206 (right) on the power amplifier boards (collectors on Q111/Q112 left and Q211/Q212 right).
- Adjust R104 (left) and R204(right) until both LED's are switched off.
- Remove the LED's and measure the d.c. voltage on the output terminals. The d.c. voltage should be less than ± 50 mV.

Quiescent current

The quiescent current should be adjusted without load and the volume control must be set to minimum.

- Adjust R171 (left) and R271 (right) on the output amplifier boards to 35 mV across R505 (left) and R605 (right) on the power supply board.

Distortion

Apply a signal of 1 kHz and drive the amplifier to 12 V on the output terminals when the load is 4 ohms.

- Adjust R163 (left) and R263 (right) to minimum distortion. The distortion should be less than 0.005%.

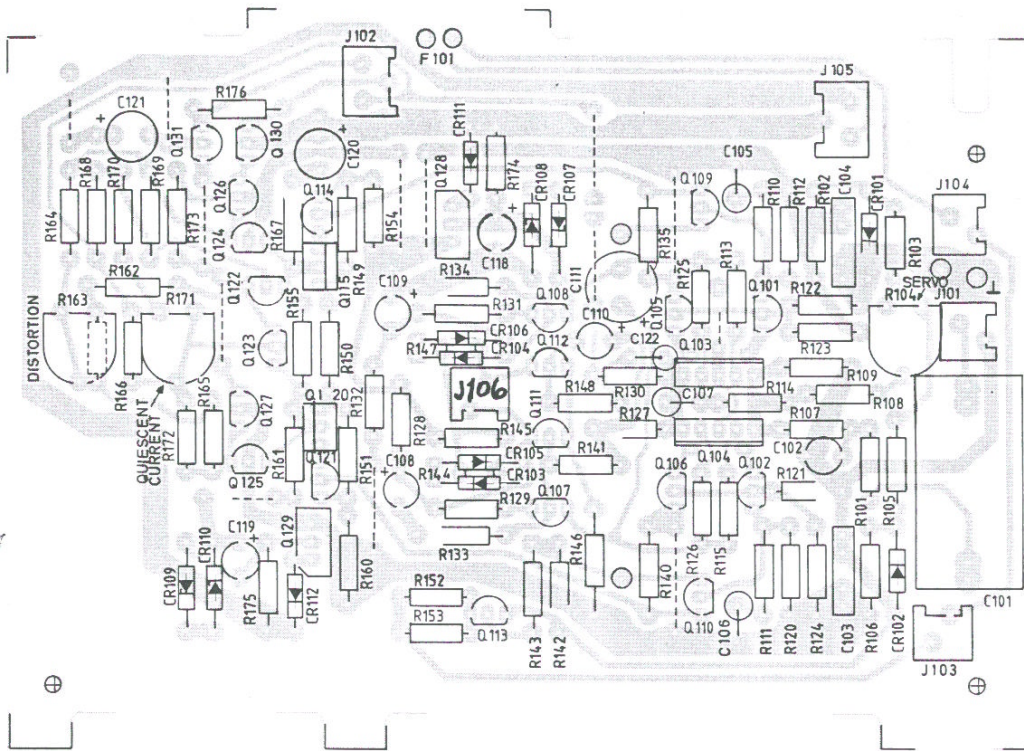

Power amplifier board, left channel, component side

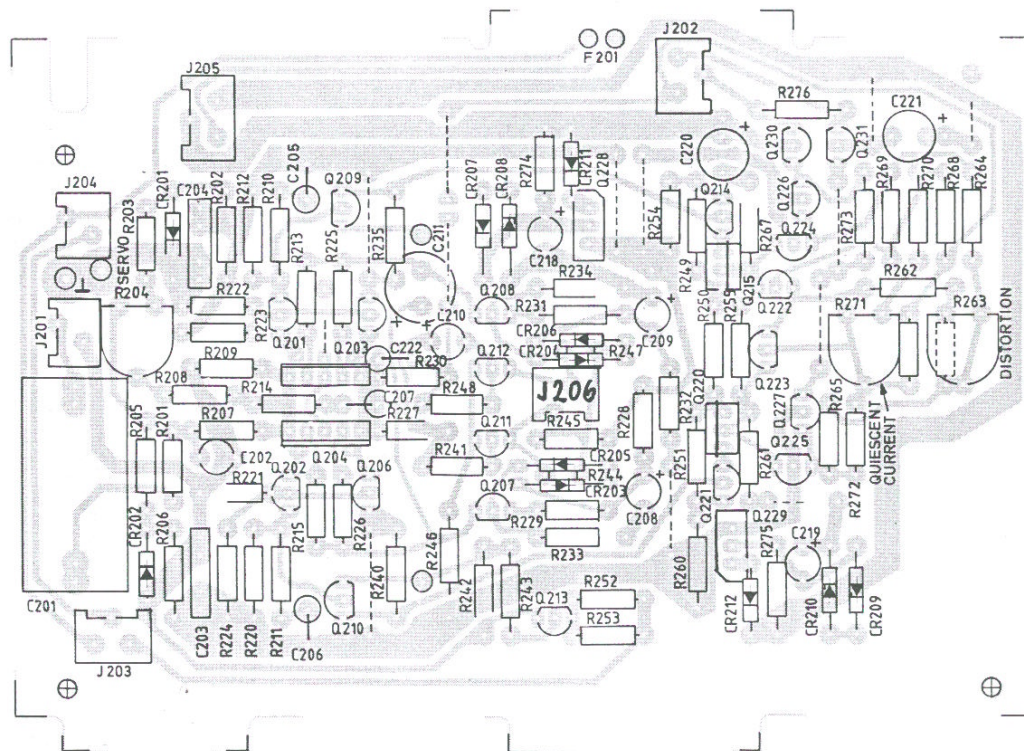

Power amplifier board, right channel, component side

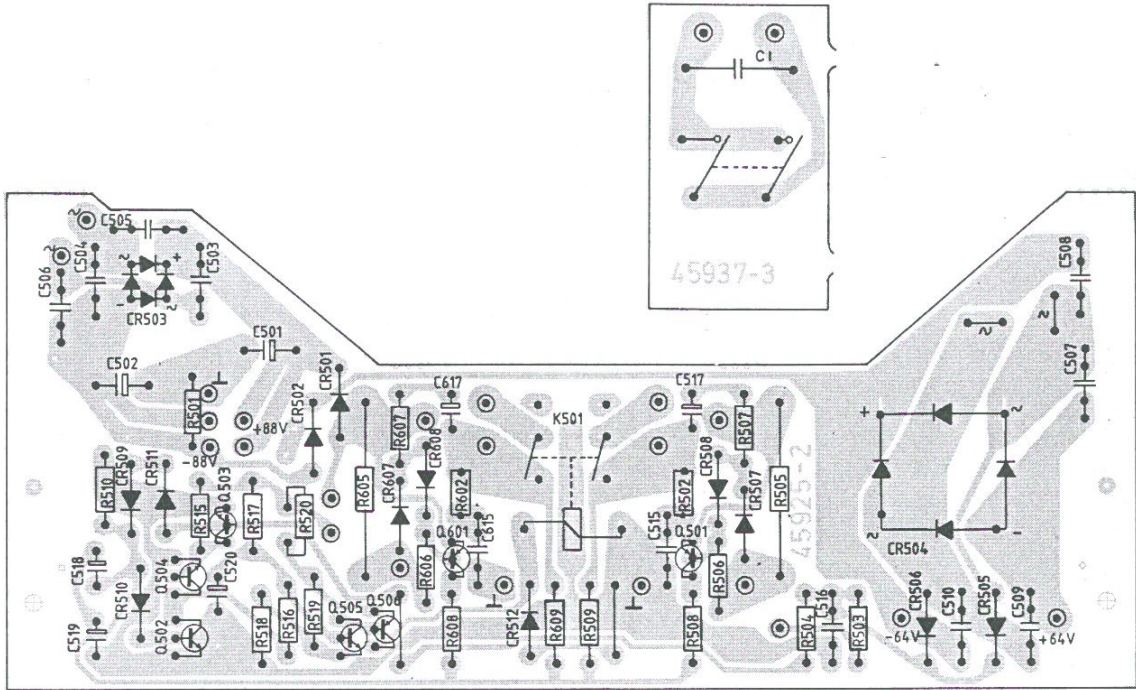

Power supply board, solder side

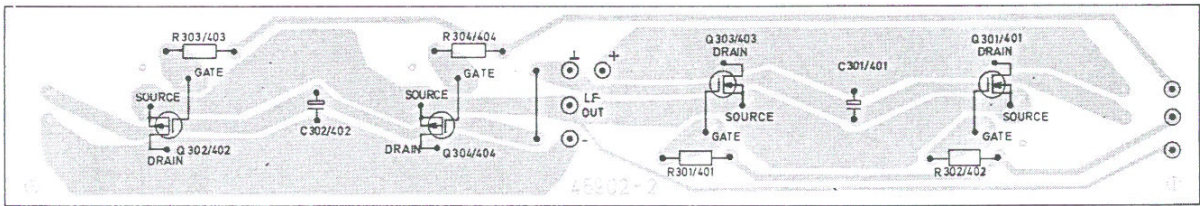

Output power amplifier board, solder side

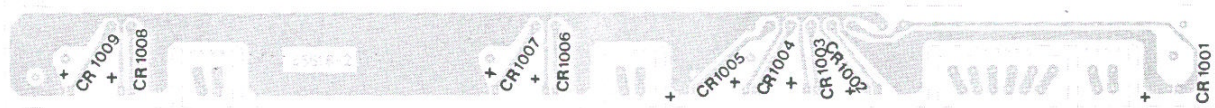

LED board, solder side

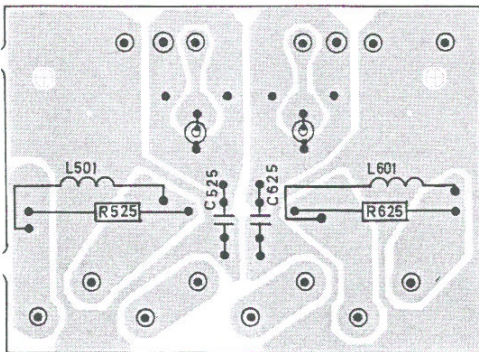

Input board, solder side

Checking the speaker protection relay

- Disconnect speaker load.
- Apply 6 to 8 V d.c. with 220 kohm in series (+ and – alternately) to R508/R509. The relay should then open.

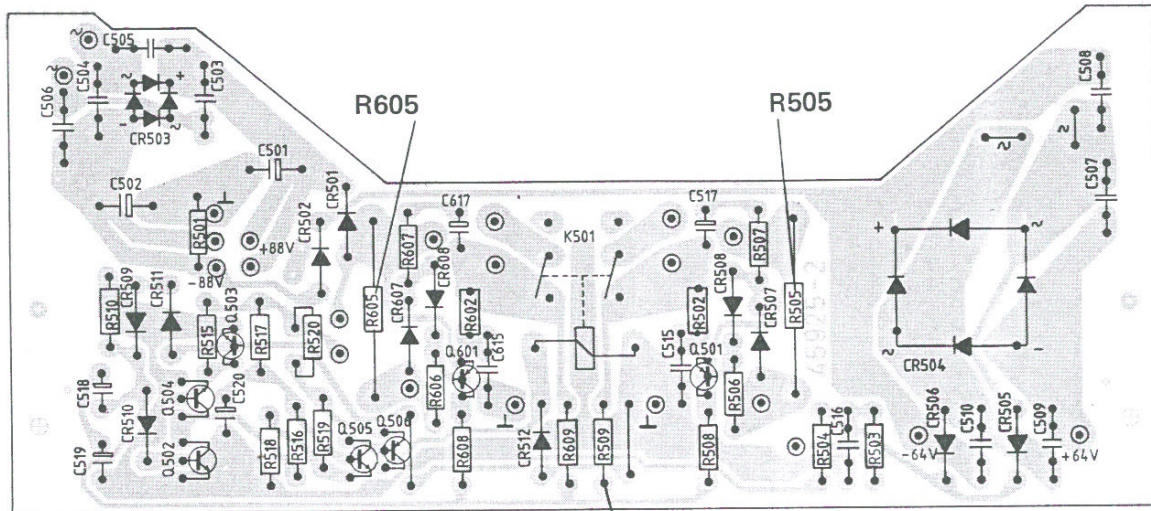

The power supply board seen from the component side.

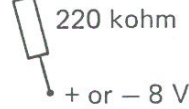

Tandberg Power Amplifier TPA 3006 A

Technical Data

Power requirements: 115/230 V \pm 10%, 50/60 Hz
Power consumption: 50 – 770 W
Dimensions: Width: 17 1/8" (43.5 cm)
Depth: 13 3/4" (35.0 cm)
Height: 3 3/4" (8.3 cm)
Weight: 25 lbs (11.3 kg)

Technical Data according to IHF-A-202, 1978

Continuous Average Power Output:
(8 ohms, 20 – 20.000 Hz, THD < 0.02%)
2 x 150 W
Frequency Response: 20 – 20.000 Hz, + 0/– 0.2 dB
Sensitivity: 80 mV
A-weighted Signal-to-Noise Ratio:
(Ref. 1 W/8 ohms) 96 dB

Secondary Disclosures

Output Impedance (20 – 20.000 Hz): 0.07 ohms
Wideband Damping Factor: 120
Low Frequency Damping Factor: 200
SMPT E Intermodulation Distortion: 0.02%
IHF Intermodulation Distortion: 0.02%
Transient Overload Recovery Time: Immeasurable
Reactive Load Factor: 1.2
Reactive Load Rating: 0.8 dB
Separation: > 75 dB
Difference of Frequency Response: < 0.1 dB

Other Technical Data

Frequency Response: 1 – 150.000 Hz + 0/– 3 dB
Output Impedance (20 – 1000 Hz): 0.04 ohms
Slew rate: > 500 V/ μ S
A-weighted Signal-to-Noise Ratio:
(Ref. 150 W/8 ohms) 118 dB

o Specifications are subject to change for further improvement without notice.

Tandberg A/S
Fetveien 1, P.O. Box 53
N-2007 Kjeller, Norway

