

TANDBERG

TD 20 A

Service Manual



Contents

	Page
General	3
Dismantling the cabinet.	3
Removing the black top cover.	3
Replacing the black top cover.	3
Removing the meter panel.	4
Replacing the meter panel.	4
Mechanical checks and adjustments.	4
Checking the braking force	4
Adjusting the braking force.	5
Checking the pinch roller pressure.	5
Tape tension arms	6
Changing the drive belt	7
Adjusting the thrust-bearing for the capstan	7
Changing the tape-counter belt	7
Changing the worm-gear motor	8
Changing the capstan motor	10
Changing the reel motor	10
Changing and adjusting the microswitch	11
Maintenance	12
Cleaning the tape path.	12
Degaussing.	12
Lubrication	12
Tape path adjustments and head adjustment.	13
Adjusting the tape path.	13
Adjusting the parallelism.	13
Left tape tension arm	14
Tape guide posts	14
Pinch roller	15
Checking and re-adjusting the flutter roller.	15
Head alignment with Tandberg test tapes, four track	16
Head alignment without Tandberg test tapes, four track	17
Head alignment, two track	18
Record and playback curves, NAB	19
Checking the record and playback curves, IEC	20
Fault in the total response curve, one channel.	21
38 kHz filter in record amplifiers	22
EOT/BOT sensor (end of tape/beginning of tape)	22
Power On/Off circuit.	23
TMI sensor (tape motion indicator).	23
Control circuit for reel motors	24
Worm-gear motor	25
Logic Circuits	26
The a-synchronous logic circuit.	27
The PROM control unit.	27
Electrical adjustments	28
Circuit diagrams and P.C. boards.	30

General

- * Only Maxell UD XL or equivalent tapes should be used for recording. Make sure that the heads and tape path are clean.
- * To check the heads, simply remove the two head covers. They should be pulled straight off.

When electrical adjustments are to be made, the cabinet must be removed.

NOTE! Do not lay the TD 20A down on the front.

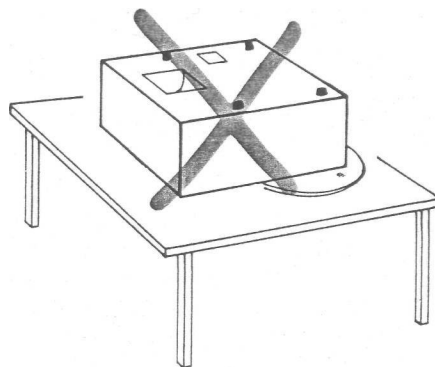

DO NOT lay the TD 20A down on its front

Dismantling the cabinet

WARNING! Do not lay the tape deck face down because the reel locks could be damaged.

Lay the tape deck on its back.

Remove the four cabinet screws as shown in the figure and lift the tape deck up.

Press on the four rubber feet on the back and pull the deck out of the cabinet.

To remove the head covers, pull them straight up.

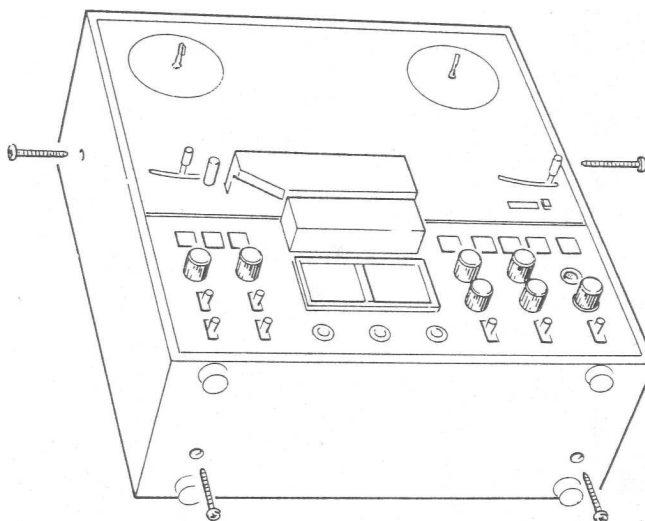

Cabinet screws

Removing the black top cover

Remove the six screws as shown in the adjacent figure. Turn the fork on the right tape tension arm and lift the top cover.

Replacing the black top cover

When the top cover is replaced, the projections in the plastic mouldings must fit into the holes in the meter panel. Centre the top panel around the reel turntables and secure it with screws A in the figure. Press the panel down and screw in the four side screws. Check that the tape tension arms do not touch the top cover.

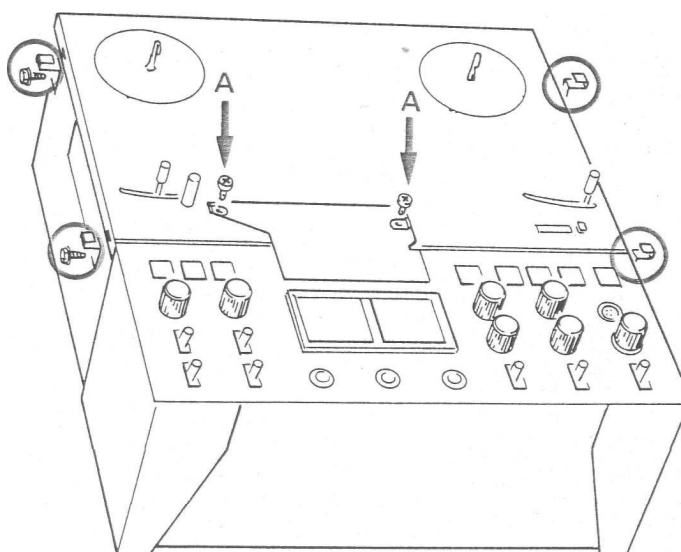

Removing and replacing the black top cover

Removing the meter panel

- Turn all knobs to 0 position.
- When the knobs are pulled off the Master Control knob must not be mixed up with the other knobs because it is deeper inside.
- Unscrew the plastic nuts on the Output/Input controls and pull off the plastic washer round the Master Control knob.

The meter panel is sealed to the chassis by lacquer at two points. Break the seals carefully.

Replacing the meter panel

When the meter panel is fastened, check that the panel makes no mechanical noise in Wind and Rewind. If necessary, seal the panel to the chassis with some lacquer at the two points shown in the figure.

Mechanical checks and adjustments

Checking the braking force

The tape deck should be in the Stop mode or the Power switch should be off.

A 7" reel with a hole drilled in it 80 mm from the hub hole is required together with a torque gauge. Lay the reel on the left or right turntable.

Insert the leg of the torque gauge into the drilled hole and try to turn the reel with the gauge. When the gauge overcomes the braking force, note the force in gauges. The force should correspond to that shown in the figure. Check both brakes in both directions.

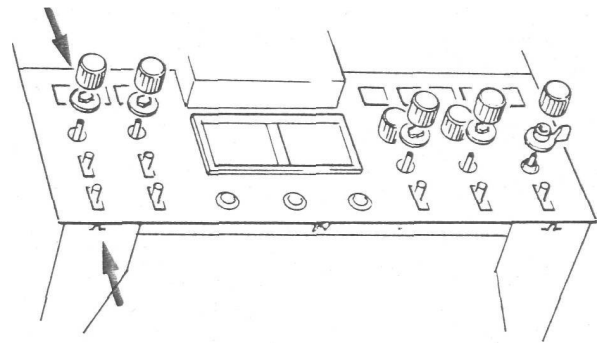

Lacquer points

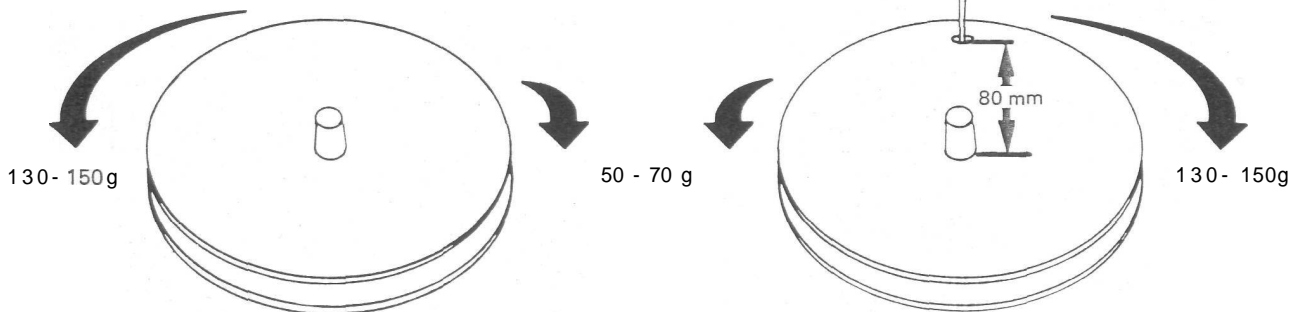

Checking the braking force

Adjusting the braking force

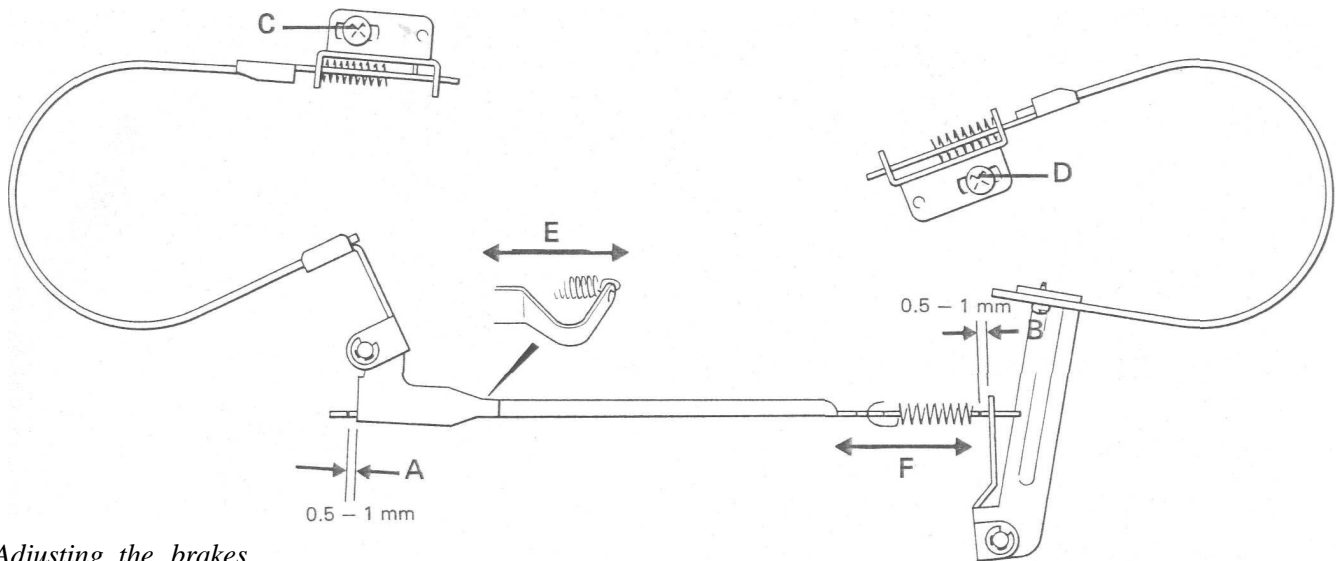

Adjusting the brakes

adjusting the braking force, check that the clearances A and B in the figure are between 0.5 and 1 mm. The clearances can be adjusted with screws C and D when the machine is in the Stop mode or the Power is switched off.

If the braking force is not correct it should be adjusted as explained in the next paragraph.

Adjust the braking force on the left turntable by bending the arm E in the figure to make it longer or shorter. The tighter the spring and the greater the braking force.

Adjust the braking force on the right turntable by moving spring F to another notch as shown in the figure.

Checking the pinch roller pressure

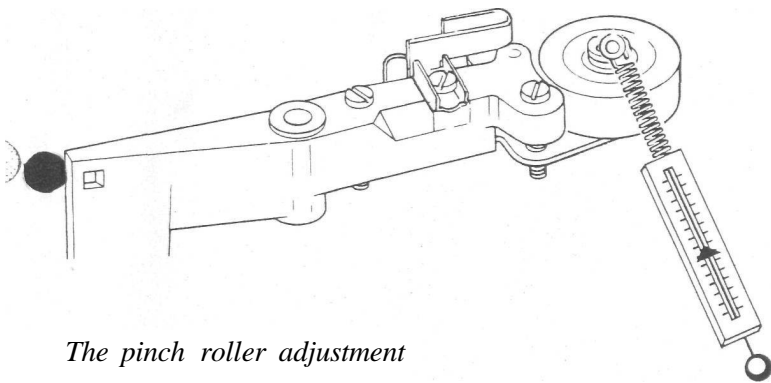

The pinch roller adjustment

To check the pinch roller pressure simply place a gauge on the pinch roller shaft when the machine is in Play mode. Press away from the capstan and when the pinch roller stops, the indication on the gauge should be approximately 1.3 to 1.5 kg.

Adjust the pinch roller pressure by moving the spring to another slot in the slotted arm, and by moving the motor bracket. See page 10.

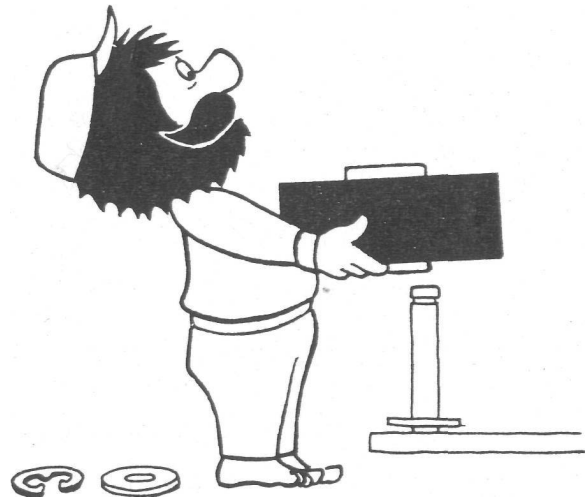

The pinch roller

When the pinch roller is changed make sure that the same number of "turbax" washers are on each side of the roller.

Then check that the tape runs in the middle of the roller without flickering on neither side of the roller.

Tape tension arms

Right tape tension arm

- Check that the arm (without tape) lies right out to the right-hand side. See figure.
- If not, check that springs B and C are in place.

Adjusting the height

NOTE! Manufacturing tolerances in 10½" reels can cause the tape to touch the outer side of a reel. Rubber washers, which are supplied with the TD 20A, should then be inserted between the reel turntable and the reel.

- Put on a full 7" reel.
- Adjust the height with screw A so that the tape does not touch the sides of the reel.

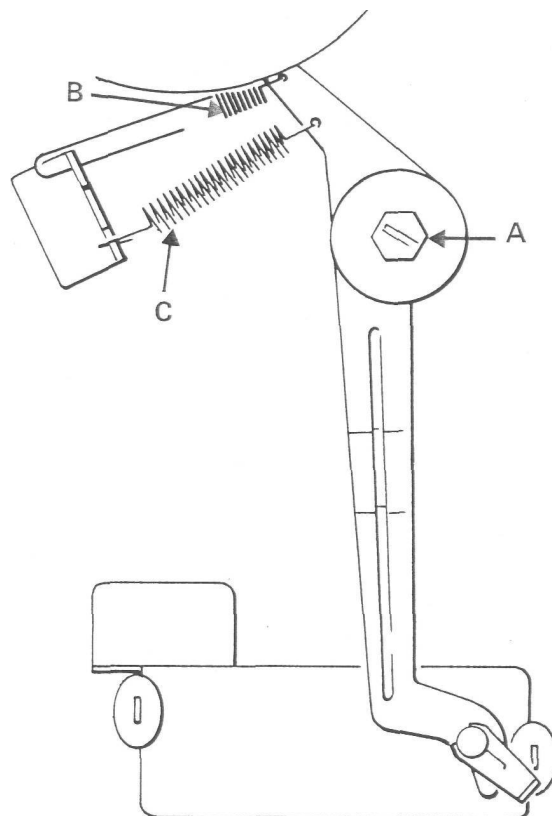

Right tape tension arm

Left tape tension arm

NOTE! The height must not be adjusted since it affects the adjustment of the tape path.

Adjusting the tape tension (servo brakes)

Set the tape deck in the Play mode (without tape).

- With the tape tension arm in the right-hand position, the servo-brake belt should not touch the reel turntable.
- With the tension arm about 11 mm from the right-hand position, the servo brake should begin to work.
- The braking effect can be adjusted in the following manner:
 - Bend arm D inwards or outwards.

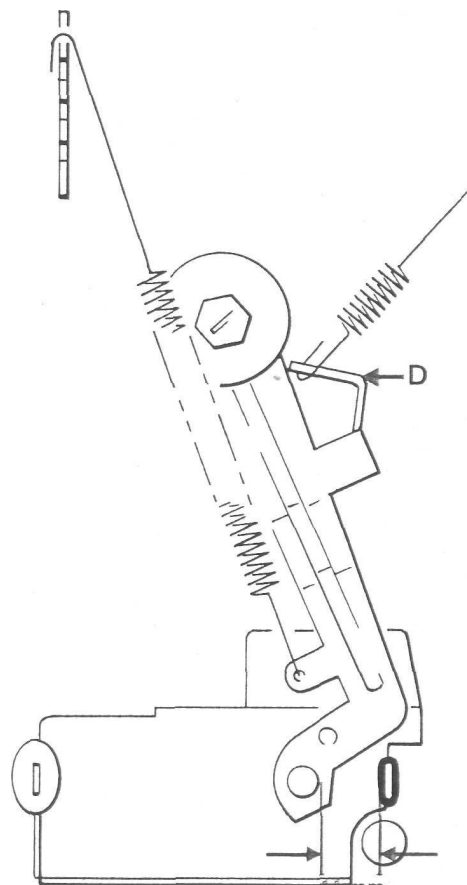

Left tape tension arm

Changing the drive belt

- Remove the split-pin, metal washer, and rubber washer from the pinch roller arm.
- Unscrew the three screws holding the tape path plate.
- Make sure that the capstan does not fall into the bearing and the plastic washer does not fall off when the tape path plate is lifted up. When the tape path plate is assembled, the plastic washer must be pushed right down on the capstan against the bearing.

NOTE! Make sure that no grease gets onto the new drive belt.

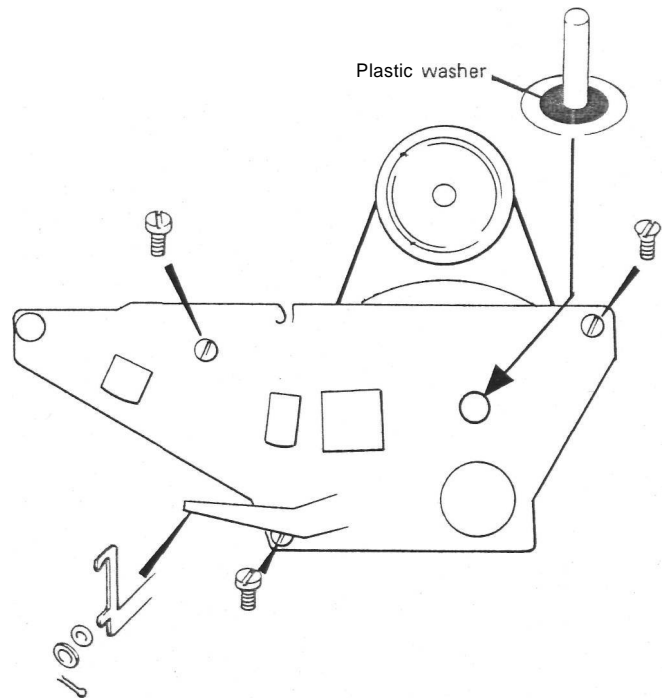

The tape path plate

Adjusting the thrust-bearing for the capstan

- Adjust screw A until the bearing touches the capstan.

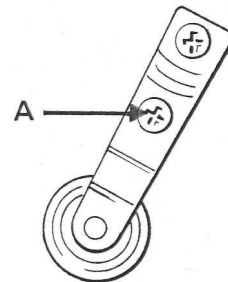

The thrust bearing

Changing the tape-counter belt

- Remove screw A on the counter bracket.
- Remove screw B on the sensor arm and pull the arm forward.
- Use tweezers or a spring-hook to bring the new counter belt in between the brake band and the right-hand reel turntable.
- Assemble to sensor arm so that it does not touch the reel turntable.
- Assemble the counter with the new drive belt into place and tighten screw A.
- Replace the black top panel and centre the counter with the aid of screws A and C.

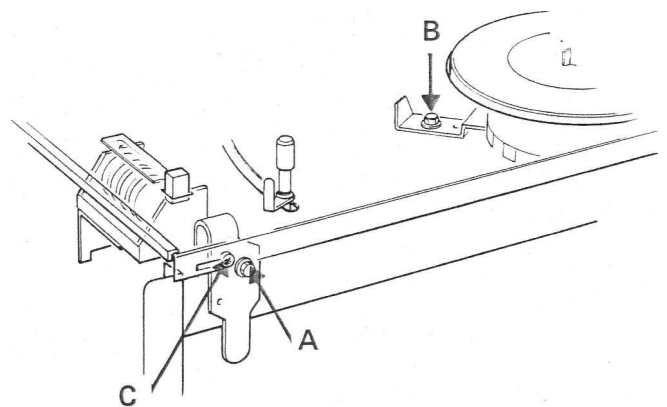

The sensor arm and the counter screws

Changing the worm-gear motor

Dismantling

Take note of which slot is used to retain spring A in the slotted-arm B. Remove the spring.

Remove split-pin D, the metal washer, and the rubber washer.

Remove circlip B and the fibre washer. Pull the plastic sleeve off the spindle.

Free the transfer arm on the pinch roller.

Remove screw E from the thrust bracket.

Remove screws C.

Free the motor leads and lift out the motor bracket, taking care not to damage the microswitch.

When the old motor is unscrewed from the bracket pull the screen (with nylon band) off the motor away from the leads.

Push the screen with the nylon band onto the new motor. Make sure that the join in the nylon band is pointing down (inside the hole in the chassis) when the motor is screwed up tight.

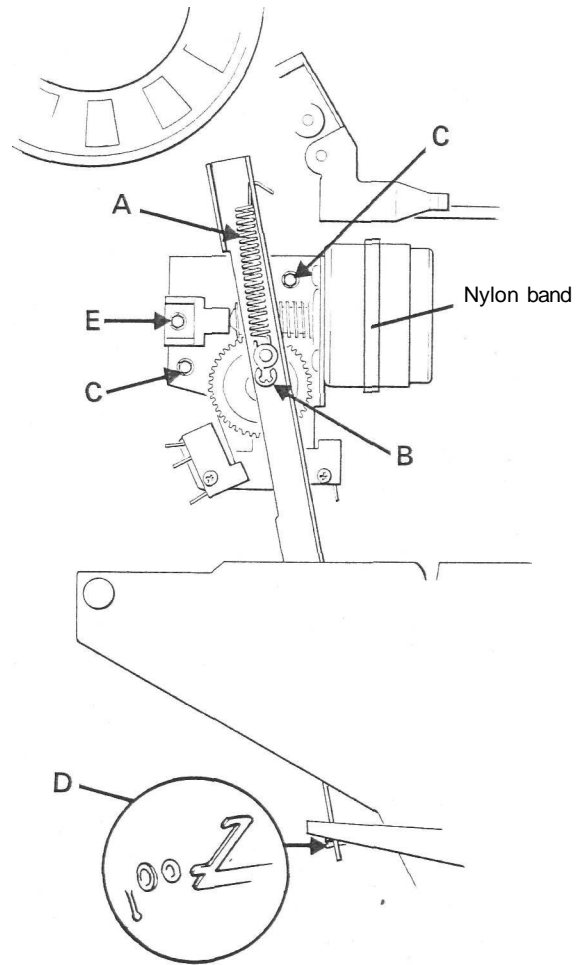

Dismantling the worm-gear motor

Assembling

Before the motor with bracket is fixed to the chassis in the tape deck the following steps must be taken:

Turn the worm-gear wheel so that the spindle for the transfer arm is towards the worm-gear motor. See the figure.

Press the motor spindle (worm-gear screw) into the motor so that it does not move (no slack). In this position push the motor into the screw holes until there is a small clearance between the worm-gear screw and the worm-gear wheel. Too much clearance causes more wear in transfer. Tighten the screws A fixing the motor to the bracket.

— When the motor bracket is fitted to the tape deck ensure that the guide lugs on the bracket go into the guide holes in the chassis.

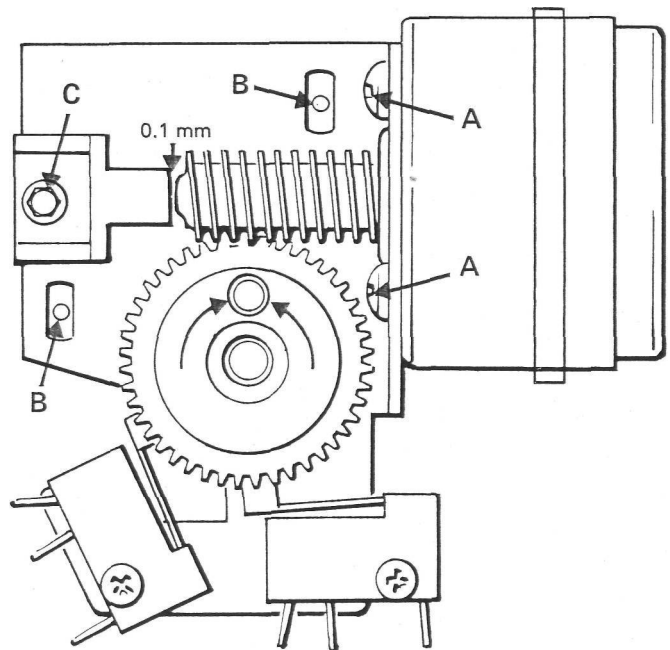

Adjusting the worm-gear motor

- Move the motor bracket so that the screw holes in the chassis are aligned with the holes in the motor bracket. Tighten up the screws B fixing the bracket to the chassis, see page 8.
- When the clearance between the thrust bracket and the worm-gear screw is 0.1 mm, tighten screw C in the bracket. Use a feeler gauge or a piece of ordinary writing paper.
- Fix the transfer arm.
- Fit the plastic sleeve (flat side up), fibre washer, and circlip onto the spindle.
- Fit the rubber washer, metal washer, and split-pin for the transfer arm.

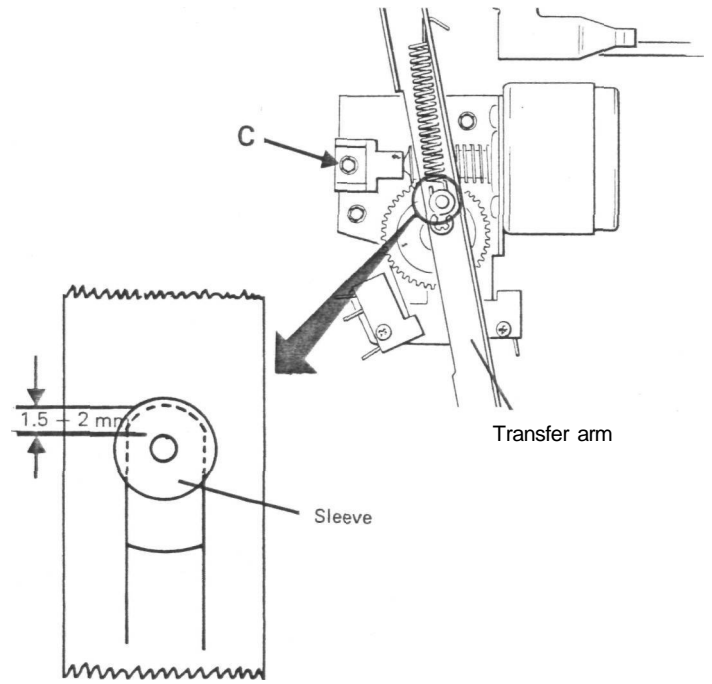

IMPORTANT!

- Switch the tape deck to Play or Record. Check that there is a clearance of 1.5 to 2 mm between the spindle on the worm-gear wheel and the transfer arm for the pinch roller (the long hole in the arm should be edge-to-edge with the plastic sleeve). See the figure.
- To adjust the clearance, first loosen the worm-gear bracket. Then move the bracket until the clearance is correct, then tighten the screws in the bracket. Check that the pressure of the pinch roller onto the capstan is between 1.3 and 1.5 kg. To adjust the pinch roller pressure, move the worm-gear bracket (remember the clearance) or move the spring to another slot in the slotted-arm.
- If the worm-gear bracket is moved too far over, it can cause the tape to touch the erase head and record head when the tape deck is switched from Stop to Wind/Rewind (minimum distance). To correct this situation, adjust the arm which presses against the pinch roller (see figure). This arm must not be bent too much because it can cause the tape to touch in the endstop unit when the deck is switched from Play/Record to Wind/Rewind (maximum distance).

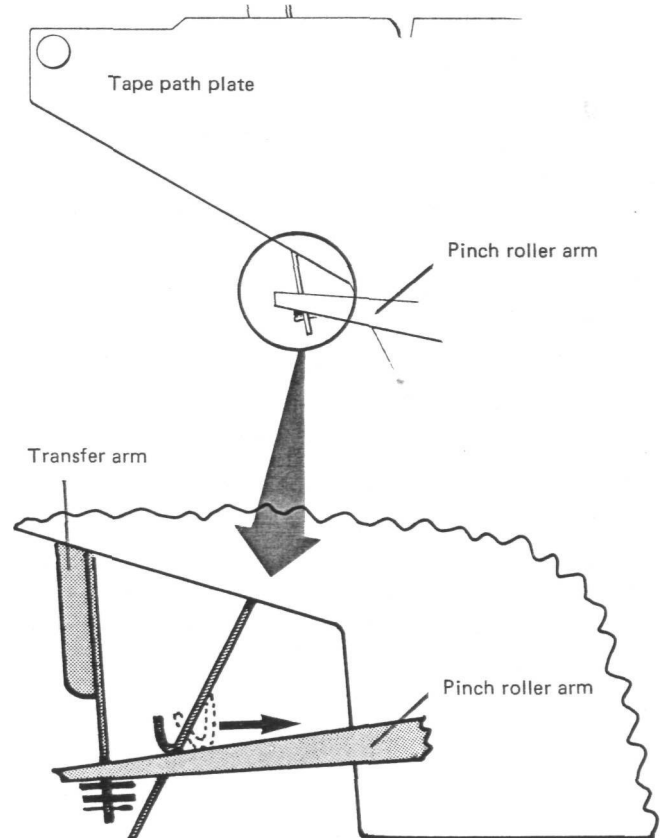

Adjusting the transfer arm

Changing the capstan motor

- Use a pair of calipers or a gauge to measure the distance from the top of the motor pulley to the chassis. See figure.
- Remove the circlips from the motor pulley and pull the pulley off.
- Take out the four screws that hold the capstan motor.
- After the new motor has been fitted, replace the motor pulley at the distance from the chassis shown by the calipers when it was removed.
- Fix the circlip for the motor pulley so that the openings in the clips are 90° displaced. See figure.

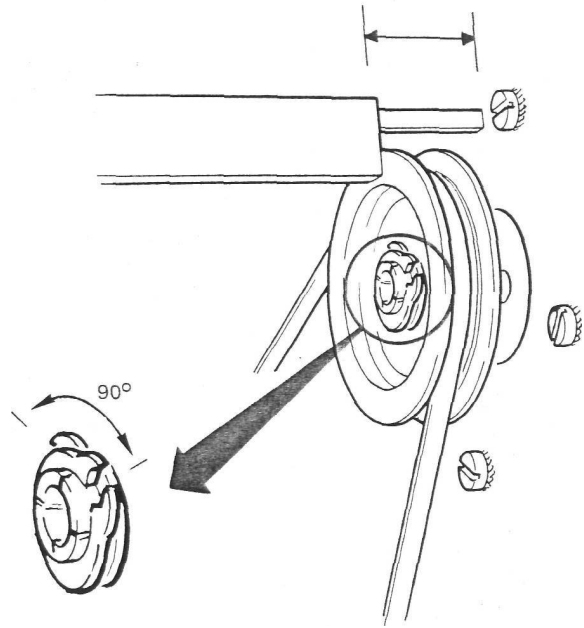

Motor pulley with circlips

Changing the reel motor

- Measure the height from the top of the reel turntable to the chassis.
- Use a thin screwdriver and loosen the two set screws on the reel turntable.
- Pull off the turntable.
- Remove the four screws holding the reel motor.
- After the new motor has been fitted, replace the turntable at the height given by the calipers or gauge when it was removed. Check that the turntable is sitting correctly (pay particular attention to the right-hand side).

NOTE! Manufacturing tolerances in 10½" reels can cause the tape to touch the outer side of the reel. To overcome this problem, fit the rubber washers (provided with each TD 20A) between the turntable and the reel.

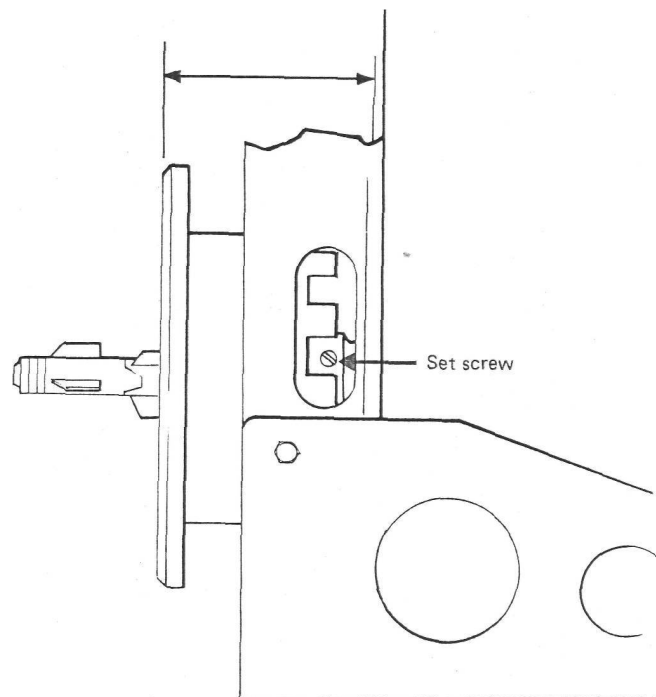

Set screws for the turntables

Changing and adjusting the microswitch

If the microswitches must be changed it is very important that they are replaced correctly because they control all operations in the deck.

- When a new switch is fitted make sure that the switch arm fits into the backmost holes. See figure.
- First fit the switch parallel with the bracket. DO NOT tighten the screws!
- Turn the worm-gear until one of the high points on the cam touches the microswitch.
- Adjust the switch so that it operates (clicks) in the middle of the slope up to the high point on the cam.
- Check the switch setting by making sure that the switch arm has play up and down the slope on both sides of the click.

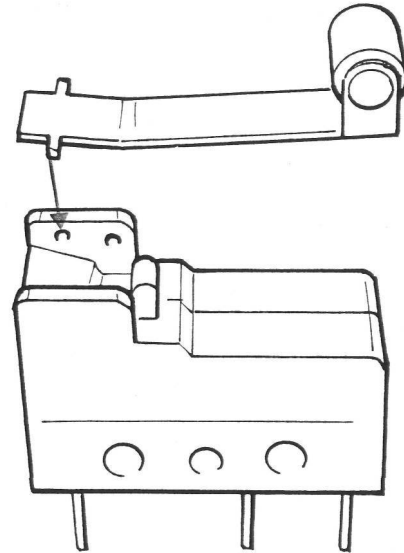

Microswitches XO and X1

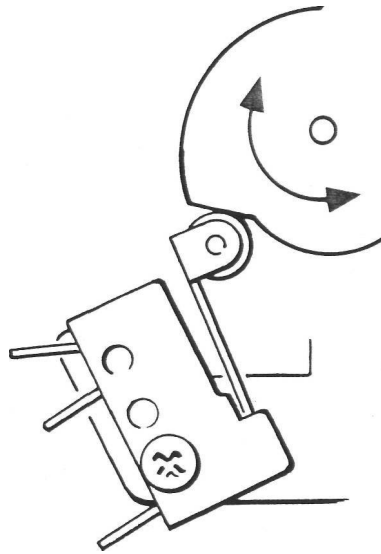

Adjusting the microswitch

Maintenance

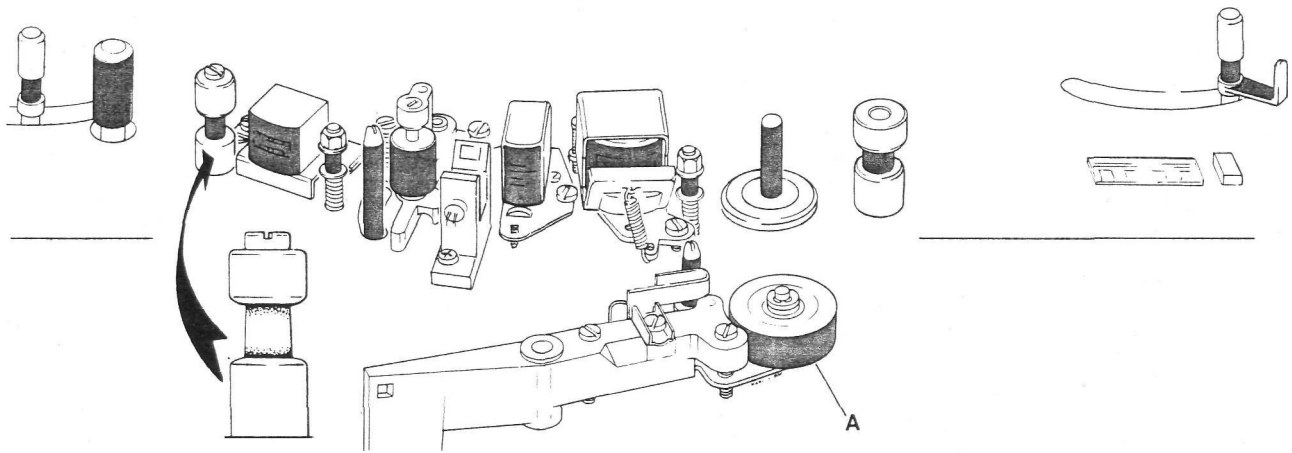

Clean the spots indicated in colour

Cleaning the tape path

It is important that the tape path is clean before adjustments are made. The tape tension arm must also be cleaned. If the heads or guide posts have been adjusted, the tape path must be de-magnetized.

The cleaning can be done with cottonwool or a piece of flannel wrapped around a small stick and moistened with pure alcohol, Freon or methylated spirit (Fire risk!).

Aerosol sprays intended for video tape recorders may be used, but it is not sufficient just to spray the parts, cotton-bud sticks must also be used.

Obstinate deposits on guide posts should be first well softened and then removed with the aid of a toothpick.

The pinch roller A should be cleaned if the tape runs unevenly or if there are visible deposits on the roller. Make sure that the pinch roller is dry after cleaning.



Degaussing

A marked increase in background noise from the tape may indicate that the heads or other parts in the tape path should have the residual magnetism removed (degaussing).

If required, degaussing should be carried out as follows: Switch off the tape deck. Remove the two head covers and move the degausser slowly past each one of the metal parts normally in contact with the tape. Take great care not to let the degausser touch the heads or metal parts in the tape path. Do not switch off the degausser until it is at least 3 ft from the tape deck. Alternatively, follow the degausser maker's instructions.

Lubrication

The pinch roller and the flywheel have self-lubricating bearings and must not be lubricated.

Capstan motor

The bearings on the capstan motor should be lubricated after every 2000 hours of operation. Apply only one drop of Mobil DTE OIL light in each bearing. The oil can be obtained from our service department.

The reel motors

The motors need no lubrication and must not be lubricated.

Tape path adjustments and head alignment

Adjusting the tape path

The heads and the tape guide posts are mounted on a 5 mm aluminium plate. This provides a stable tape path. The bearings for the flywheel is securely fixed to the tape path plate without any adjustment to the capstan. If the tape path plate has to be loosened, it can be replaced without adjustment to the tape path. Under normal use the tape path does not require adjustment.

The tape path must be thoroughly cleaned before adjustments are carried out. Use tape without any defects. If the heads have grooves caused by wear, adjustment of the heads should be avoided.

After replacement of a single part in the tape path, it may often be necessary to adjust the new part only. If, however, more parts have to be adjusted, a complete check and adjustment of the entire tape path must be performed. Adjustments must be carried out in the same sequence as explained in this section.

When the tape deck is in the Stop mode or the mains is switched off, do not press the pinch roller against the heads.

Seal all screws in the tape path after adjustments have been made.

Use tape without any defects.

Adjusting the parallelism

Of all the head adjustments, the parallelism adjustment has any effect on the tape guidance system. Check, and if necessary, adjust the parallelism for the playback head, the record head, the erase head, and the flutter roller. The parallelism alignment is referred to the capstan. A special tool is available.

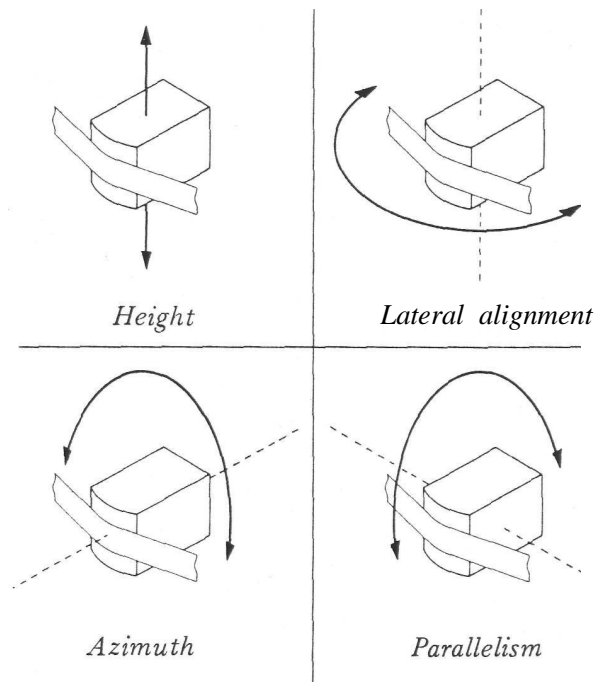

Adjust forwards

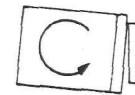

Adjust backwards

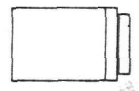

Correct parallelism

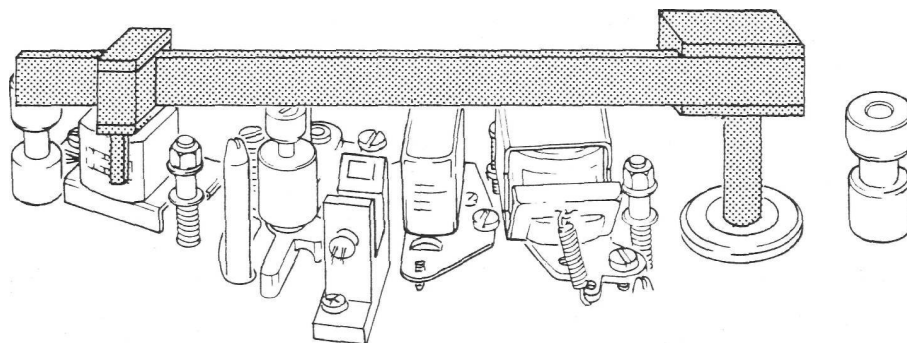

Adjusting the parallelism, with the head tool

Left tape tension arm

When the parallelism is being checked, the left tape tension arm should be adjusted.

The left tape tension arm must be parallel with the fixed tape guide posts, as far as possible. See the figure.

Adjust the height so that the tape (in Play mode) lies up against the top flange of the left fixed tape guide post. The tape should just touch the flange without curling. If necessary, adjust the height by means of screw A. See figure.

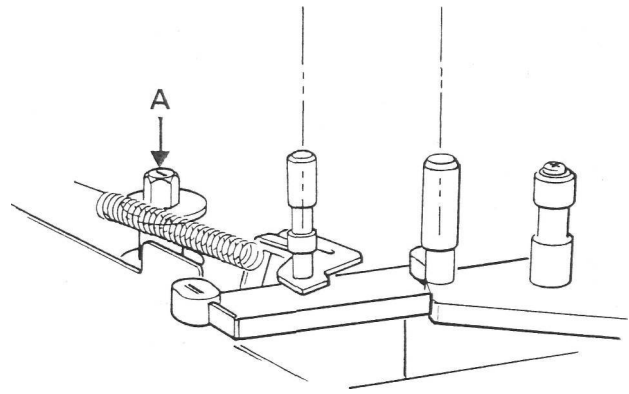

Height adjusting of left tape tension arm

Tape guide posts

When the tape deck is in the Stop mode or the mains is switched off, do not press the pinch roller arm against the heads.

Thread a tape through the tape path. Set the tape deck in the Play mode. Press the pinch roller arm as shown in the figure so that the tape is lifted away from the heads. Allow the pinch roller arm to go slowly back to the Play position and check the height of the adjustable tape guide posts B. When the tape is laid into the tape guide posts, it should touch the top flange of the posts, but it should not be curled in any way.

Press the pinch roller arm several times and check the height of the guide posts, and if necessary adjust them. When the tape guide posts have been adjusted, check the height of the left tape tension arm.

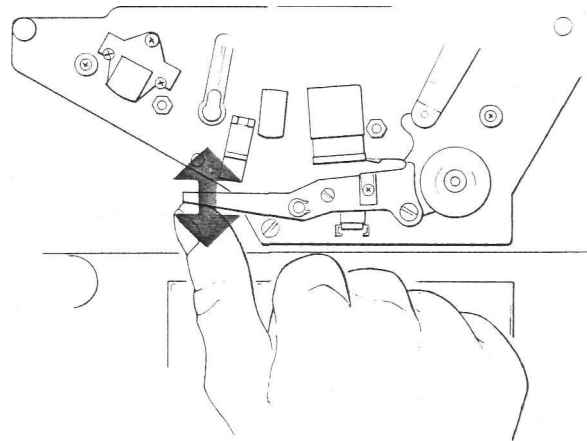

Checking the tape guide posts in Play mode

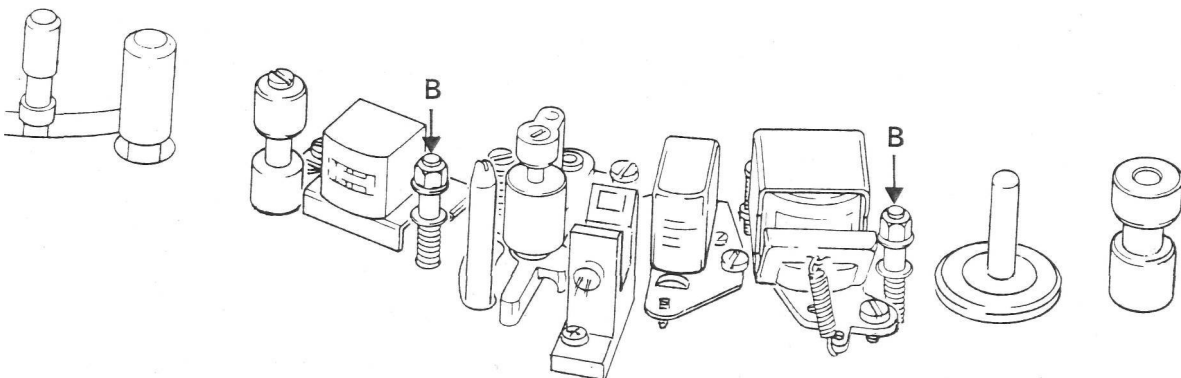

Adjustable tape guide posts

Pinch roller

The two adjustments possible on the pinch roller are parallelism and azimuth.

Parallelism adjustment

Insert a piece of paper into the photo-electric end stop.

Put the tape deck into the Play mode and press the pinch roller arm in the same way as when the height of the tape guide posts was checked. When the pinch roller touches the capstan it shall be parallel. If necessary, adjust screw A. See the figure.

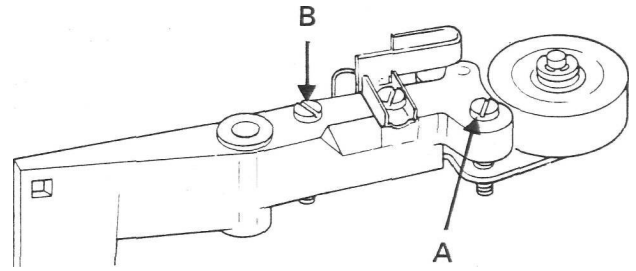

Azimuth adjustment

This adjustment is performed when the tape deck is loaded with tape and the tape deck is in Play mode. Brake the supply reel lightly (by hand) and check that the tape does not move up or down on the capstan or in the tape guides.

If necessary, adjust with screw B. Seal the screw with laquer.

The pinch roller adjustments

Checking and re-adjusting the flutter roller

After each attempt to adjust the flutter roller, stop the tape with the Stop button. Then re-start the tape with the Play button.

Parallelism adjustment

Use the head tool to check the parallelism and if necessary adjust screw A with the Allen key.

If a special tool for checking the parallelism is not available, insert a tape in the tape path. Set the tape deck to Play mode. Adjust screw A until the tape does not bulge on either side of the roller.

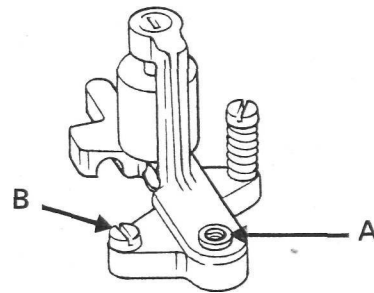

The flutter roller adjustment (seen from the rear)

Azimuth adjustment

Insert a tape and set the tape speed control to 7½ ips. Adjust screw B with a screwdriver to obtain a very slight tilt of the roller (1° to 2°) towards the left. Set the tape deck to Play mode and adjust as follows:

Adjust the roller to the left by means of screw B until it can be clearly seen that the tape touches the upper flange on the tape guide nearest the roller. Then move the roller slightly towards the

right, until the tape barely touches the upper flange of the same tape guide. When properly adjusted, the tape will now move away from the lower flange and barely touch the upper flange.

To make checking easier, place an electric lamp above and behind the tape path and look from the front against the lower flange on the tape guide.

Head alignment with Tandberg test tapes, four track

Playback head

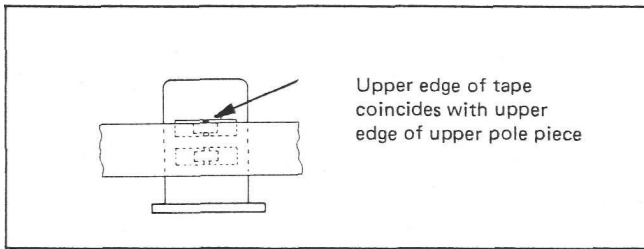

Four track playback head

Record head

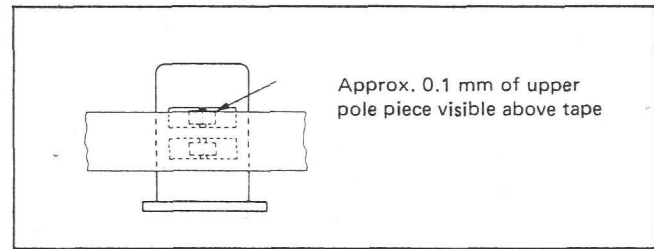

Four track record head

Connect an a.c. voltmeter to each of the LINE OUT sockets and set the Monitor switch to Tape.

Height adjustments

Play back test tape No. 1. This is a full track pre-recorded tape with 1000 Hz recorded at $7\frac{1}{2}$ ips and with the area corresponding to track 3 reduced by approximately 35 dB. Adjust the height of the playback head by means of screw S, see figure on page 19 until minimum output is obtained from track 3, channel R while maintaining the head-front parallel to the tape.

Azimuth adjustments

Play back Tandberg test tape No. 2 at $7\frac{1}{2}$ ips (or a standard azimuth tape). Adjust the azimuth position of the playback head by means of screw B, see figure on page 19, until maximum output on the voltmeters is obtained on both channels, or adjust for the best compromise.

Height adjustment by visual inspection

Insert a new tape and set the deck to Play mode. Check visually that the tape appears to run parallel with the upper track on the record head, within approximately 0.1 mm (0.04") see figure on page 19. If necessary adjust the height with screws C, see figure on page 19, while maintaining the head-front parallel with the tape.

Height adjustment by track measurement

Record in stereo a 1000 Hz signal well above the normal level, first in one direction, then in the opposite direction. Cut off a length of tape and dip into a solution of fine-grained iron-oxide powder and alcohol (Magna See). The tracks will then be visible as four dark stripes.

The figure on page 19 shows the correct pattern on the tape and the patterns obtained when the head is either too high or too low. If necessary, adjust the height of the head and repeat the measurement until the patterns are correct, while maintaining the head-front parallel to the tape.

Azimuth adjustment

Load the tape recorder with a new tape and record at $3\frac{3}{4}$ ips a 18 kHz signal 30 dB below normal recording level in stereo. Set the Monitor switch to Tape. Adjust both Input Level controls for approximately 150 mV reading on a.c. voltmeters connected to the LINE OUT. Adjust the screw D for maximum output from both channels, or the best compromise.



Erase head

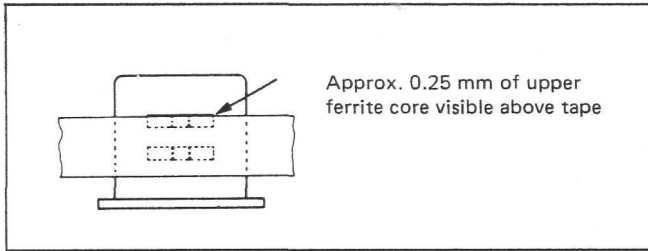

Four track erase head

Height adjustment

By visual inspection, check that approximately 0.25 mm (0.01") of the upper half of the erase head is visible above the tape, see figure.

Insert Tandberg test tape No. 9 and record on channel R a 400 Hz signal well above normal recording level. Dip the tape in a solution of fine-grained iron-oxide powder and alcohol (Magna See). Check that the recorded track is positioned in the centre of the erased track, see correct pattern on page 19. If necessary adjust the height with screws E, see figure on page 19, while maintaining the head-front parallel with the tape.

Head alignment without Tandberg test tapes, four track

Playback head

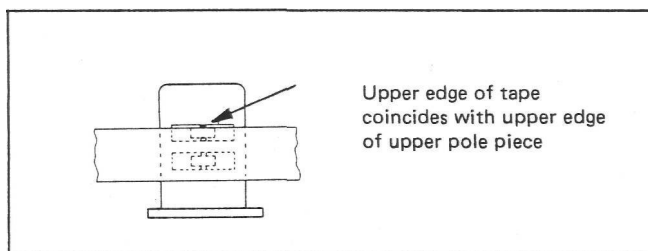

Four track playback head

Height adjustment

Adjust the height of the playback head by means of the screws A, figure on page 19. The upper edge of the tape shall run flush with the upper part of the head lamination for channel L. See figure.

Azimuth adjustment

Set the Monitor switch to Tape. Play back a standard azimuth alignment tape with an a.c. voltmeter connected to LINE OUT. Adjust the position of the playback head by the azimuth adjustment screw B, until a maximum reading is obtained on the voltmeters.

Record head

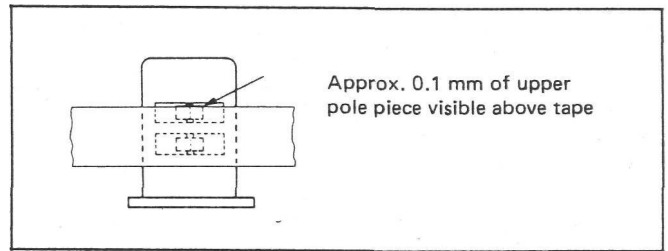

Four track record head

Height adjustment by visual inspection

Insert a new tape and set the tape deck to Play mode. Check visually that the tape appears to run parallel with the upper track on the record head, within approximately 0.1 mm (0.04"), see figure. If necessary adjust the height with screws C, see figure on page 19, while maintaining the head-front parallel with the tape.

Azimuth adjustment

Load the tape deck with a new tape and record at 3% ips a 18 kHz signal 30 dB below normal recording level in stereo. Set the Monitor switch to Tape. Adjust both Input Level controls for approximately 150 mV reading on a.c. voltmeters connected to the LINE OUT. Adjust the screw D, see figure on page 19, for maximum output from both channels, or the best compromise.

Erase head

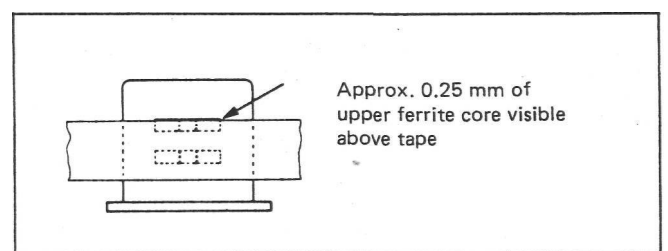

Four track erase head

Height adjustment

Adjust the height of the erase head by means of the screw E, see figure on page 19.

Approximately 0.25 mm (0.01") of the ferrite core for the upper track of the erase head should be visible above the tape, see figure.

Head alignment, two track

Playback head

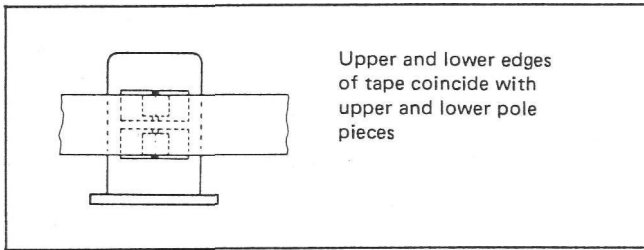

Two track playback head

Height adjustment

Adjust the height of the playback head by means of the screws A, see figure on page 19. The tape shall run parallel with the upper and lower edges of the laminations of the playback head, see figure. If necessary, re-adjust while maintaining the head-front parallel with the tape and check the azimuth position.

Erase head

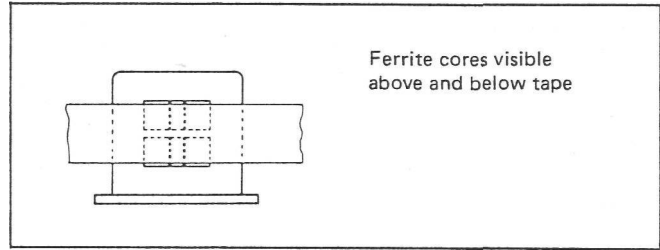

Two track erase head

Height adjustment

Adjust the height of the erase head by means of the screw E, see figure on page 19. Adjust until equal parts of the ferrite cores are visible above and below the tape, see figure. If necessary, re-adjust while maintaining the head-front parallel with the tape and check the height.

Record head

Height adjustment

Adjust the height of the record head by means of the screws C, see figure on page 19.

Record on channel L a 1000 Hz signal at $7\frac{1}{2}$ ips well above normal recording level, first in one direction, then in the opposite direction. Cut off a length of the recorded tape and dip it into a solution of fine-grained iron-oxide powder and alcohol (Magna See). Check that the tracks are distributed symmetrically across the tape. See correct parallelism on page 19. If necessary, re-adjust while maintaining the head-front parallel with the tape and check the azimuth position.

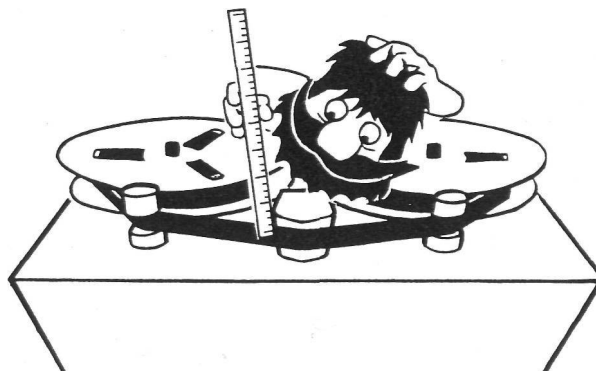

Record and playback curves, NAB

NOTE! 2 track, 7½"/15" speed version only.

This modification is necessary to change from IEC to NAB record and playback equalization.

Remove the wooden cabinet.

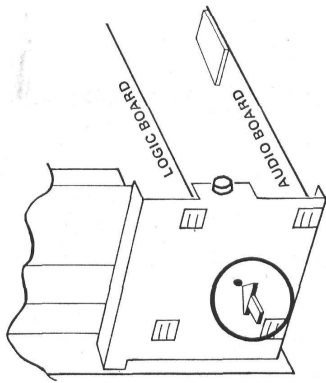

Where to make the hole

Make a hole in the right side panel, approximately 4 mm (3/16"), and fasten the board.

The letters P O S R are printed on the component side of the audio board from approx. serial No.

TEL 295 - 03000

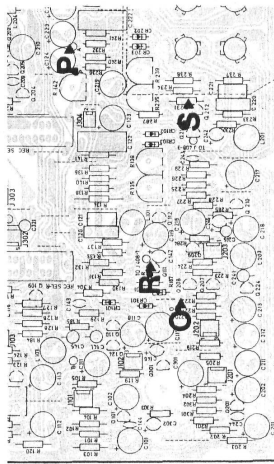

Part of the Audio board, seen from the component side

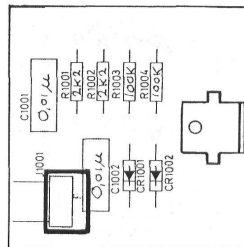

Solder the four wires from the connectors S R P O to their respective terminals S R P O on the Audio board.

NAB Equal Rec. board, seen from the component side

Location of the head alignment screws

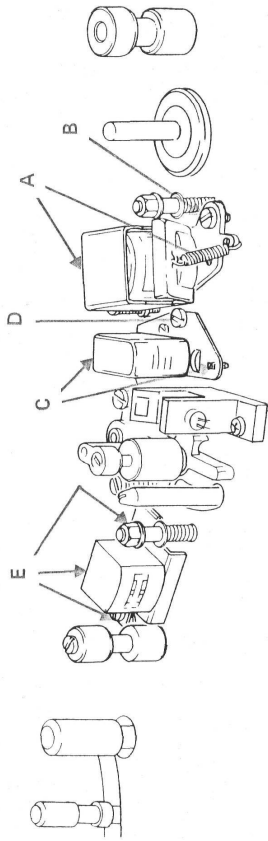

The head adjustment screws

Change and remove the components on the Play/b. amp. board, as shown in the figure.

Remove CR502 and CR602.

Replace CR501 and CR601 with a resistor approx. 50 - 60 ohms.

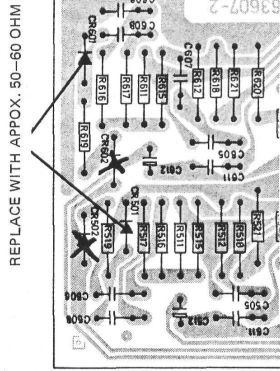

Part of the Equal. Play. amp. board, seen from the solder side

Modification shown on the left channel in the circuit diagram:

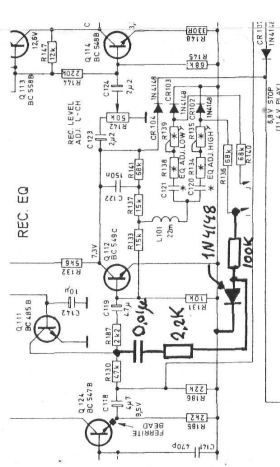

REC. EQ. AMP.

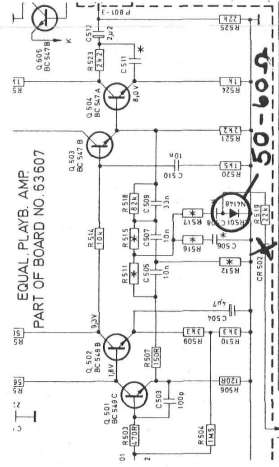

EQUAL. PLAYB. AMP.

TOO HIGH



TOO LOW



CORRECT



Track measurement, four track record head

TOO HIGH



TOO LOW



CORRECT



Track measurement, four track erase head

TOO HIGH



TOO LOW



CORRECT



Track measurement, two track record head

Checking the record and playback curves, IEC

Record curves

The program-meters on the tape deck will give a good indication of how the correction is. As the record correction curves are adjusted to match the corresponding head half, a different reading on the meters within the limits of curve X is normal.

Connect a 100 ohms resistor in series with the record head and ground, as shown in the figure. Connect an audio generator to one of the LINE INPUT sockets and an a.c. millivoltmeter across the 100 ohms resistor.

Set the tape deck in the Stop mode and the Rec. Select switches to On.

Set the record level to — 30 dB on the meters 30 dB below normal recording level. This 30 dB attenuation should be obtained as follows:

10 dB with the Input Level controls on the tape deck and 20 dB with the output control on the audio generator.

Tune the audio generator to 1 kHz and use this for the reference level on the a.c. millivoltmeter (0 dB). Sweep the audio generator over the frequency range and check that the readings on the a.c. millivoltmeter correspond to the curves shown in the figures.

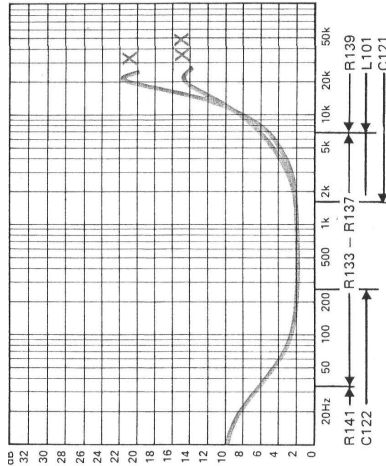

X R139 and R239 to maximum
XX Typical record curve

Record correction curve 3% ips

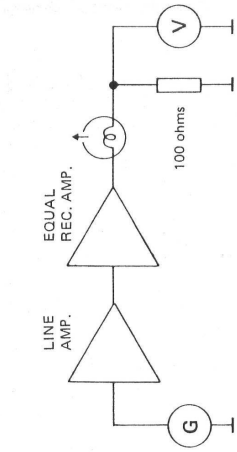

Checking the record curve

Playback curve IEC

Connect a 10 Kohms resistor in series with the playback head and a 10 ohms resistor to ground, see figure.

Set the tape deck in Stop mode, the Monitor switch to Tape and the Edit/Cue switch to On.

Connect the audio generator to the matching network as shown in the figure. Connect an a.c. millivoltmeter to the LINE OUT socket. Tune the audio generator to 1 kHz and adjust the signal level to 75 mV measured in the LINE OUT socket. Then check that shape of the playback curve corresponds to the curve shown in the figures.

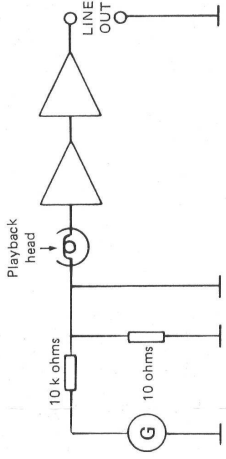

Checking the playback curve

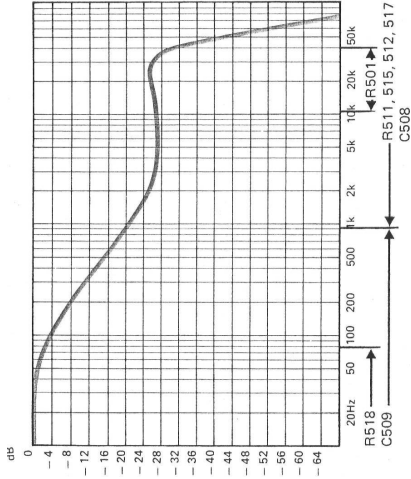

Playback correction curve 3 3/4 ips

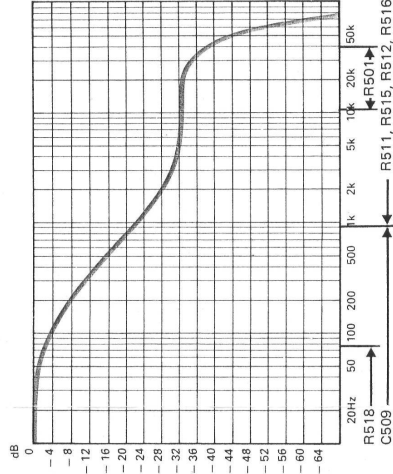

Playback correction curve 7 1/2 ips

Record correction curve 7 1/2 ips

Fault in the total response curve, one channel

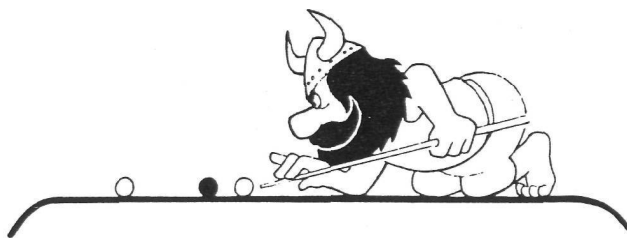
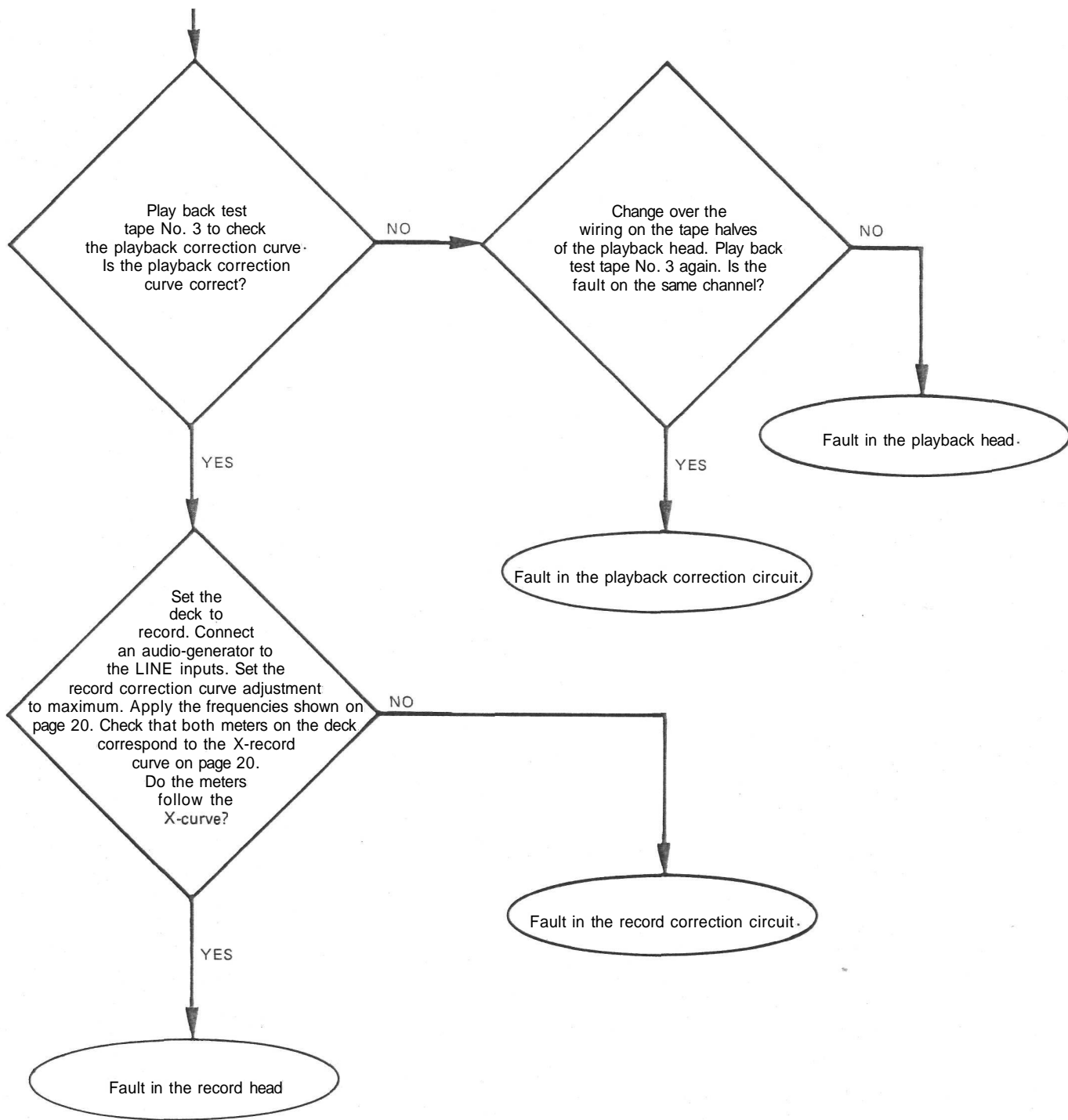

38 kHz filter in record amplifiers

Unwanted modulations (whistles) can be set up when an FM stereo program is being recorded. These are caused by poor filtering of the FM pilot tone in the receiver (38 kHz).

Solder in two 1.5 μF capacitors (C145/C245) in the record amplifiers. Coupled with L103/L203 the capacitors form a 38 kHz filter. The 38 kHz signal is now reduced by about 35 dB when FM stereo signals are received.

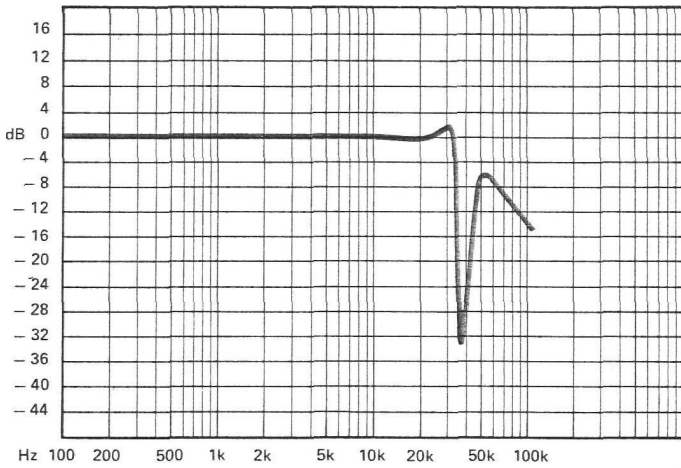

38 kHz trap curve

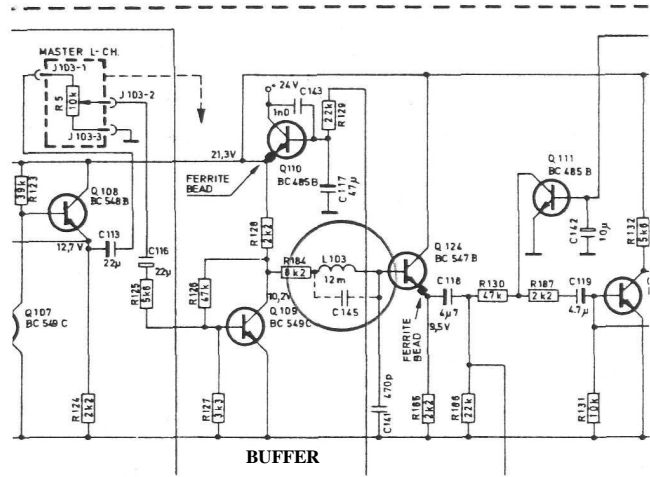

38 kHz trap in the record amplifier

EOT/BOT sensor (end of tape/beginning of tape)

The sensor is located in the tape path. The circuit gives a logic high (1) or logic low (0) dependent on whether there is tape in the tape path.

- Tape in the tape path, the circuit goes high (1).
- No tape in the path, the circuit goes low (0).

The adjustment of EOT/BOT sensor should be performed without tape. Measure with a d.c. voltmeter on pin 3, contact 412 on the logic board. Adjust R422 (on the logic board) to 1.2 V reading on the voltmeter.

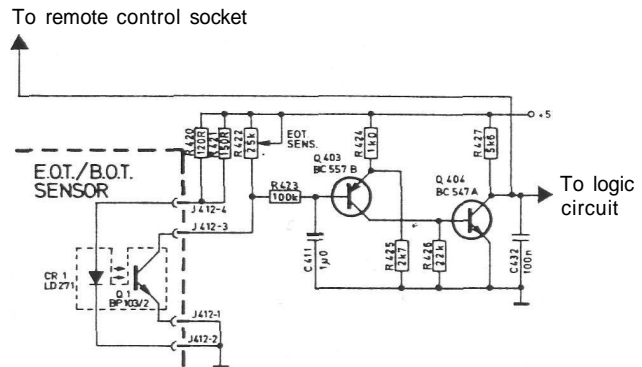

EOT/BOT (end of tape/beginning of tape) sensor which is a part of the Logic circuit

Power On/Off circuit

The circuit provides:

- Time delayed muting — current/voltage to the audio section to cut out unwanted signals in the audio output when the mains is switched on/off.
- Regardless of the position to the worm-gear when the current is switched off or interrupted, or when the mains voltage drops by more than 25%, the circuit will generate signals for turning the worm-gear motor to (or nearly to) the Stop position and the C423 (3300u) retain enough energy to turn the motor.

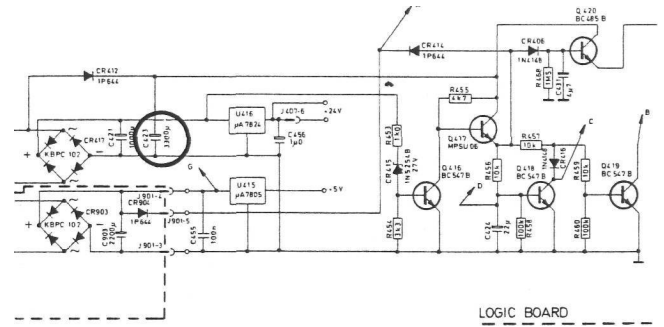

Power On/Off circuit which is a part of the Logic circuit

TMI sensor (tape motion indicator)

The sensor is located under the right turntable which is fitted with a ring of teeth. The circuit determines the timing of the braking phase.

The circuit generates a logic high (1) or logic low (0) dependent on whether the tape stands still or moves:

- Tape stands still gives 1.
- Tape moves gives 0.

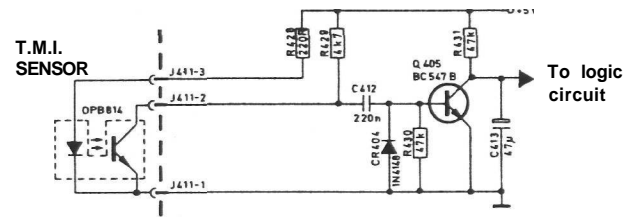

TMI sensor (tape motion indicator) which is a part of the Logic circuit

Control circuit for reel motors

This circuit controls the a.c. or d.c. voltage to the required motor.

The motors are driven by a.c., and d.c. is used for the brakes.

The circuit is controlled by logic signals from U3 (a PROM which is a control and memory unit).

A TRIAC is a semiconductor device which in this application controls d.c. or a.c. in OFF/ON modes. The TRIAC is open for a.c. when the gate is forced low relative to the reference voltage of 5 V in the TRIAC-circuit.

The circuit gives the following combinations of voltages to the reel motors:

Q410:	100 V	a.c. TRIAC
Q411:	60 V	a.c. TRIAC
Q412:		d.c. rewind motor TRIAC
Q413:		a.c. rewind motor TRIAC
Q414:		d.c. wind motor TRIAC
Q415:		a.c. wind motor TRIAC

Transistors used in the TRIAC-circuit

Function	From PROM (U3)				Shinano Kenshi IB 963 (Grey motors)		Pabst RO. 2080 (Black motors)	
	Z2	Z2	Z3	Z4	RW-motor J415-6	W-motor J415-7	RW-motor J415-6	W-motor J415-7
Stop/Free	*	*	1	1	approx. 9 V d.c.	approx. 9 V d.c.	approx. 5 V d.c.	approx. 5 V d.c.
Play/Record	1	0	1	0	approx. 9 V d.c.	60 V a.c.	approx. 5 V d.c.	60 V a.c.
Wind	0	1	1	0	approx. 9 V d.c.	100 Va.c.	approx. 5 V d.c.	approx. 105 V a.c.
Rewind	0	1	0	1	100 Va.c.	approx. 9 V d.c.	approx. 105 V a.c.	approx. 5 V d.c.
Wind and Rewind simultaneously	0	1	0	0	100 Va.c.	100 Va.c.	100 Va.c.	100 Va.c.

Don't care.

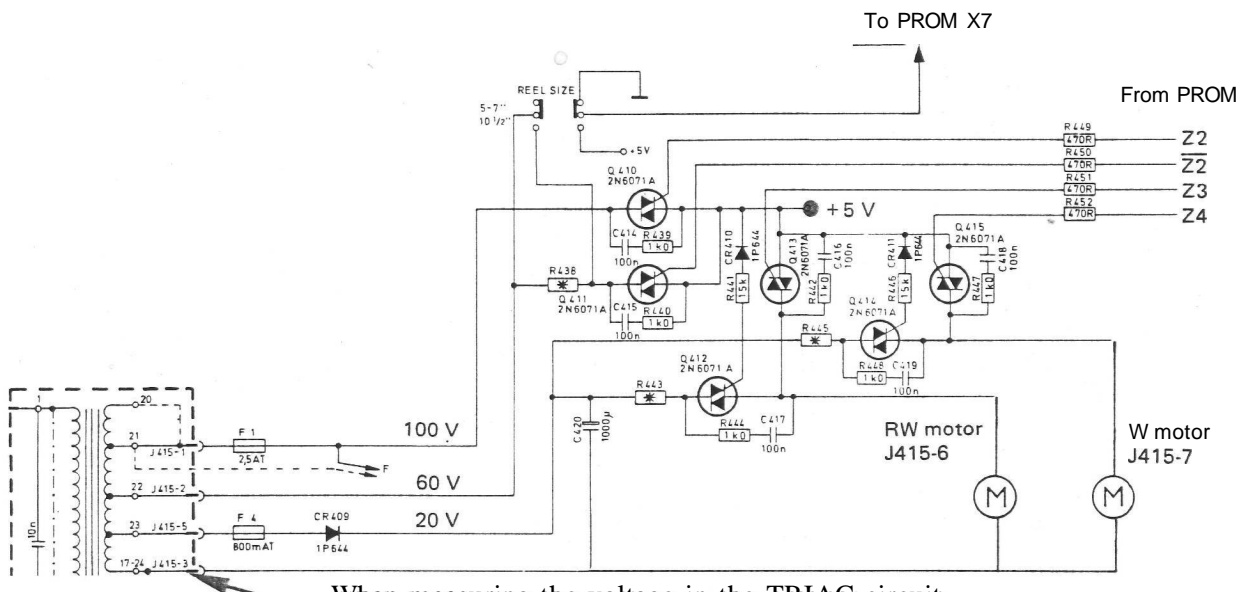

When measuring the voltage in the TRIAC-circuit, the voltmeters — side must be connected to point J415-3.

Worm-gear motor

The worm-gear motor drives the worm-gear wheel which has three functions:

1. Holds the transfer arm for the pinch roller ready. The transfer arm also connects and disconnects the mechanical servo brakes.
2. Timing sequence which determines when the brakes are operated.
3. Timing sequence for microswitches X0 and X1 which give status to the PROM about the tape deck's functions.

The worm-gear wheel has three stop positions. The stop positions are chosen to work with the switching points on microswitches X0 and X1 so that the output level from the switches changes from 0 to 1 or vice versa.

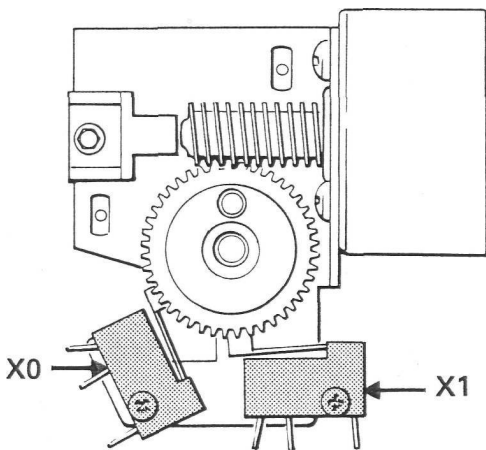

Placing of the microswitches X0 and X1

There are three stable stop positions:

- Stop: Outputs from X0 and X1 are low.
- Free/Wind and Rewind: X0 is high and X1 is low.
- Record/Play: X0 is low and X1 is high.

The mechanical settings of the switching points on X0 and X1 are critical, see mechanical adjustments on page 11.

The worm-gear motor is controlled by the following signal levels from U3 (PROM):

From PROM		Motor
Z0	Z1	
0	0	No rotation
0	1	Rotates in one direction
1	0	Rotates in the opposite direction

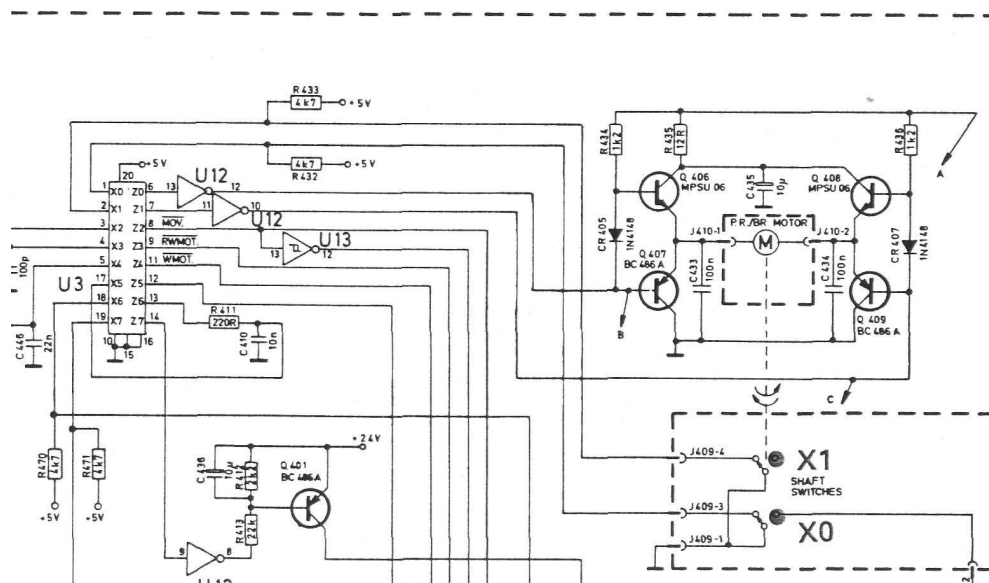

Control circuit for the worm-gear motor

Logic Circuits

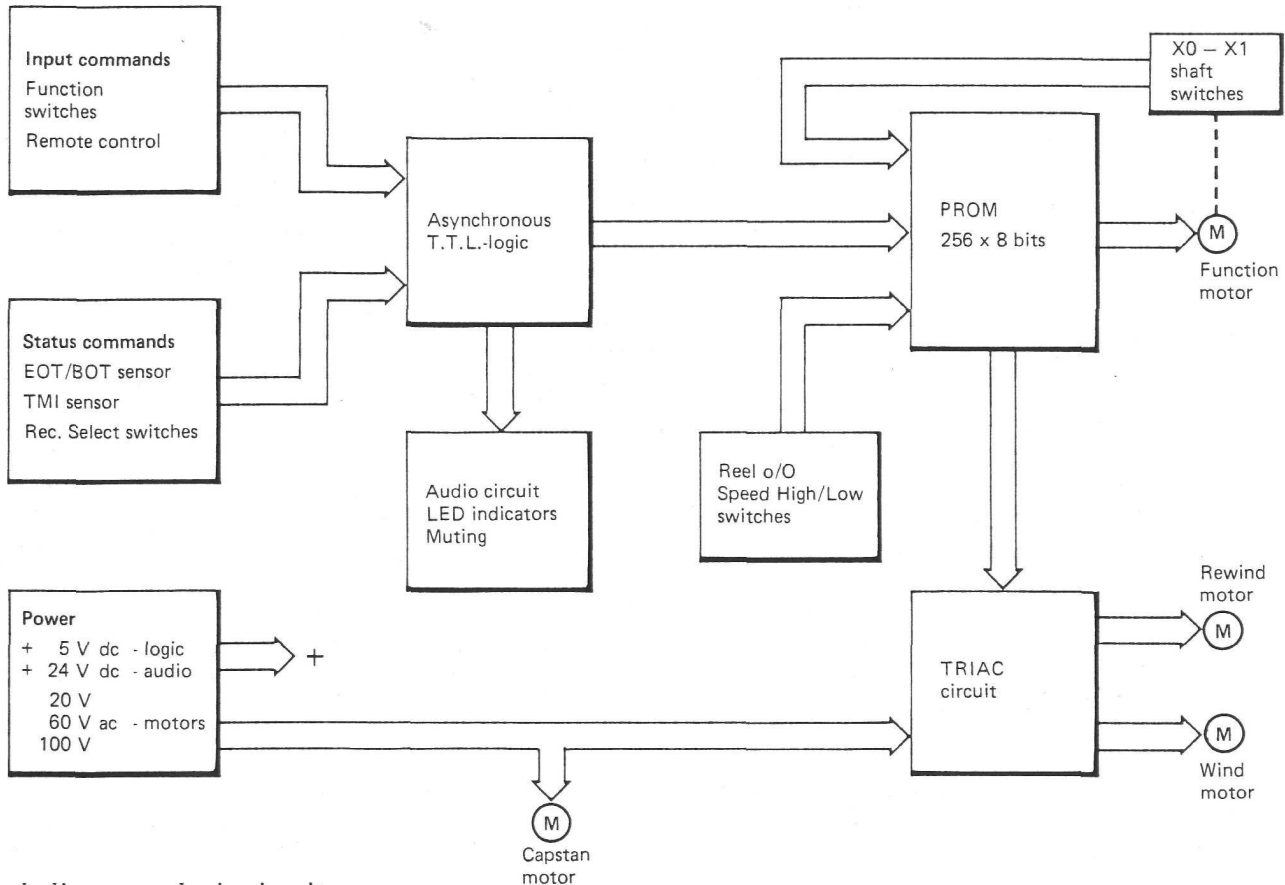

Block diagram – logic circuits

U1 and U2 Circuits

U1 is an encoder and U2 is a decoder.

The inputs to U1 are command lines which are controlled by the function buttons. The letter C (command) is written after the function name on the inputs to signify that it is a command line. When the function lines have a bar over the top e.g. \overline{XC} the function is activated at a low level (0).

U1 sets up a particular bit pattern at the outputs A0, A1, and A2 for a particular required function.

The bit patterns at A0, A1, and A2 are applied to inputs A, B, and C on the decoder U2. U2 is activated and sends the output for the required function low (0). The letter O after a name on a function line means that it is an output.

OUTPUT U1

Command	A2	A1	A0
Free	0	0	0
W/Rw	0	0	1
Wind	0	1	0
Rewind	0	1	1
Play	1	0	0
Record	1	0	1
	1	1	0
Stop	1	1	1

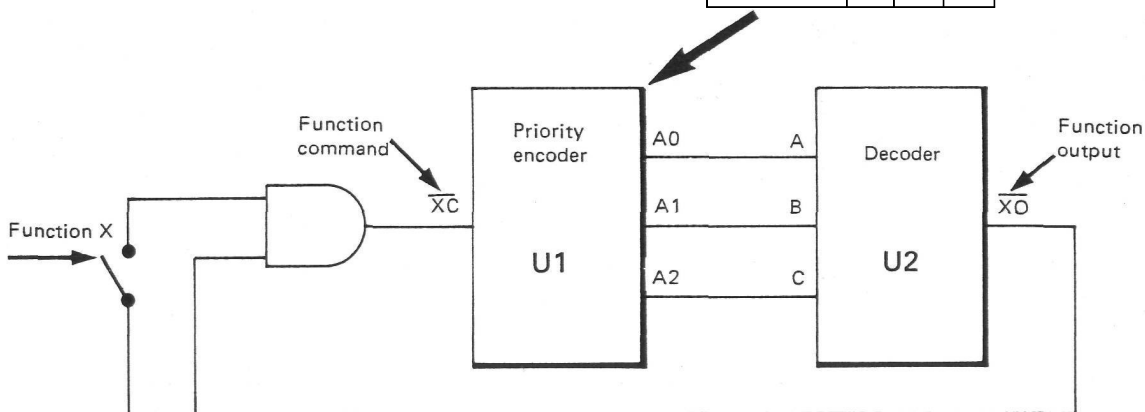

The "memory" function

The a-synchronous logic circuit

This circuit consists of components U1 to U14, apart from U3 which is a PROM.

The purpose of the circuit is to generate logic signals according to a particular bit pattern for U3 (PROM), the audio circuits, and the LED function indicators.

The circuit operates at either a high level or a low level:

Low level (0) is between 0 and 0.8 V.

High level (1) is between 3.5 and 5 v.

This is carried out with the aid of:

- Function buttons Record, Rewind, Stop, Wind, and Play.
- Rec. Select selector Left and Right.
- The EOT/BOT sensor (end of tape/beginning of tape).
- The TMI sensor (tape motion indicator).

The PROM control unit

The command signals from the a-synchronous logic circuit to the PROM are generated according to the function which is required, as shown in the table.

INPUT U3			
Command	X4	X3	X3
Free	0	0	0
Wind/Rewind	0	0	1
Wind	0	1	0
Rewind	0	1	1
Play/Record	1	0	0
Stop from Wind	1	0	1
Stop from Rewind	1	1	0
Stop (EOT)	1	1	1

The circuit gives:

- Control signal to BIAS/ERASE OSC: 24 V d.c. (assumes BOT) in Record 0 V for all other functions.
- Control signal for programmed switching: 0 for Play 1 for all other functions.
- Control signal for muting of REC.AMP: 0 for Record and Stop 1 for Play, Wind, Rewind, and Free.
- Control signal for the LED (light emitting diode) which indicates the functions.
- Command signals to the inputs X2, X3, and X4 on the PROM, see table:

The control unit is a PROM (Programmable Read Only Memory) which is a memory device that can be programmed. U3 (the PROM) has a capacity for 256 x 8 bits, which means that it has a total of 8 inputs ($2^8 = 256$ combination possibilities of input signals) and 8 outputs.

In addition to its role in the digital servo system, U3 also serves other purposes, see figure.

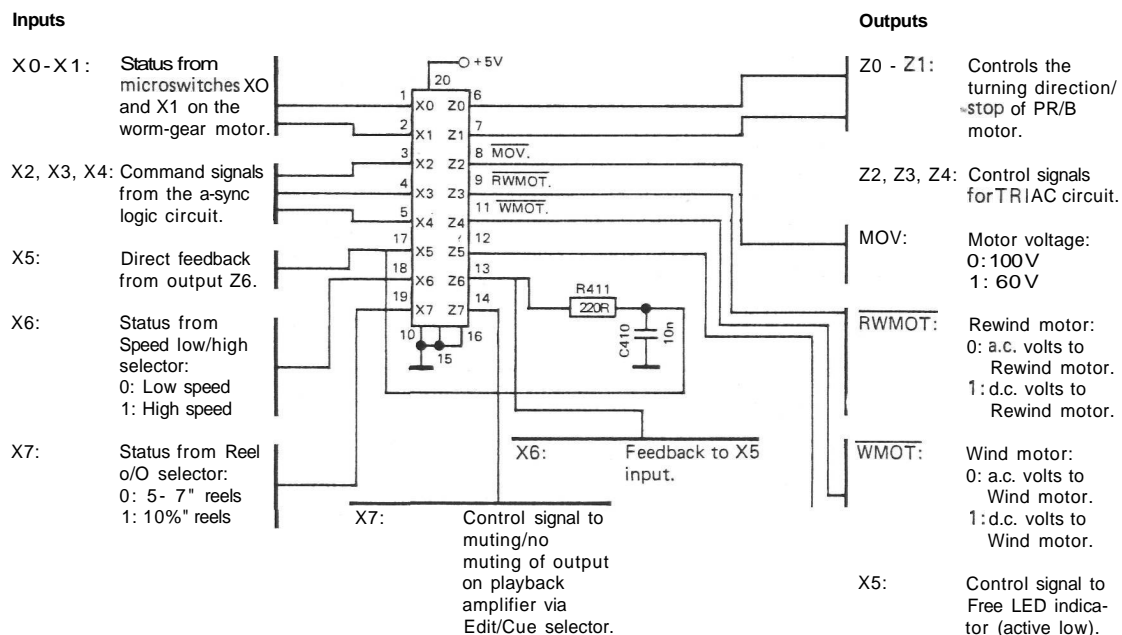

Inputs and Outputs on U3

Electrical adjustments

Make the adjustments in the order in which they are listed here. Many of the adjustments require that previous adjustments have already been correctly made.

Clean and degauss the tape path before and after adjustments. It is assumed that the tape path has already been correctly adjusted as described on page 13.

Maxell UD XL or equivalent tapes should be used for recording.

Necessary equipment

- d.c. voltmeter
- 2 high impedance voltmeters (do NOT use universal meters).
- Frequency counter.
- Audio generator.
- Distortion meter.
- Wow meter (required for wow test only).
- Test tapes:
 - No. 2 — Azimuth adjustment playback head 15,000 Hz, 7½ ips.
 - No. 3 - Playback curve, DIN 19H, 7½ ips.
 - No. 4 — Playback level adjustment, 400 Hz, 7½ ips.
 - No. 11 - Speed check, 1000 Hz, 7½ ips.

Bias Adjustment (front panel)

Before adjustment, make sure that the Bias Adjustment potentiometers on the front panel are in the mid-position.

Checking the oscillator frequency

Connect a frequency counter inductively to the erase head. Connection is made with a coil or a few turns of ordinary wire.

Adjust the frequency to 123.5 kHz in stereo recording with C313 on the logic board. Then check in mono, left and right, that the frequency are within ± 2 kHz. If outside the tolerance, adjust C303, DUMMY LOAD ADJ. on the audio board. Then check the frequency in stereo and mono left and right.

Checking the Bias Adjustment (front panel)

Connect an audio-generator to LINE 1. Start stereo recording at 7½ ips speed of a 22 kHz signal 30 dB below normal recording level (0 dB). Set the Monitor switch to Tape. Check that the output level measured with a.c. voltmeters on the LINE OUT are within approximately + 3 dB to — 5 dB when turning the Bias Adjustment potentiometers.

After checking the Bias Adjustment, make sure that the potentiometers are set in the mid-position for use with Maxell UD XL or equivalent tapes.

Adjustment of EOT/BOT sensor

To be performed without tape. Measure with a d.c. voltmeter on pin 3, contact 412 on the logic board.

Adjust R422 (on the logic board) to 1.2 V reading on the voltmeter.

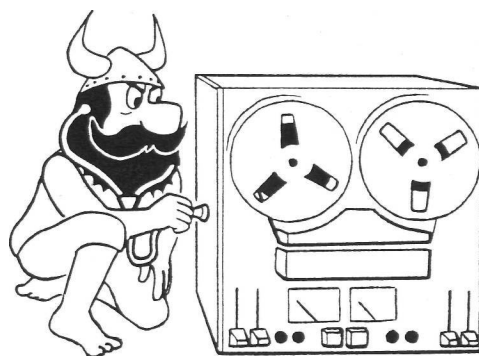

Test No.	Adjustment or check	Test tape No.	Set the deck to	Measuring instrument	Measure at	Adjust	Correct reading	Speed	Comments
1.1	Azimuth, playback head	2	Playback	a.c. voltmeters	LINE OUT	Azimuth screw, playback head	Maximum output, see comments	7 1/2 ips.	Maximum output or best compromise.
1.2	Playback curve DIN 19H	3	Playback	a.c. voltmeters	LINE OUT	Playback E.C. adj. R501/R601	+ 2 dB at 18 kHz	7 1/2 ips.	Playback curve, DIN 19H. The tape contains the following frequencies: 1000 Hz (reference) 18 kHz, 15 kHz, 10 kHz, 4 kHz, 125 Hz, 40 Hz 1000 Hz [REF]. Adjust R501/R601 to + 2 dB at 18 kHz.
1.3	Playback level	4	Playback	a.c. voltmeters	LINE OUT	Playback level R169/R269	1.0 volt	7 1/2 ips.	
1.4	Speed	11*	Playback	Frequency counter	LINE OUT		± 0.5% 995-1005 Hz in 7 1/2 ips.		Test tape No. 11* is recorded at 1000 Hz in 7 1/2 ips.

* Test tape No. 11 is supplied on a small reel. This test tape should be spliced into a tape on a larger reel.

Test No.	Adjustment or check	Measuring instrument	Measure at	Set the deck to	Monitor switch to	Procedure
2.1	Bias pre-adjustment	a.c. voltmeters	LINE OUT	Record. Speed: 3 3/4 ips.	Tape	Connect an audio-generator to LINE 1. Set the generator to 6.3 kHz 30 dB below normal recording level (0 dB). Adjust R151 and R251 to maximum output level. Then turn R151 and R251 counter clockwise to - 2 dB from maximum reading.
2.2	Azimuth record head	a.c. voltmeters	LINE OUT	Record. Speed: 3 3/4 ips.	Tape	Connect an audio-generator to LINE 1. Start stereo recording at 3% speed of a 1000 Hz signal 30 dB below normal recording level (0 dB). Use the voltmeter readings as reference level. Then record a 15,000 Hz signal and turn the azimuth screw on the record head to maximum reading or best compromise on the voltmeters.
2.3	Record/playback curves, 3% ips.	a.c. voltmeters	LINE OUT	Record. Speed: 3 3/4 ips.	Tape	Connect an audio-generator to LINE 1. Start recording in the 3% ips. speed of a 1000 Hz signal 30 dB below normal recording level (0 dB). Use the voltmeter readings as reference level (0 dB). Then turn the generator to 12.5 kHz and adjust R151 and R251 to + 1 dB from the reference level. Turn the generator to 18 kHz and adjust R139 and R239 to - 1 dB below the reference level. Then check that the output level do not deviate more than ± 3 dB from 20 Hz to 18,000 Hz.
2.4	Record/playback curves, 7 1/2 ips.	a.c. voltmeters	LINE OUT	Record. Speed: 7 1/2 ips.	Tape	Use the same recording level as in test 2.3. Use the voltmeter readings as reference level (1000 Hz). Turn the generator to 25 kHz and adjust R135 and R235 to - 1 dB below the reference level. Then check that the output level do not deviate more than ± 3 dB from 20 Hz to 25,000 Hz.
2.5	Source/Tape	a.c. voltmeters	LINE OUT	Record. Speed: 7 1/2 ips.	Source/Tape	Connect an audio-generator 1000 Hz to LINE 1. Adjust the sources with the input levels to 0.6 V on the voltmeter. Set the level on the LINE OUT. Set the level on the Monitor switch to Tape. Then adjust R142 and R242 so that the level reading is 1 dB higher on the voltmeters.
2.6	Program meter adjustment	a.c. voltmeters	LINE OUT	Speed: 7 1/2 ips.	Source	Audio-generator 1000 Hz to LINE 1. Set the Monitor switch to Source. Adjust with the Input Levels to 15 V reading on the voltmeters. Then adjust the program meters to 0 dB with R158 and R258 (Output Left and Right on maximum).
2.7	Distortion	Distortion meter	LINE OUT	Record. Speed: 7 1/2 ips.	Tape	Connect an audio-generator, 1000 Hz (or distortion meter generator) to LINE 1. Record to 0 dB indication on the program meters and read the distortion on the LINE OUT. Distortion maximum 2%.
2.8	Wow and flutter	Wow and flutter meter	LINE OUT	Record.	Tape	Connect the wow and flutter meter to LINE 1. Read on the LINE OUT in highest and lowest speed. Wow and flutter maximum: 3% ips. 7 1/2 ips. 15 ips. Weighted RMS 0.10% 0.05% Peak value DIN 45500 P-A 0.14% 0.08% 0.08%

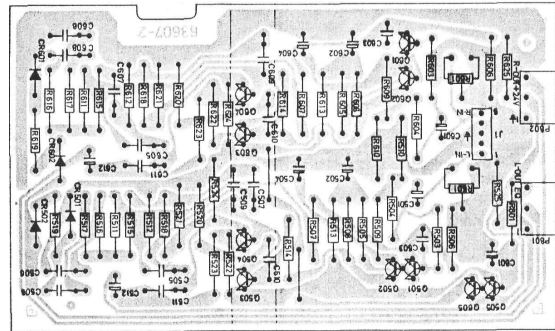

Playback amplifier board (solder side)

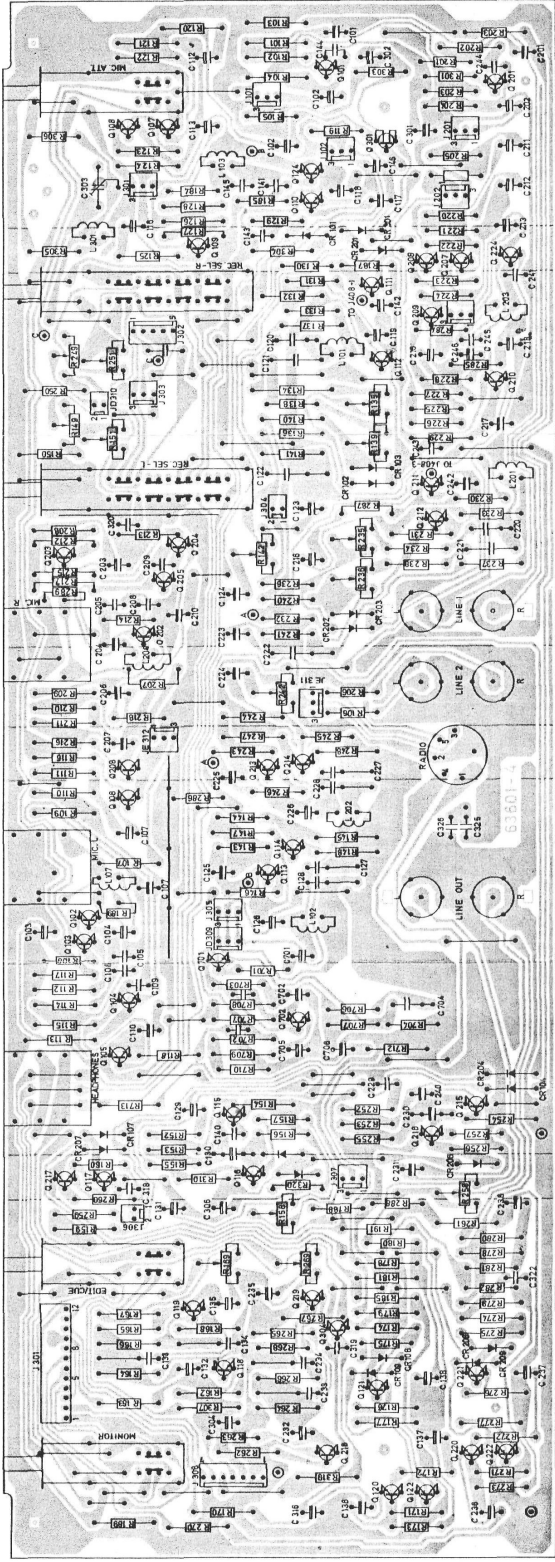

Location of adjustment points on the audio board, solder side

FUNCTION TABLE

INPUTS		OUTPUTS										
E	D0	D1	D2	D3	D4	D5	D6	D7	A2	A1	A0	E0
1	x	x	x	x	x	x	x	1	1	1	1	1
0	1	1	1	1	1	1	1	1	1	1	1	0
0	x	x	x	x	x	x	0	0	0	0	0	1
0	x	x	x	x	0	1	0	0	1	0	1	0
0	x	x	x	0	1	0	1	0	1	0	0	1
0	x	x	x	0	1	0	1	0	1	0	1	0
0	x	x	0	1	1	0	1	0	1	0	1	0
0	x	0	1	1	1	1	0	0	0	1	1	0
0	x	0	1	1	1	1	1	0	1	0	1	0
0	0	1	1	1	1	1	1	1	1	0	0	1
0	0	1	1	1	1	1	1	1	1	1	1	0

U1:
SN74148.

x = don't care
1 = high level
0 = low level

OUTPUT U1

COMMAND	A2	A1	A0
REW	0	0	0
WIND	0	0	1
REWIND	0	1	0
PLAY	1	0	0
RECORD	1	0	1
STOP	1	1	0

FUNCTION TABLE

INPUTS		OUTPUTS										
G1	G2B	C	B	A	Y0	Y1	Y2	Y3	Y4	Y5	Y6	Y7
x	1	x	x	x	1	1	1	1	1	1	1	1
0	x	x	x	x	1	1	1	1	1	1	1	1
1	0	0	0	0	1	1	1	1	1	1	1	1
1	0	0	1	0	1	1	1	1	1	1	1	1
1	0	0	1	0	1	1	1	1	1	1	1	1
1	0	1	0	0	1	1	1	1	1	1	1	1
1	0	1	0	1	1	1	1	1	1	1	1	1
1	0	1	1	0	1	1	1	1	1	1	1	1
1	0	1	1	1	0	1	1	1	1	1	1	1
1	0	1	1	1	1	0	1	1	1	1	1	1
1	0	1	1	1	1	1	0	1	1	1	1	1
1	0	1	1	1	1	1	1	0	1	1	1	1

U2:
SN74LS138

x = don't care
1 = high level
0 = low level

Supplies + 24 V d.c. in Stop, Wind and Rewind to the Edit/Cue switch.

INPUT U3

COMMAND	X1	X3	X2
FREE	0	0	0
W-RW	0	0	1
WIND	0	1	0
PLAY/REC	0	1	0
STOP FROM WIND	1	0	1
STOP FROM REW	1	0	1
STOP (E0)	1	1	1

Control circuit for worm-gear motor. This circuit provides the operating voltage for the worm-gear motor. The circuit receives command signals from U3 (PROM) which determine the turning direction and stop-position of the worm-gear motor.

Microswitches X0 and X1 give status to U3 (PROM) about the position of the worm-gear motor.

LED (light emitting diodes) which indicates the functions.

Supplies + 5 V d.c. in Play, Wind, Rewind, and Free to Q111 and Q211. Supplies + 5 V d.c. to the program meter switches Q117 and Q217.

Supplies + 24 V d.c. to the bias selector in record mode.

Control circuit for reel motors
This circuit controls the a.c. or d.c. voltage to the required reel motor.
The motors are driven by a.c. voltage and d.c. voltage is used for braking.
The circuit is controlled by logic signals from PROM U3 (control and memory device).

Table 2

COMP.	230 V/50 Hz	230 V/50 Hz	115 V/60 Hz	115 V/60 Hz
	7% - 3% ops.	15 - 7% ops.	7% - 3% ops.	15 - 7% ops.
R43B	120R	68R	68R	68R
R443	120R	120R	220R	120R
R445	120R	120R	220R	120R
U3	SN745471	VIOLET	ORANGE	VIOLET
	956122	956122	956123	956123
	MARKED			

Power On/Off circuit. Gives delayed muting-current/voltage to the audio section to suppress unwanted signals at the audio outputs when the mains is switched on/off.
Regardless of the position of the worm-gear motor when the mains is switched off, the mains supply is interrupted, or when the mains voltage drops by more than 25%, the circuit generates signals for turning the worm-gear motor to (or nearly to) the Stop-position, and retains enough energy to carry out this operation.

Tape speed low/high circuit. Gives + 5 V d.c. to record and playback equalization. The circuit gives status to U3 (PROM) about the speed of the capstan motor.

Function buttons which activate the logic circuit with a low (0) level.

EOT/BOT sensor
The sensor is located in the tape path. The circuit outputs logic high (1) or logic low (0) dependent on whether there is tape in the path.
— No tape, circuit outputs low (0).
— Tape in tape path, circuit outputs high (1).

TMI sensor
The sensor is located under the right turntable which has a ring of teeth. This circuit determines the timing of the braking phase.
— Tape moves = 0.
— Tape stands still = 1.

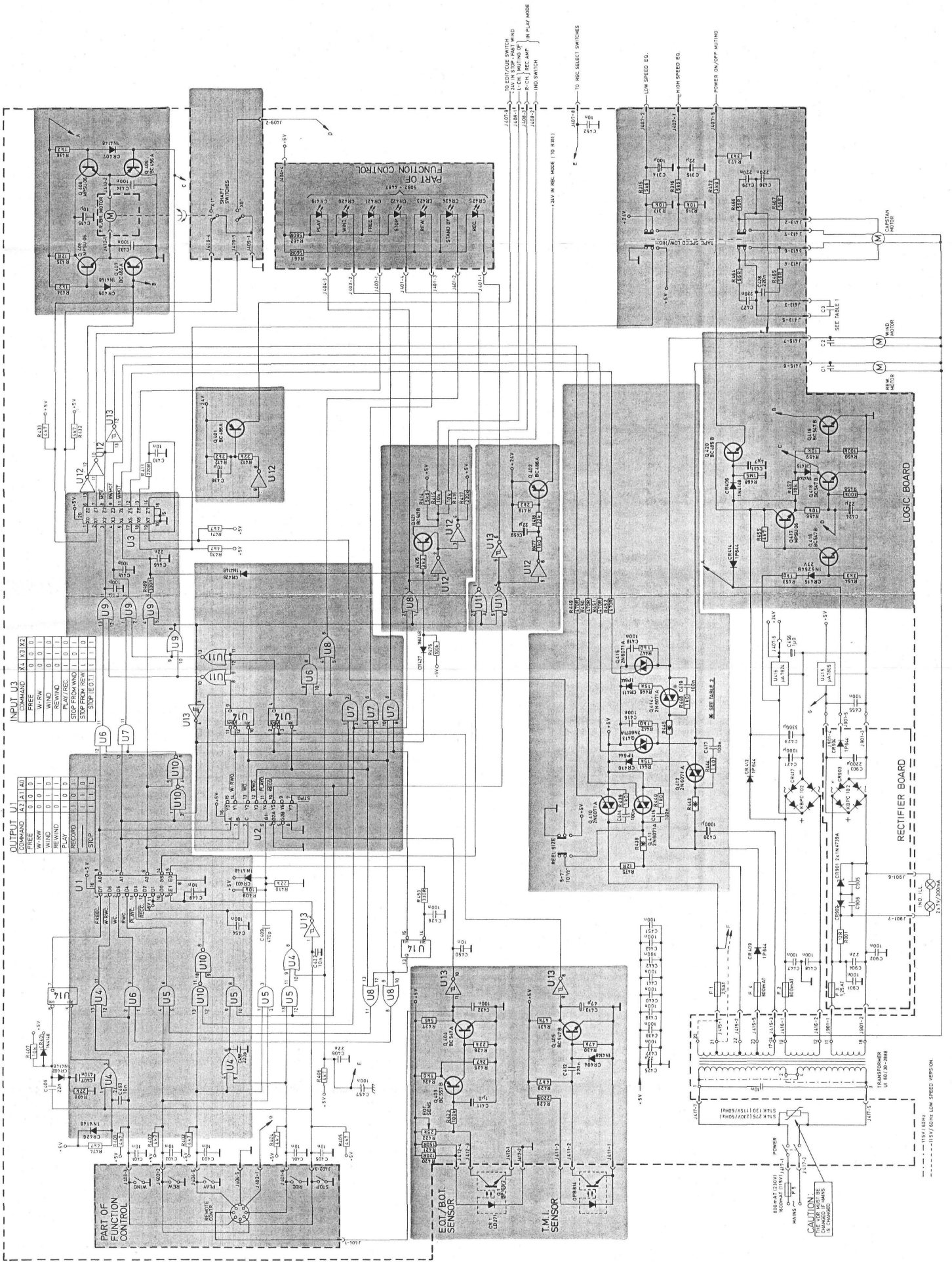

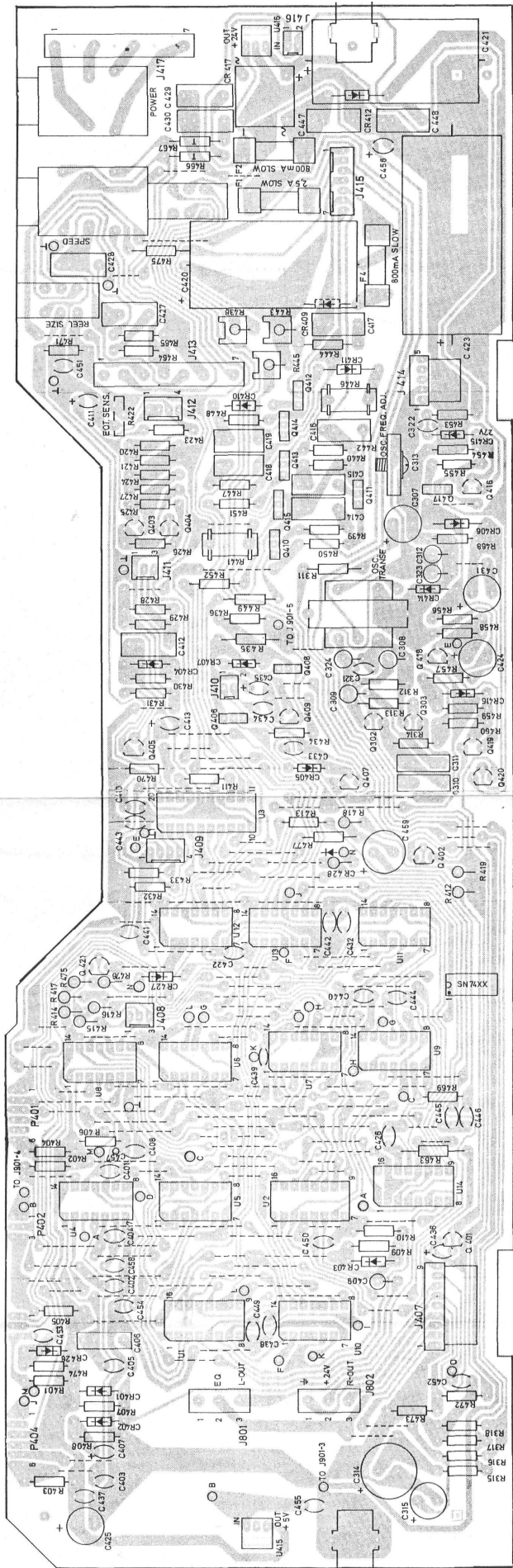

LOGIC BOARD, COMPONENT SIDE

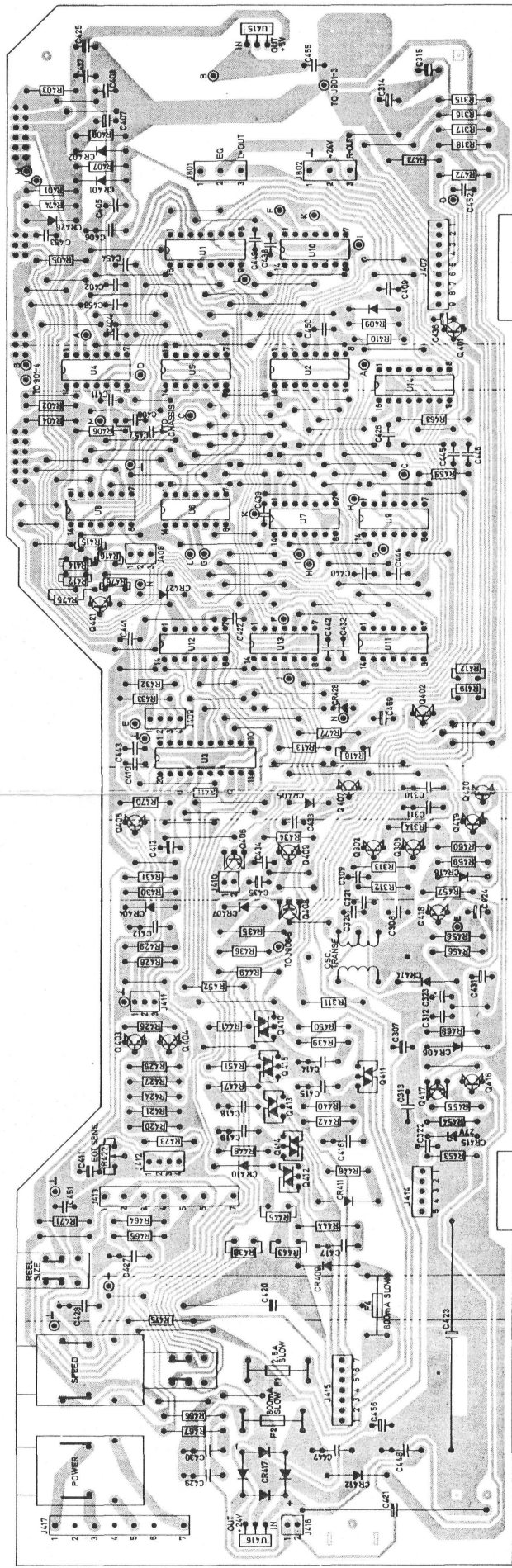

LOGIC BOARD, SOLDER SIDE

TTL circuits used:
Truth table

Description	Symbol	Inputs	Output
AND-gate		A B	C
NAND-gate		A B	C
OR-gate		A B	C
NOR-gate		A B	C
INVERTER		A	C

TABLE 1

COMP	120V / 60Hz	115V / 60Hz
C.1	5J	4A3
C.2	5J	4A3
C.3	3A8	2A8

TABLE 2

COMP	120V / 60Hz	115V / 60Hz
R.208	220R	68R
R.443	220R	220R
R.445	220R	220R
U.3	220R	220R
U.10, U.11, U.12, U.13	220R	220R
U.14	ORANGE	VIOLET
U.15	ORANGE	VIOLET

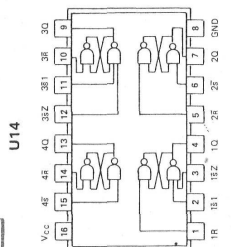
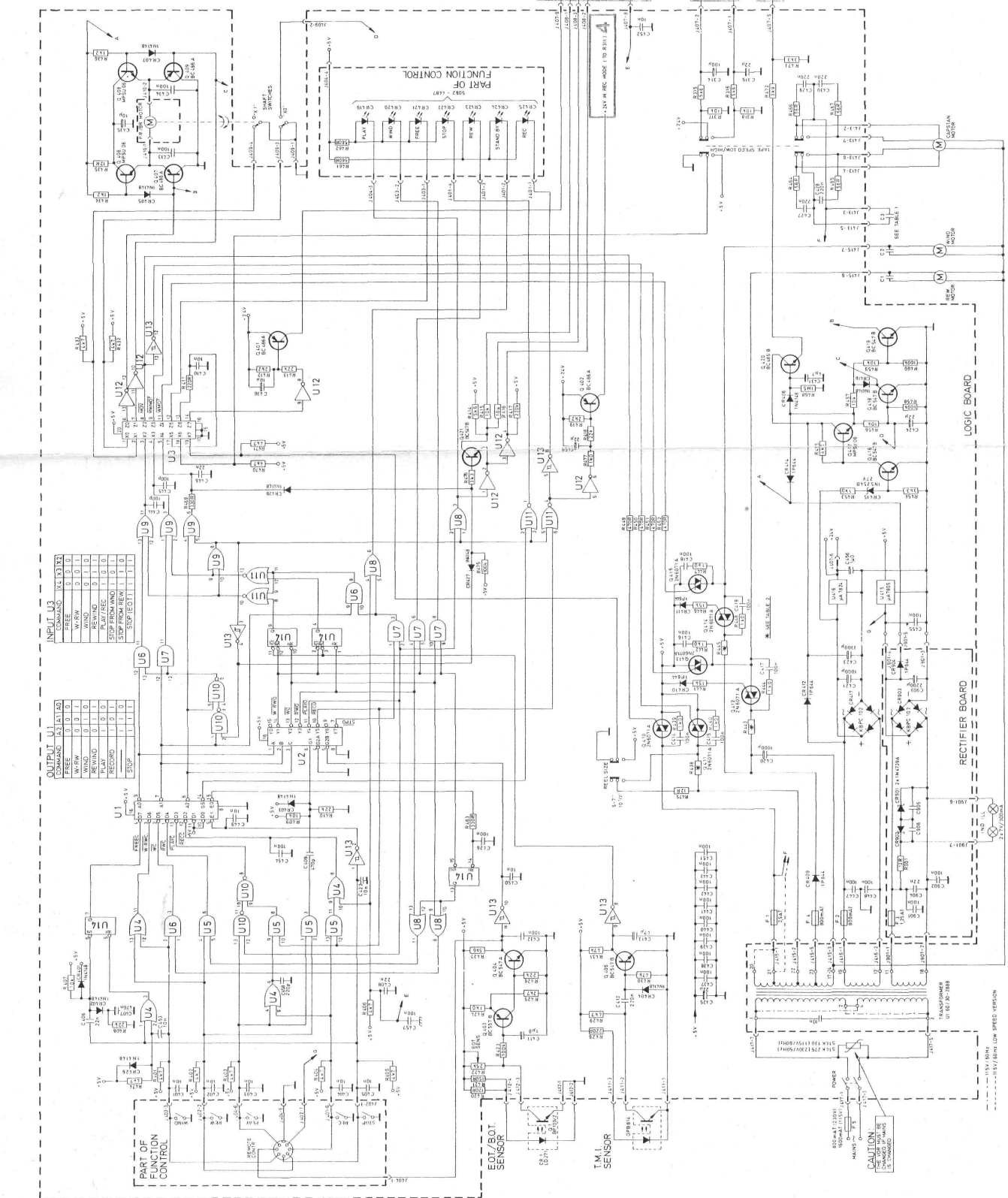

Function table

INPUTS	OUTPUT	
S*	R	Q ₀
1	1	0
0	1	1
1	0	0
0	0	1*

1 = High level
0 = Low level

Q₀ = the level of Q before the indicated input conditions were established.

* This output level is pseudo stable, that is, it may not persist when the s and r inputs return to their inactive (high) level.
** For latches with double s inputs:
1 = both s inputs high
0 = one or both s inputs low

LOGIC DIAGRAM

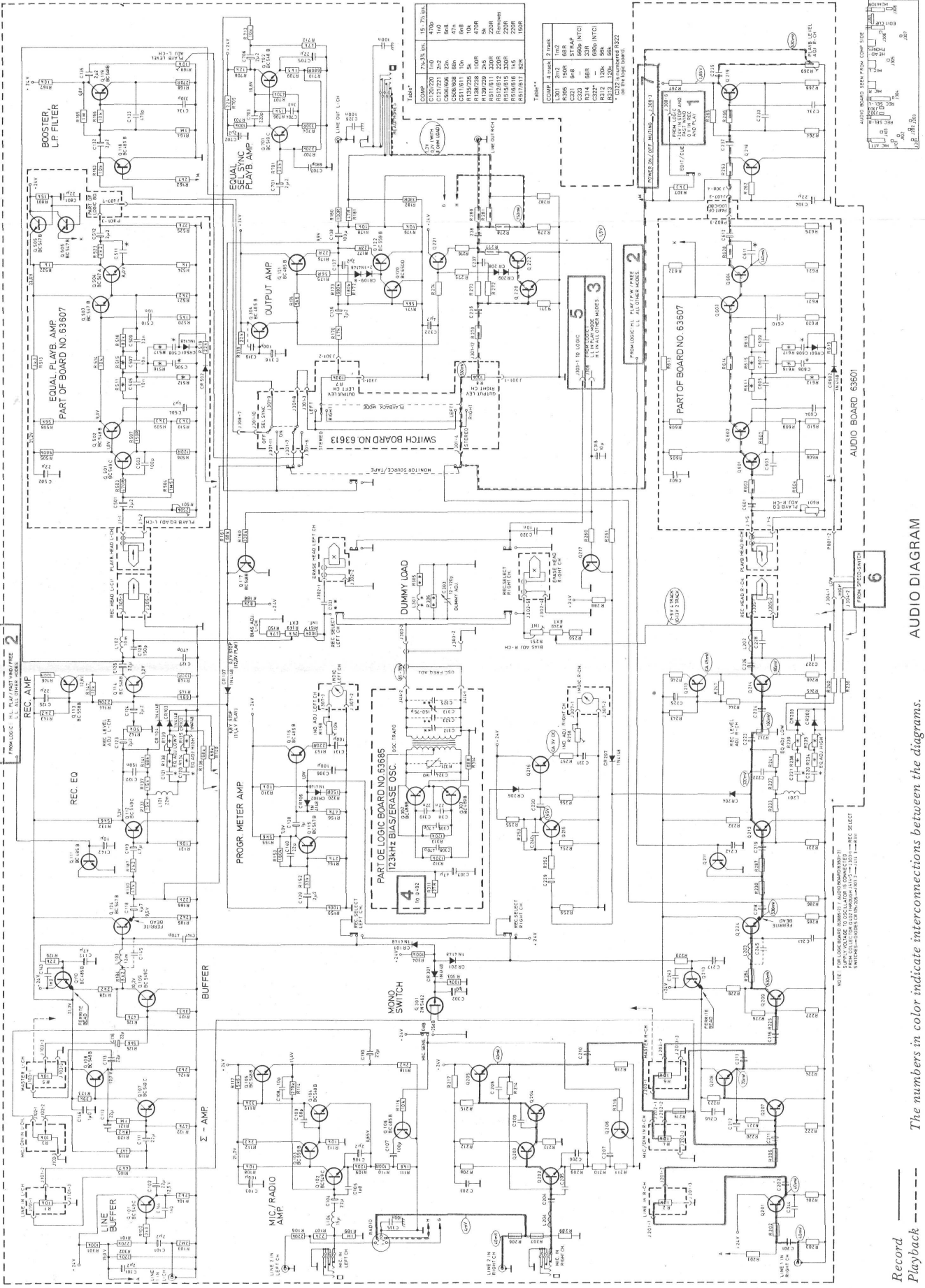

Record Playback

The numbers in color indicate interconnections between the diagrams.

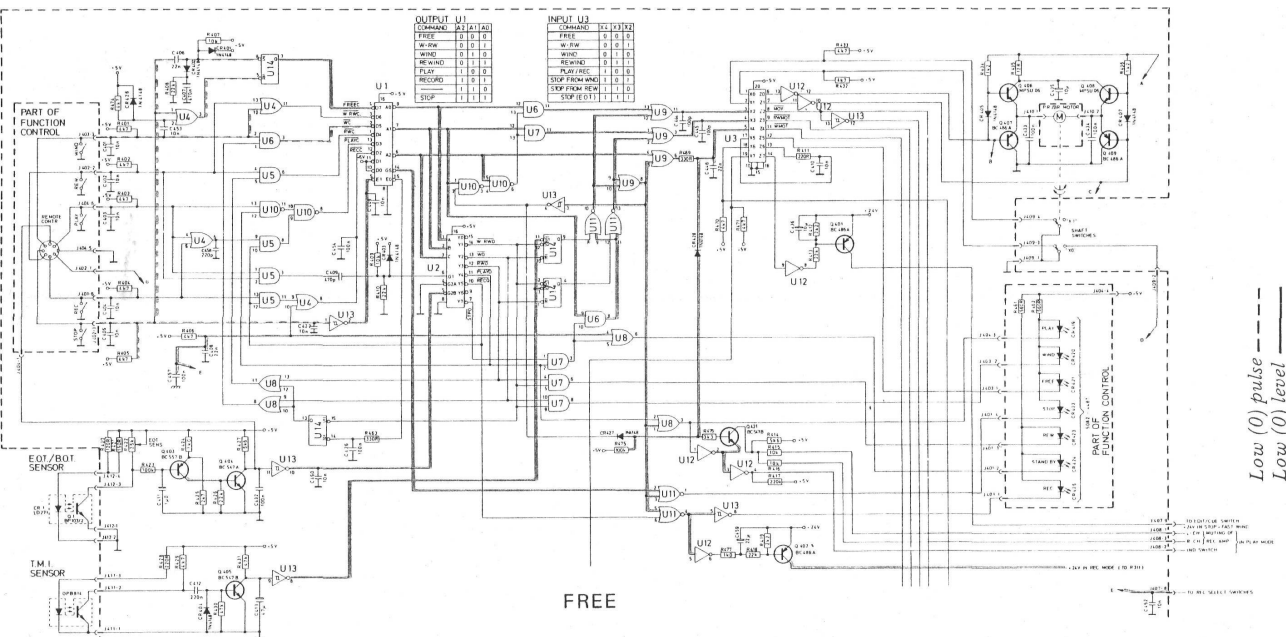
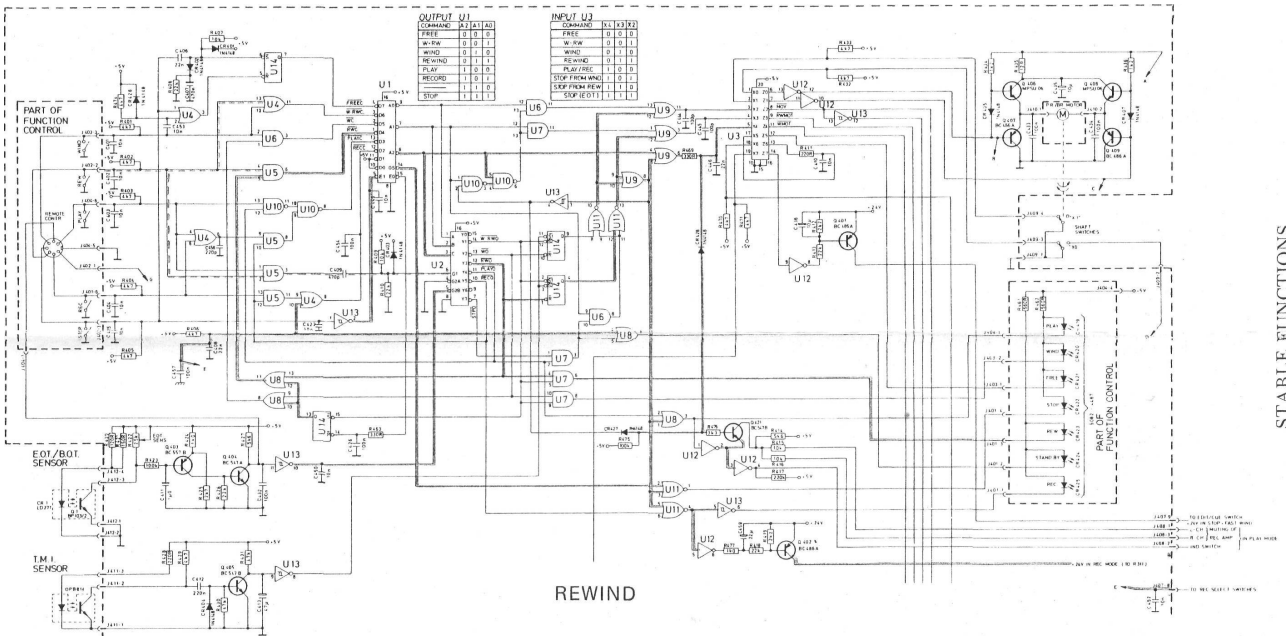
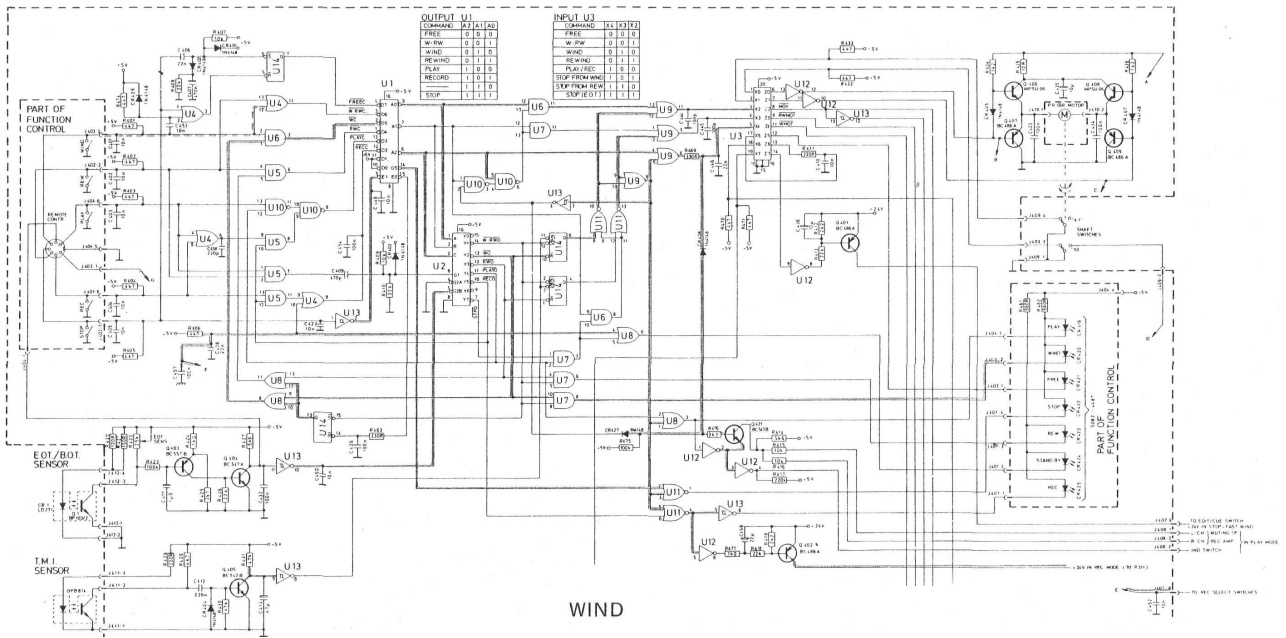

STABLE FUNCTIONS

Low (0) pulse ———
Low (0) level ———

STABLE FUNCTIONS

Low (0) pulse
Low (0) level

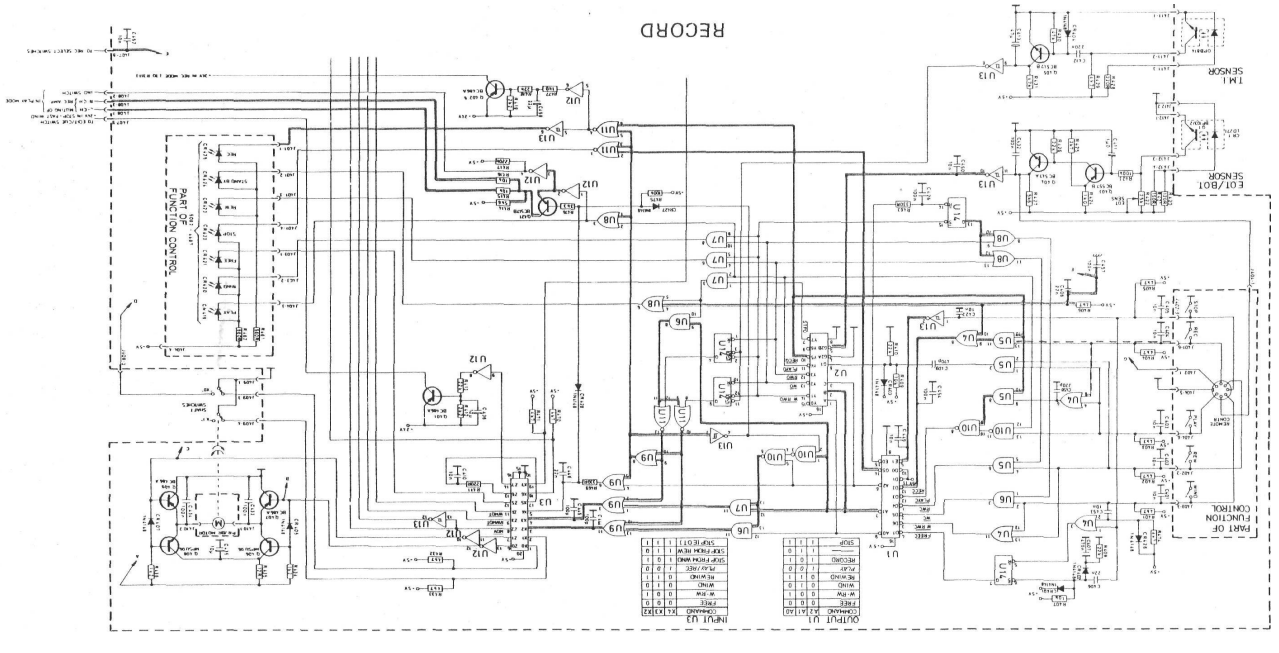
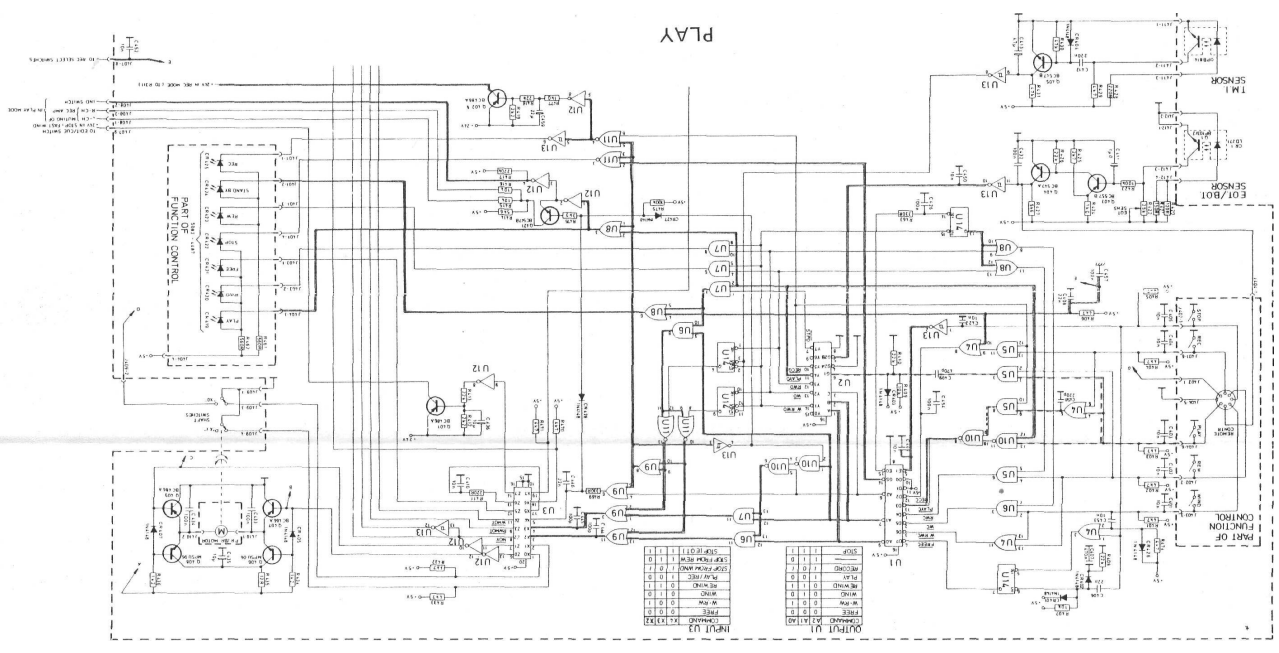
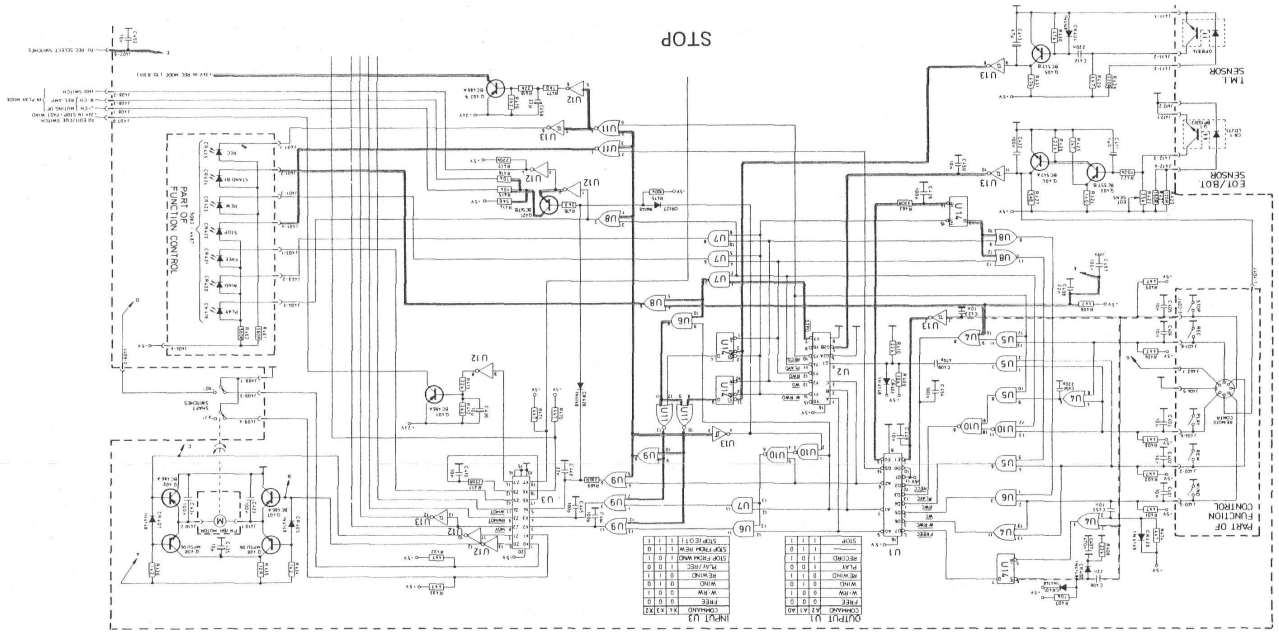

TANDBERG

TD 20 A

Circuit Diagrams with Alignment Instructions

Electrical adjustments TD 20A

Make the adjustments in the order in which they are listed here. Many of the adjustments require that previous adjustments have already been correctly made.

Clean and degauss the tape path before and after adjustments. It is assumed that the tape path has already been correctly adjusted as described in the Service Manual for the 9100X/9200XD (Part No. 715101).

Maxell UD XL or equivalent tapes should be used for recording.

Necessary equipment

- d.c. voltmeter
- 2 high impedance voltmeters (do NOT use universal meters)
- Frequency counter
- Audio generator
- Distortion meter
- Wow meter (required for wow test only)
- Test tapes:
 - No. 2 — Azimuth adj. playb. head 15,000 Hz, 7½ ips.
 - No. 3 - Playb. curve, DIN 19H, 7½ ips.
 - No. 4 - Playb. level adj., 400 Hz, 7½ ips.
 - No. 11 - Speed check, 1000 Hz, 7½ ips.

Bias Adjustment (Front panel)

Before adjustment, make sure that the Bias Adjustment potentiometers on the front panel are in the mid-position.

Checking the oscillator frequency

Connect a frequency counter inductively to the erase head. Connection is made with a coil or a few turns of ordinary wire. »

Adjust the frequency to 123.5 kHz in stereo recording with C313 on the logic board. Then check in mono, left and right, that the frequency are within ± 2 kHz. If outside the tolerance, adjust C303, DUMMY LOAD ADJ. on the audio board. Then check the frequency in stereo and mono left and right.

Checking the Bias Adj. (Front panel)

Connect an audio-generator to LINE 1. Start stereo recording at 7½" speed of a 22 kHz signal 30 dB below normal recording level (0 dB). Set the Monitor switch to Tape. Check that the output level measured with a.c. voltmeters on the LINE OUT are within approximately +3 dB to -5 dB when turning the Bias Adj. potentiometers.

After checking the Bias Adj., make sure that the potentiometers are set in the mid-position for use with Maxell UD XL or equivalent tapes.

Adjustment of EOT/BOT SENSOR

To be performed without tape. Measure with a d.c. voltmeter on pin 3, contact 412 on the logic board.

Adjust R422 (on the logic board) to 1.2 V reading on the voltmeter.

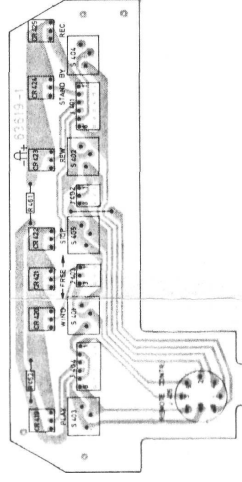

FUNCTION CONTROL BOARD, SOLDER SIDE

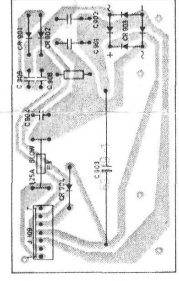

RECTIFIER BOARD, SOLDER SIDE

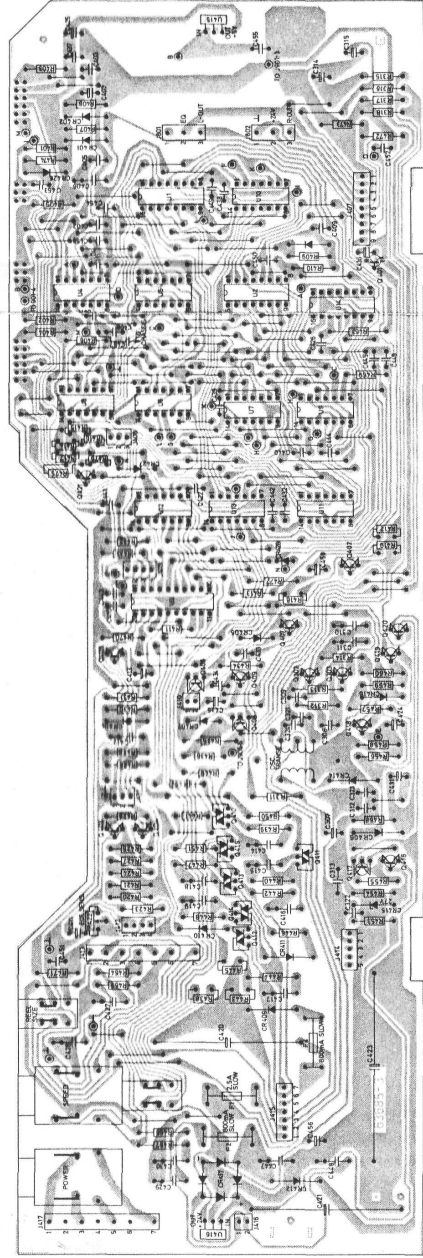

LOGIC BOARD, SOLDER SIDE

Test No. or check	Adjustment	Test tape No.	Set the deck to	Measuring instrument	Measure at	Adjust	Correct reading	Speed	Comments
1.1	Azimuth, playback head	2	Playback	a.c. voltmeters	LINE OUT	Azimuth playback head	Maximum output, see comments	754*	Maximum output or best compromise.
1.2	Playback curve, DIN 19H	3	Playback	a.c. voltmeters	LINE OUT	Playback E.Q. adj. R501-R601	+24dB at 18kHz	7 V	Playback curve, DIN 19H. The tape contains the following frequencies: 1000 Hz (reference) 18 kHz, 15 kHz, 10 kHz, 4 kHz, 125 Hz, 40 Hz 1000 Hz (ref.). Adjust R501-R601 to +2 dB at 18 kHz.
1.3	Playback level	4	Playback	a.c. voltmeters	LINE OUT	Playback level, R169-R269	1.0 volt	754*	
1.4	Speed	11*	Playback	Frequency counter	LINE OUT		±0.5% 995-1005 Hz in 754*		Test tape No. 11* is recorded at 1000 Hz in 754*.

* Test tape No. 11 is supplied on a small reel. This test tape should be spliced into a tape on a larger reel.

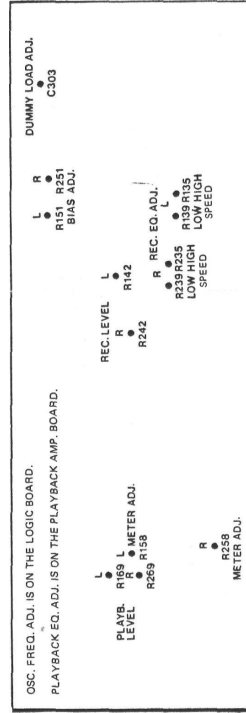

Location of adjustment points on the audio board, solder side.

Test No. or check	Adjustment	Measuring instrument	Measure at	Set the deck to	Monitor switch to	Procedure
2.1	Bias pre-adjustment	a.c. voltmeters	LINE OUT	Record. Speed: 3 3/4"	Tape	Connect an audio-generator to LINE 1. Set the generator to 6.3 kHz 30 dB below normal recording level (0 dB). Adjust R151 and R251 to maximum output level. Then turn R151 and R251 counter clockwise to — 2 dB from maximum reading.
2.2	Azimuth record head	a.c. voltmeters	LINE OUT	Record. Speed: 3 3/4"	Tape	Connect an audio-generator to LINE 1. Start stereo recording at 3 3/4" speed of a 1000 Hz signal 30 dB below normal recording level (0 dB). Use the voltmeter readings as reference level. Then record a 18,000 Hz signal and turn the azimuth screw on the record head to maximum reading or best compromise on the voltmeters.
2.3	Record/playback bias	a.c. voltmeters	LINE OUT	Record. Speed: 3 3/4"	Tape	Connect an audio-generator to LINE 1. Start recording in the 3 3/4" speed of a 1000 Hz signal 30 dB below normal recording level (0 dB). Use voltmeters readings as reference level. Then record a 18,000 Hz signal. Turn the generator to 48 kHz and adjust R139 and R239 to — 1 dB below the reference level. Then check that the output level do not deviate more than ± 3 dB from 20 Hz to 18,000 Hz.
2.4	Record/playback curves	a.c. voltmeters	LINE OUT	Record. Speed: 7 1/4"	Tape	Use the same recording level as in test 2.3. Use the voltmeters readings as reference level (1000 Hz). Turn the generator to 25 kHz and adjust R135 and R235 to — 1 dB below the reference level. Then check that the output level do not deviate more than ± 3 dB from 20 Hz to 25,000 Hz.
2.5	Source/Tape	a.c. voltmeters	LINE OUT	Record. Speed: 7 1/4"	Source/Tape	Connect an audio-generator 1000 Hz to LINE 1. Adjust in Source with the input levels to 0.6 V on the voltmeters on the LINE OUT. Set the deck to stereo recording and set the Monitor switch to Tape. Then adjust R142 and 3242 so that the level reading is 1 dB higher on the voltmeters.
2.6	Program meter adjustment	a.c. voltmeters	LINE OUT	Speed: 7 1/4"	Source	Audio-generator 1000 Hz to LINE 1. Set the Monitor switch to Source. Adjust with the Input Levels to 1.5 V reading on the voltmeters. Then adjust the program meters to 0 dB with R158 and R258 (Output Left and Right on maximum).
2.7	Distortion	Distortion meter	LINE OUT	Record. Speed: 7 1/4"	Tape	Connect an audio-generator, 1000 Hz, (or distortion meter generator) to LINE 1. Connect the program meters, and read the distortion on the LINE OUT. Distortion maximum 2%.
2.8	Wow and flutter	Wow and flutter meter	LINE OUT	Record.	Tape	Connect the wow and flutter meter to LINE 1. Read on the LINE OUT in highest and lowest speed: Wow and flutter max.: 3 3/4" 7 1/4" 15" Weighted RMS: 0.10% 0.05% 0.03% Peak value DIN 45500 P.4: 0.14% 0.08% 0.06%

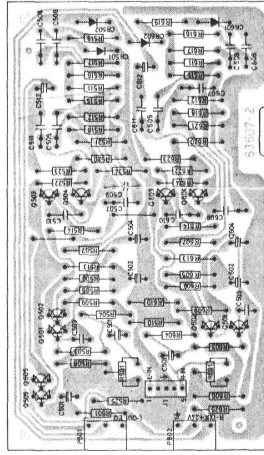

PLAYBACK AMP. BOARD, SOLDER SIDE

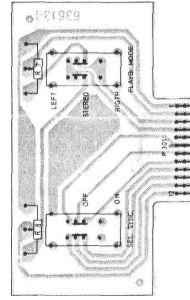

SWITCH BOARD, SOLDER SIDE

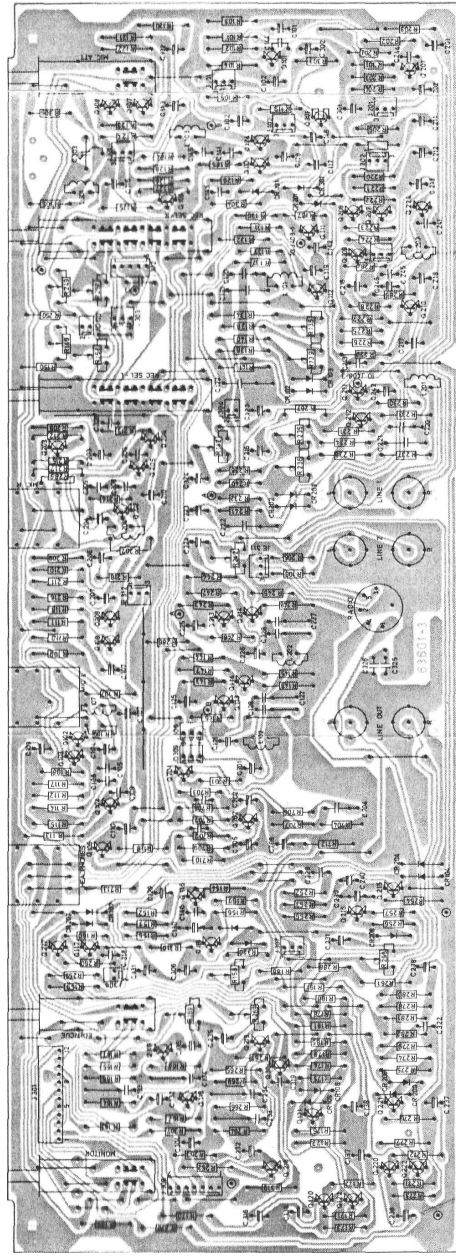

AUDIO BOARD, SOLDER SIDE

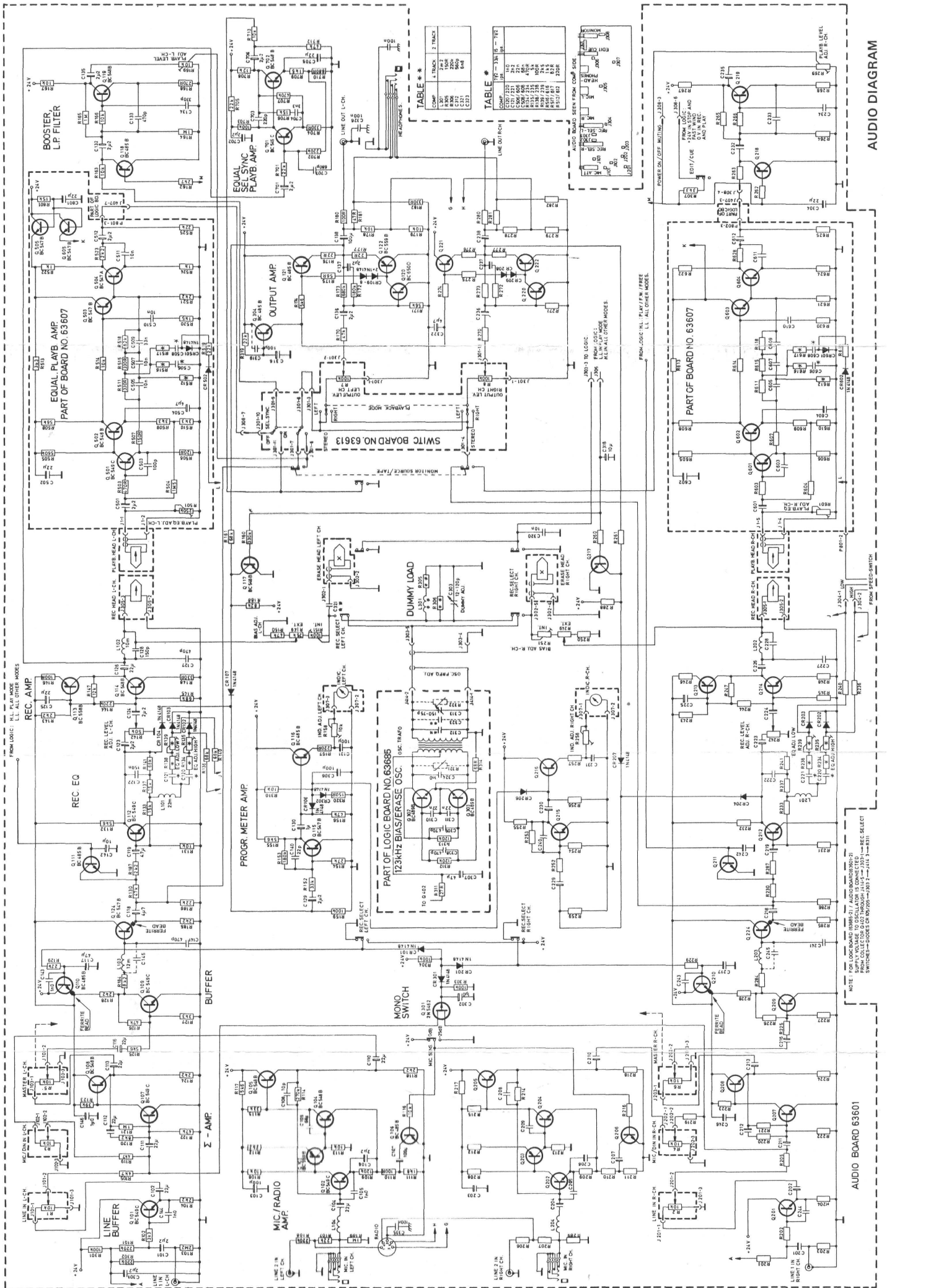

AUDIO DIAGRAM

AUDIO BOARD 63601

NOTE: FOR LOW-IMPEDANCE (8Ω-20Ω) AUDIO HEADPHONES, SUPPLY VOLTAGE TO OSCILLATOR IS CONNECTED TO SWITCHES—DO NOT CONNECT TO J1-1, J1-2, J1-3.

TABLE * * *

COMP.	1 TRACK	2 TRACK	3 TRACK
C101	100K	100K	100K
C102	100K	100K	100K
C103	100K	100K	100K
C104	100K	100K	100K
C105	100K	100K	100K
C106	100K	100K	100K
C107	100K	100K	100K
C108	100K	100K	100K
C109	100K	100K	100K
C110	100K	100K	100K
C111	100K	100K	100K
C112	100K	100K	100K
C113	100K	100K	100K
C114	100K	100K	100K
C115	100K	100K	100K
C116	100K	100K	100K
C117	100K	100K	100K
C118	100K	100K	100K
C119	100K	100K	100K
C120	100K	100K	100K
C121	100K	100K	100K
C122	100K	100K	100K
C123	100K	100K	100K
C124	100K	100K	100K
C125	100K	100K	100K
C126	100K	100K	100K
C127	100K	100K	100K
C128	100K	100K	100K
C129	100K	100K	100K
C130	100K	100K	100K
C131	100K	100K	100K
C132	100K	100K	100K
C133	100K	100K	100K
C134	100K	100K	100K
C135	100K	100K	100K
C136	100K	100K	100K
C137	100K	100K	100K
C138	100K	100K	100K
C139	100K	100K	100K
C140	100K	100K	100K
C141	100K	100K	100K
C142	100K	100K	100K
C143	100K	100K	100K
C144	100K	100K	100K
C145	100K	100K	100K
C146	100K	100K	100K
C147	100K	100K	100K
C148	100K	100K	100K
C149	100K	100K	100K
C150	100K	100K	100K
C151	100K	100K	100K
C152	100K	100K	100K
C153	100K	100K	100K
C154	100K	100K	100K
C155	100K	100K	100K
C156	100K	100K	100K
C157	100K	100K	100K
C158	100K	100K	100K
C159	100K	100K	100K
C160	100K	100K	100K
C161	100K	100K	100K
C162	100K	100K	100K
C163	100K	100K	100K
C164	100K	100K	100K
C165	100K	100K	100K
C166	100K	100K	100K
C167	100K	100K	100K
C168	100K	100K	100K
C169	100K	100K	100K
C170	100K	100K	100K
C171	100K	100K	100K
C172	100K	100K	100K
C173	100K	100K	100K
C174	100K	100K	100K
C175	100K	100K	100K
C176	100K	100K	100K
C177	100K	100K	100K
C178	100K	100K	100K
C179	100K	100K	100K
C180	100K	100K	100K
C181	100K	100K	100K
C182	100K	100K	100K
C183	100K	100K	100K
C184	100K	100K	100K
C185	100K	100K	100K
C186	100K	100K	100K
C187	100K	100K	100K
C188	100K	100K	100K
C189	100K	100K	100K
C190	100K	100K	100K
C191	100K	100K	100K
C192	100K	100K	100K
C193	100K	100K	100K
C194	100K	100K	100K
C195	100K	100K	100K
C196	100K	100K	100K
C197	100K	100K	100K
C198	100K	100K	100K
C199	100K	100K	100K
C200	100K	100K	100K