

TANDBERG® TD 20 A-SE

Circuit Diagrams and Alignment Instructions

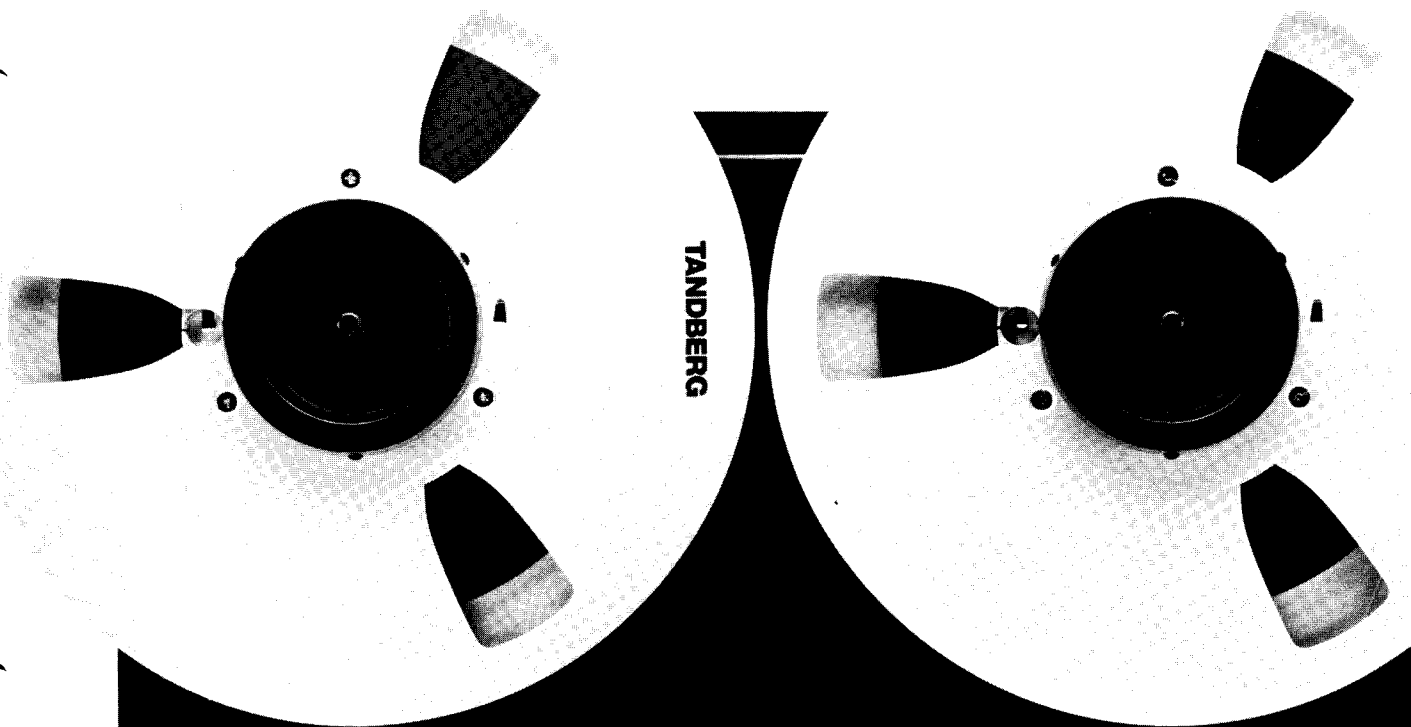

Electrical adjustments TD 20A—SE

Make the adjustments in the order in which they are listed here. Many of the adjustments require that previous adjustments have already been correctly made.

Clean and degauss the tape path before and after adjustments. It is assumed that the tape path has already been correctly adjusted as described in the Service Manual for the TD 20A, part No. 714127.

Maxell UD XL or equivalent tapes should be used for recording.

Necessary equipment

- d.c. voltmeter.
- 2 high impedance voltmeters (do NOT use universal meters).
- Frequency counter.
- Audio generator.
- Distortion meter.
- Wow meter (required for wow test only).
- Test tapes:
 - No. 2 — Azimuth adjustment playback head, 15,000 Hz, 7½ ips.
 - No. 3 — Playback curve, DIN 19H, 7½ ips.
 - No. 4 — Playback level adjustment, 400 Hz, 7½ ips.
 - No. 11 — Speed check, 1000 Hz, 7½ ips.

Bias Adjustment (front panel)

Before adjustment, make sure that the Bias Adjustment potentiometers on the front panel are in the mid-position.

Checking the oscillator frequency

Connect a frequency counter directly to the record head.

Adjust the frequency to 123.5 kHz in stereo recording with C313 on the logic board. Then check in mono, left and right, that the frequency are within ± 2 kHz. If outside the tolerance, adjust C303, DUMMY LOAD ADJ. on the audio board. Then check the frequency in stereo and mono left and right.

Checking the Bias Adjustment (front panel)

Connect an audio-generator to LINE 1. Start stereo recording at 7½ ips speed of a 22 kHz signal 30 dB below normal recording level (0 dB). Set the Monitor switch to Tape. Check that the output level measured with a.c. voltmeters on the LINE OUT are within approximately + 3 dB to - 5 dB when turning the Bias Adjustment potentiometers.

Adjustment of EOT/BOT sensor

To be performed without tape. Measure with a d.c. voltmeter on pin 3, contact 412 on the logic board.

Adjust R422 (on the logic board) to 1.2 V reading on the voltmeter.

Test Adjustment No. or check	Test tape No.	Set the deck to	Measuring instrument	Measure at	Adjust	Correct reading	Speed	Comments
1.1 Azimuth, playback head	2	Playback. Equalization: Normal.	a.c. voltmeters	LINE OUT	Azimuth screw, playback head	Maximum output, see comments	7½ ips.	Maximum output or best compromise.
1.2 Playback curve DIN 19H	3	Playback. Equalization: Normal.	a.c. voltmeters	LINE OUT	Playback E.Q. adj. R501/R601	+ 2 dB at 18 kHz	7½ ips.	Playback curve, DIN 19H. The tape contains the following frequencies: 1000 Hz (reference) 18 kHz, 15 kHz, 10 kHz, 4 kHz, 125 Hz, 40 Hz 1000 Hz (ref.). Adjust R501/R601 to + 2 dB at 18 kHz.
1.3 Playback level	4	Playback. Equalization: Normal or Special.	a.c. voltmeters	LINE OUT	Playback level R169/R269	0.9 volt	7½ ips.	
1.4 Speed	11*	Playback.	Frequency counter	LINE OUT		$\pm 0.5\%$ 995–1005 Hz in 7½ ips.		Test tape No. 11* is recorded at 1000 Hz in 7½ ips.

* Test tape No. 11 is supplied on a small reel. This test tape should be spliced into a tape on a larger reel.

Test No.	Adjustment or check	Measuring instrument	Measure at	Set the deck to	Monitor switch to	Procedure																
2.1	Bias pre-adjustment	a.c. voltmeters	LINE OUT	Record. Speed: 7½ ips. Equalization: Normal.	Tape	Connect an audio-generator to LINE 1. Set the generator to 12.5 kHz 30 dB below normal recording level (0 dB). Adjust R151 and R251 to maximum output level. Then turn R151 and R251 counter clockwise to - 2 dB from maximum reading.																
2.2	Azimuth, record head	a.c. voltmeters	LINE OUT	Record. Speed: 7½ ips. Equalization: Normal.	Tape	Connect an audio-generator to LINE 1. Start recording at 7½ ips. of a 1000 Hz signal 30 dB below normal recording level (0 dB). Use the voltmeter readings as reference level. Then record a 25,000 Hz signal and turn the azimuth screw on the record head to maximum reading or best compromise on the voltmeters.																
2.3	Record/playback curves	a.c. voltmeters	LINE OUT	Record. Speed: 7½ ips. Equalization: Normal.	Tape	Connect an audio-generator to LINE 1. Start recording of a 1000 Hz signal 30 dB below normal recording level (0 dB). Use the voltmeters readings as reference level (0 dB). Then turn the generator to 12.5 kHz and adjust R151 and R251 to 0.5 dB from the reference level. Turn the generator to 25 kHz and adjust R139 and R239 to 0 dB. Check that the output level do not deviate more than ± 2 dB from 20 Hz to 25,000 Hz.																
2.4	Record/playback curves	a.c. voltmeters	LINE OUT	Record. Speed: 15 ips. Equalization: Normal.	Tape	Use the same recording level as in test 2.3. Use the voltmeters readings as reference level. Check that the output level do not deviate more than ± 3 dB from 20 Hz to 30,000 Hz. Adjust if necessary with PLAYBACK E.Q. ADJ. R501/R601 and/or BIAS ADJ. R151/R251. If re-adjustment is done, check once again that the output level in 7½ ips, Equalization: Normal do not deviate more than ± 2 dB from 20 Hz to 25,000 Hz. Adjust if necessary with R139/R239.																
2.5	Record/playback curves	a.c. voltmeters	LINE OUT	Record. Speed: 15 ips. Equalization: Special.	Tape	Use the same recording level as in test 2.3. Use the voltmeters readings as reference level. Turn the generator to 30 kHz and adjust R135/R235 to 0 dB. Check that the output level do not deviate more than ± 2 dB from 20 Hz to 30,000 Hz.																
2.6	Record/playback curves	a.c. voltmeters	LINE OUT	Record. Speed: 7½ ips. Equalization: Special.	Tape	Use the same recording level as in test 2.3. Use the voltmeters readings as reference level. Check that the output level do not deviate more than ± 2 dB from 20 Hz to 25,000 Hz.																
2.7	Source/Tape	a.c. voltmeters	LINE OUT	Record. Speed: 7½ ips. Equalization: Normal.	Source/Tape	Connect an audio-generator 1000 Hz to LINE 1. Adjust in Source with the Input Levels to 0.6 V on the voltmeters on the LINE OUT. Set the deck to stereo recording and set the Monitor switch to Tape. Then adjust R142 and R242 so that the level reading is 1 dB higher on the voltmeters.																
2.8	Program meter adjustment	a.c. voltmeters	LINE OUT	Speed: 7½ ips. Equalization: Normal.	Source	Connect an audio-generator 1000 Hz to LINE 1. Set the Monitor switch to Source. Adjust with the Input Levels to 1.5 V reading on the voltmeters. Then adjust the program meters to 0 dB with R158 and R258 (Output Left and Right on maximum).																
2.9	DYNEQ® level adjustment	Program meters	LINE OUT	Speed: 7½ ips. Equalization: Normal.	Source	Connect an audio generator to LINE 1. Set the generator to 1 kHz. Adjust with the input levels to - 3 dB on the program meters. Then set the generator to 18 kHz and set the program meters to + 2 dB with the DYNEQ SENSITIVITY ADJ. (on left side of the chassis).																
2.10	Distortion	a.c. voltmeter/ distortion meter	LINE OUT	Record. Speed: 7½ ips. Equalization: Normal.	Tape	Connect an audio-generator at 1000 Hz or the distortion meter generator to LINE 1. Record to 0.9 V reading on the voltmeters and read the distortion on the LINE OUT. Distortion maximum 0.5%.																
2.11	Wow and flutter	Wow and flutter meter	LINE OUT	Record.	Tape	Connect the wow and flutter meter to LINE 1. Read on the LINE OUT in highest and lowest speed: <table border="0"> <tr> <td></td> <td>3% ips.</td> <td>7½ ips.</td> <td>15 ips.</td> </tr> <tr> <td>Wow and flutter maximum:</td> <td></td> <td></td> <td></td> </tr> <tr> <td>Weighted RMS</td> <td>0.10%</td> <td>0.05%</td> <td>0.03%</td> </tr> <tr> <td>Peak value DIN 45500 P.4.</td> <td>0.14%</td> <td>0.08%</td> <td>0.06%</td> </tr> </table>		3% ips.	7½ ips.	15 ips.	Wow and flutter maximum:				Weighted RMS	0.10%	0.05%	0.03%	Peak value DIN 45500 P.4.	0.14%	0.08%	0.06%
	3% ips.	7½ ips.	15 ips.																			
Wow and flutter maximum:																						
Weighted RMS	0.10%	0.05%	0.03%																			
Peak value DIN 45500 P.4.	0.14%	0.08%	0.06%																			

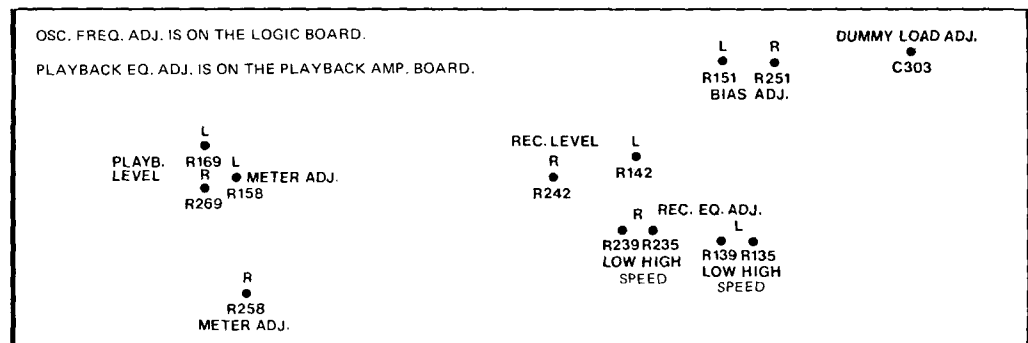

Location of Adjustment points on the Audio Board, solder side

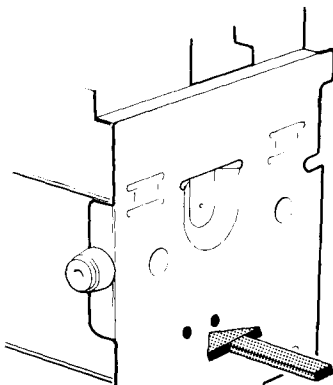

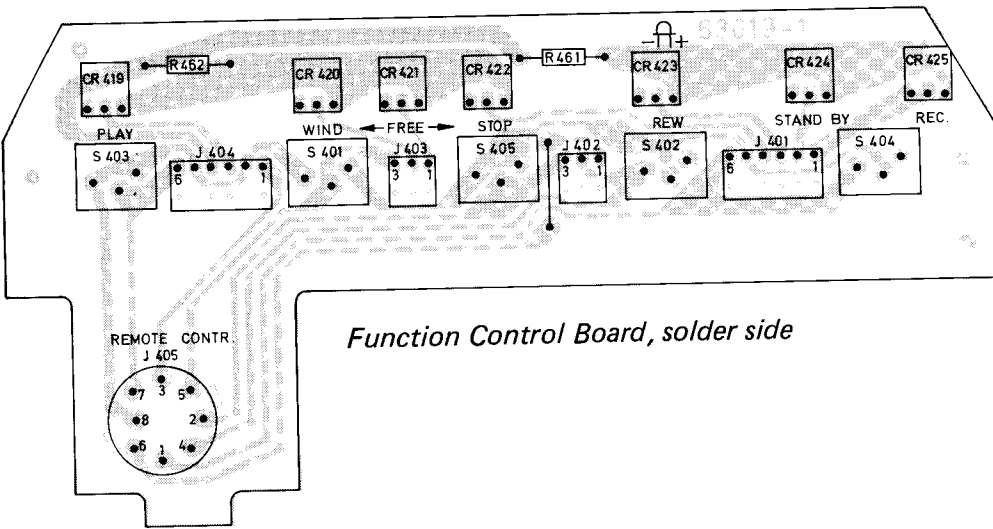

Function Control Board, solder side

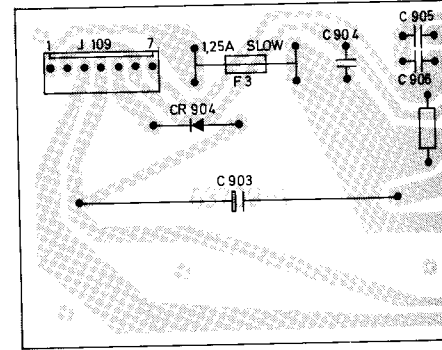

Rectifier Board, solder side

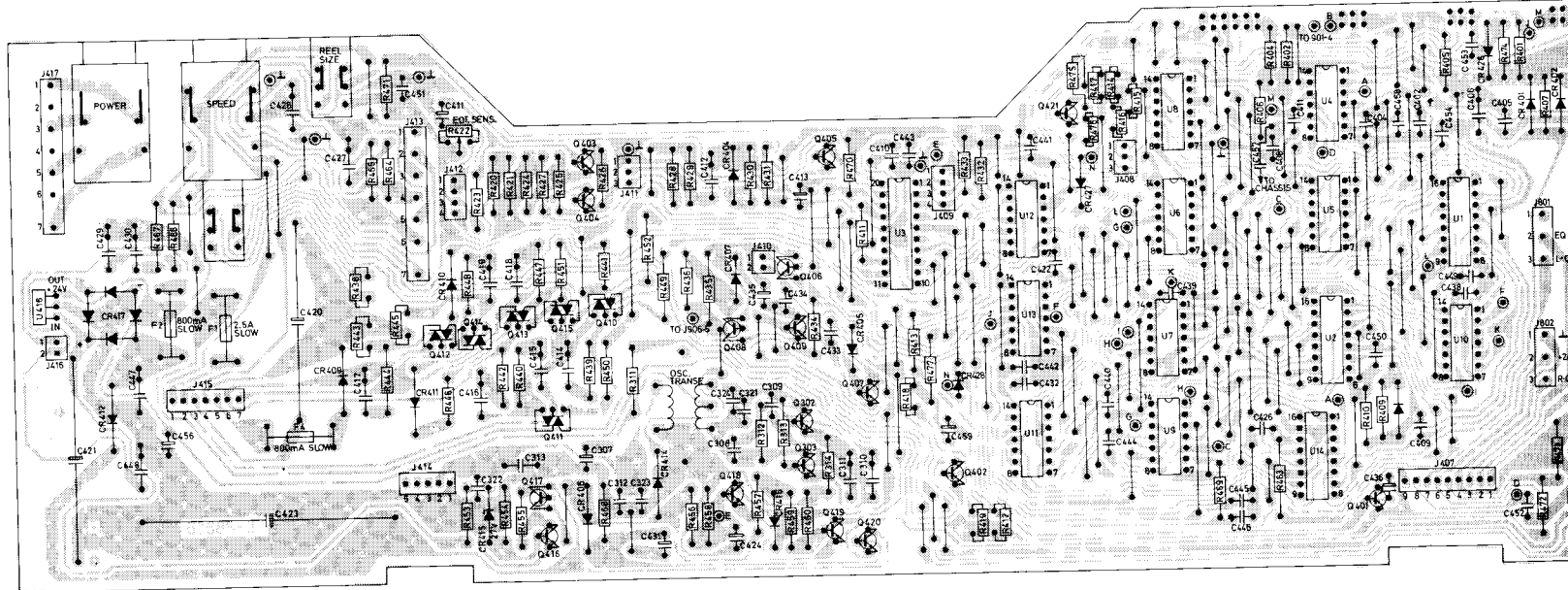

Logic Board, solder side

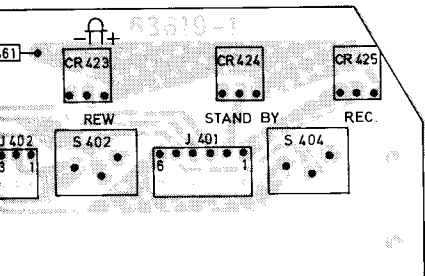

Board, solder side

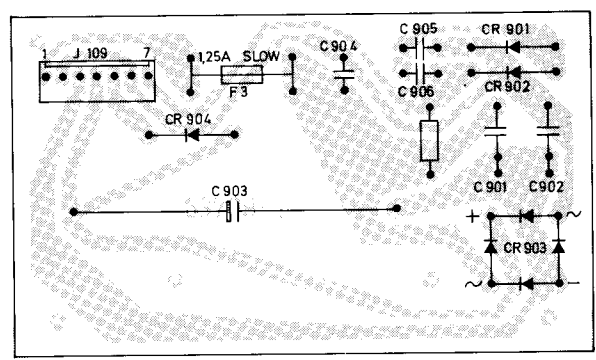

Rectifier Board, solder side

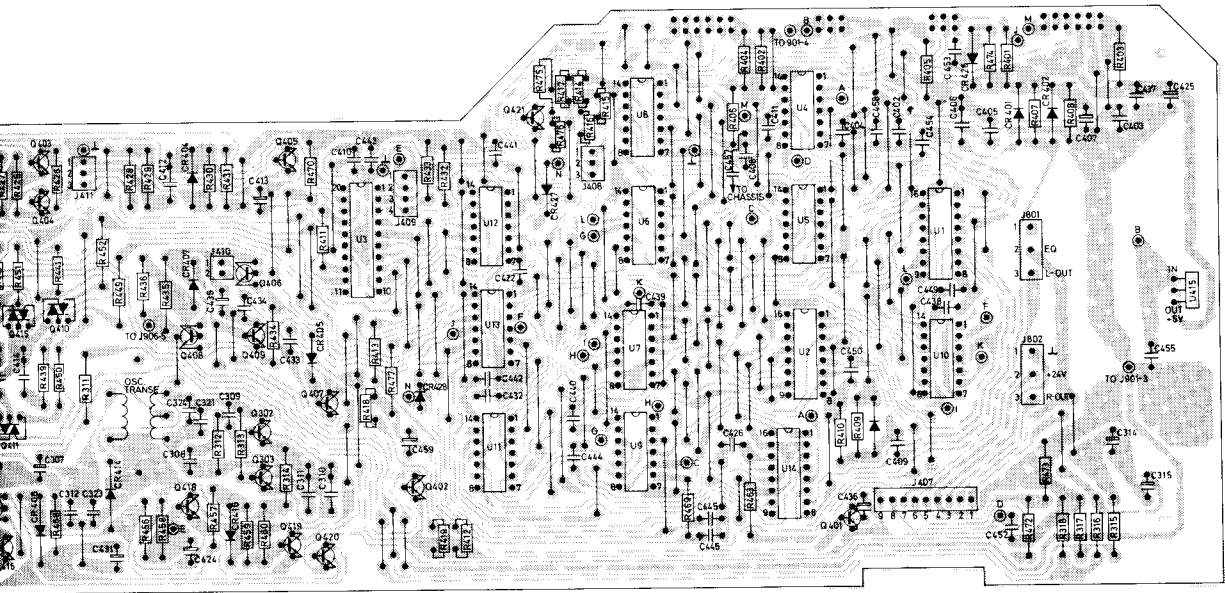

Logic Board, solder side

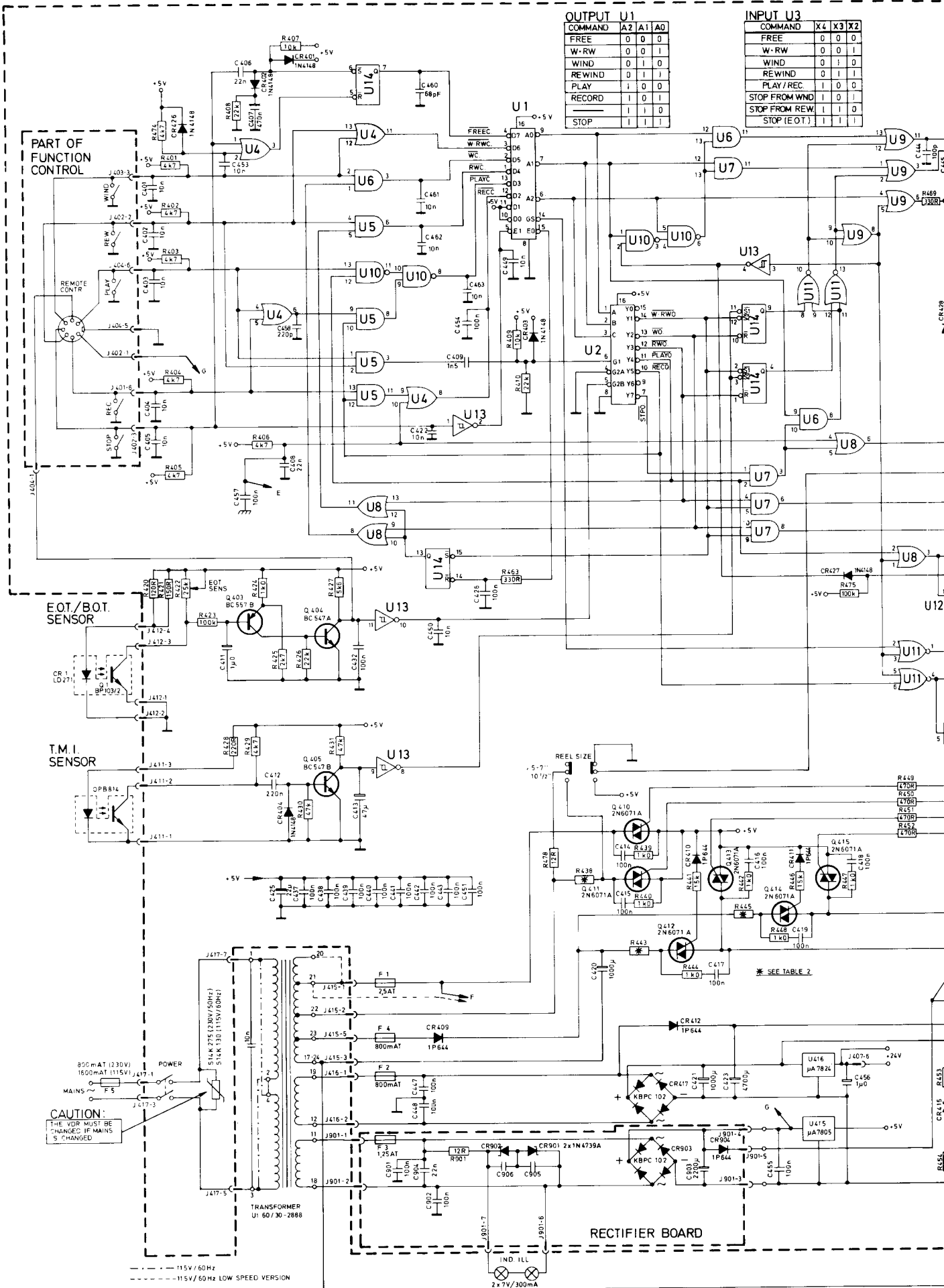

OUTPUT U1

COMMAND	A2	A1	A0
FREE	0	0	0
W-RW	0	0	1
WIND	0	1	0
REWIND	0	1	1
PLAY	1	0	0
RECORD	1	0	1
STOP	1	1	1

INPUT U3

COMMAND	X4	X3	X2
FREE	0	0	0
W-RW	0	0	1
WIND	0	0	1
REWIND	0	1	1
PLAY/REC.	1	0	0
STOP FROM WIND	1	0	1
STOP FROM REW.	1	1	0
STOP (EOT)	1	1	1

PART OF FUNCTION CONTROL

E.O.T./B.O.T. SENSOR

T.M.I. SENSOR

RECTIFIER BOARD

CAUTION:
THE VDR MUST BE
CHANGED IF MAINS
IS CHANGED

--- 115V/60Hz
- - - - - 115V/60Hz LOW SPEED VERSION

SEE TABLE 2

POWER
800 mA T (230V)
1600 mA T (115V)

TRANSFORMER
U1 60/30-2888

REEL SIZE
5-7 1/2
10 1/2

5V

5V

5V

5V

5V

5V

5V

5V

5V

5V

5V

5V

5V

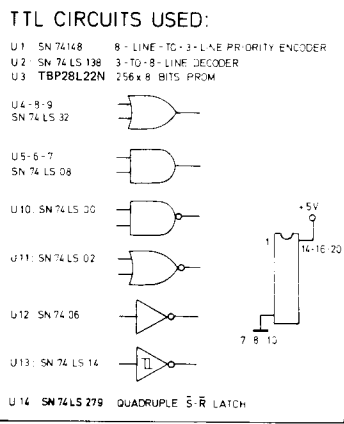
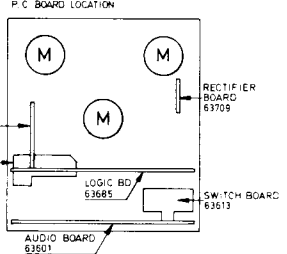
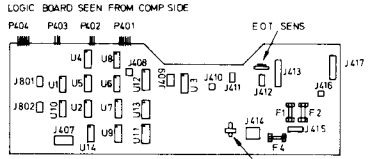
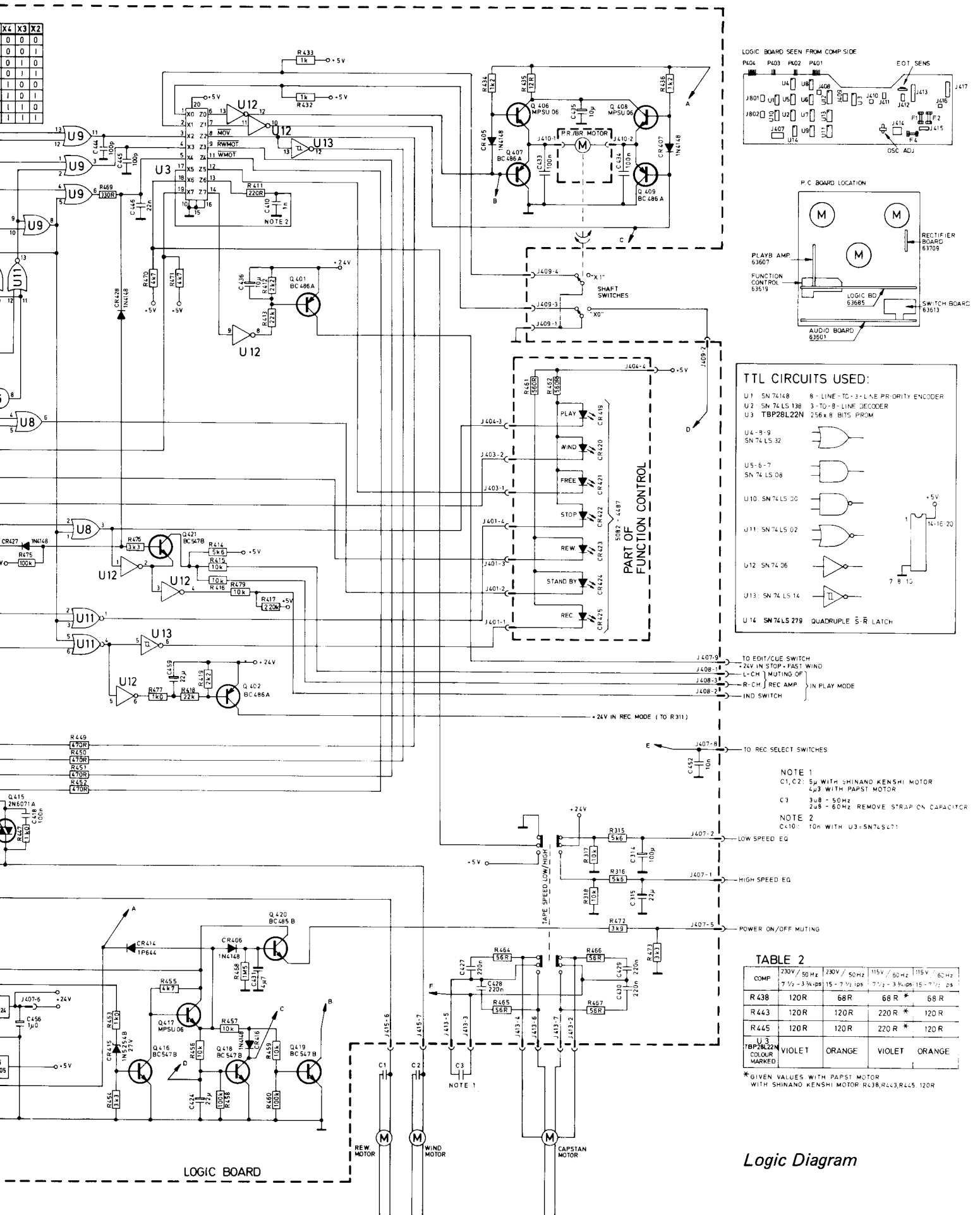

TO EOT/CUE SWITCH J407-9

-24V IN STOP - FAST WIND J408-1

L-CH MUTING OF J408-3

R-CH REC AMP IN PLAY MODE J408-2

IND SWITCH J408-4

TO REC SELECT SWITCHES J407-8

NOTE 1

C1, C2: 5μ WITH SHINANO KENSHI MOTOR
4.3μ WITH PAPT MOTOR

C3 3μ8 - 50Hz
2μ8 - 60Hz REMOVE STRAP ON CAPACITOR

NOTE 2

C410: 10n WITH U3-SNTCSL11

J407-2 LOW SPEED EQ

J407-1 HIGH SPEED EQ

J407-5 POWER ON/OFF MUTING

TABLE 2

COMP	230V / 50 Hz 7 1/2 - 3 kVA, ps	230V / 50 Hz 15 - 7 1/2 kVA, ps	115V / 60 Hz 7 1/2 - 3 kVA, ps	115V / 60 Hz 15 - 7 1/2 kVA, ps
R 438	120R	68R	68 R *	68 R
R 443	120R	120R	220R *	120 R
R 445	120R	120R	220 R *	120 R
TBP28L22N COLOUR MARKED	VIOLET	ORANGE	VIOLET	ORANGE

* GIVEN VALUES WITH PAPT MOTOR
WITH SHINANO KENSHI MOTOR R438, R443, R445 120R

Logic Diagram

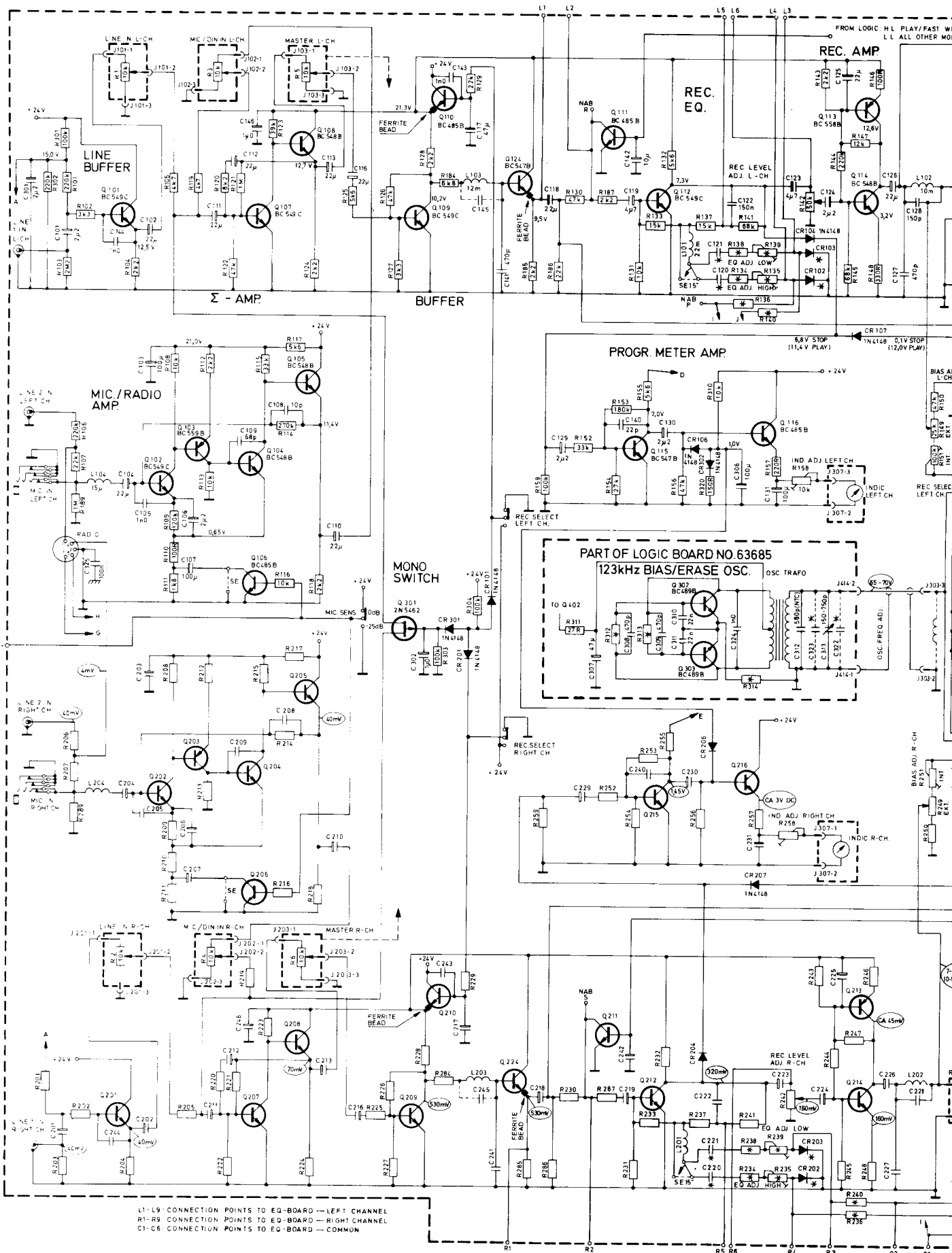

L1-L9 CONNECTION POINTS TO EQ-BOARD — LEFT CHANNEL
 R1-R9 CONNECTION POINTS TO EQ-BOARD — RIGHT CHANNEL
 C1-C6 CONNECTION POINTS TO EQ-BOARD — COMMON

Audio Diagram

Tandberg - The European Alternative

Tandberg A/S

Fetveien 1, P.O. Box 53

N-2007 Kjeller, Norway