

TANDBERG® TCA 3038A

Operating Instructions

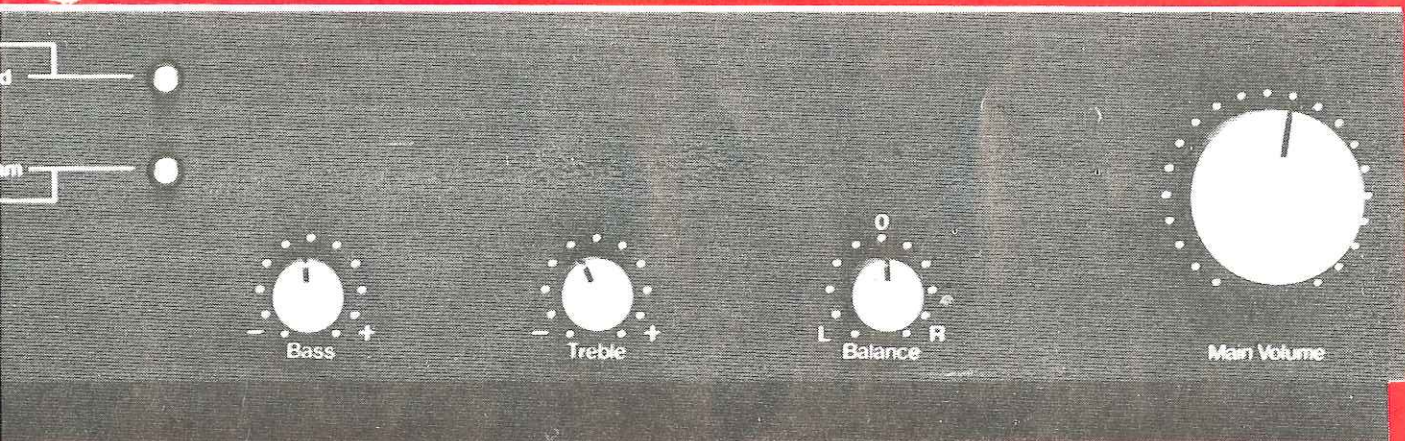

READ THIS FIRST!

For your safety!

To prevent electrical shock or fire, do not expose electronic products to rain or moisture, and do not remove covers (or back). If anything fails, leave the repair to a qualified technician.

Pull out the power plug during thunder storms and when you are away for a long time (e.g. holidays, etc.).

Warning!

Faults on the units caused by the circumstances described in the warnings below, do not necessarily apply for warranty service.

Main power

In some areas the main power wall outlet carries high frequency data and intercom communications. To prevent this high frequency to reach the tuner/control amplifier, an HF filter should be connected in the power line. Ask your local Tandberg dealer if this high frequency is in your area. Should this high frequency reach the tuner/control amplifier, and interfere with the electronics, damage may occur in the outputstage or the speakers.



Connecting

When connecting the units in a HI-FI system together, it is very easy to touch the hot wire on the phono lead and generate a hum signal. This signal can be amplified and cause damage to the tuner/control amplifier or the speakers. To avoid this problem, switch off all the units in the system before connecting.

Contents

	Page
Power Requirements	3
Connecting external equipment	3
Switching on	5
Headphones	5
Volume – Balance	5
Tone Defeat	6
Bass – Treble	6
Loudness	6
Program selector	7
Record selector	7
Remote Control operation	8
Accessories (extras)	10
Technical Data	11

Power Requirements

Make sure the control amplifier is marked at the rear panel with the correct mains voltage for your area*:

US version: 110 – 115 V ± 10 %, 50/60 Hz
 European version: 220 – 230 V ± 10 %, 50/60 Hz
 GB version: 240 V ± 10 %, 50/60 Hz

Changing the mains voltage setting and fuse (inside) should be carried out by a qualified service technician.

The power consumption is 35 watt maximum.

Fuses: Fuse: 5 x 20 mm slow blow
 220 V/240 V: Eu: T 160 mA nm.
 115 V: US: T 400 mA nm.

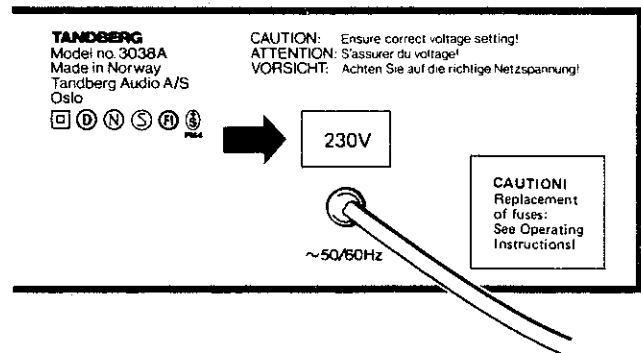

Check that the control amplifier is marked with the correct mains voltage.

Connecting external equipment

Important!: All connections must be carried out **before** the Power is switched on.*

CAUTION! When connecting a record player, do not use phono plugs with center terminal longer than 15 mm, see figure. At the bottom of each phono socket there is a switch which can be damaged if the plug is too long.

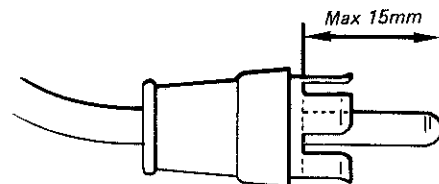

Record player

Only one record player must be connected at the same time.

- Connect the record player as shown.
- Phono MC: Record player with moving-coil pick-up.
- Phono MM: Record player with moving-magnet pick-up.
- The ground lead (static) from the record player must be connected to the ground terminal.

If no record player is connected the noise level from the phono amplifier will be higher than normal. To minimize this noise level connect shorting plugs to the MM phono input.

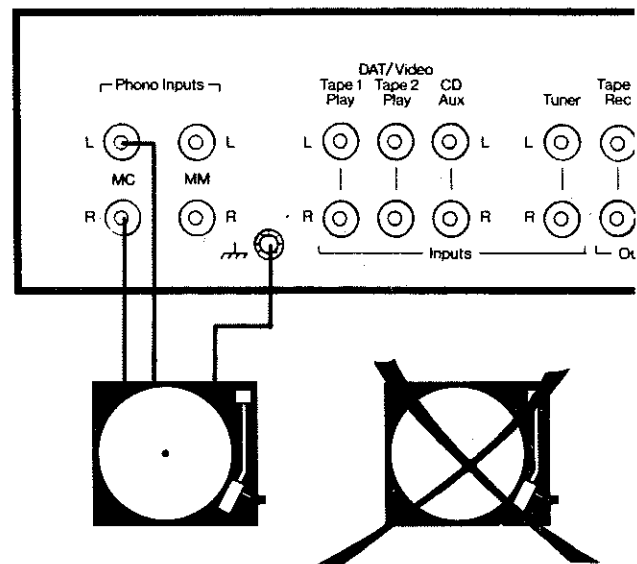

Only one record player must be connected at the same time.

* See page 2.

High level inputs

NOTE! All high level inputs, except phono, are identical, and therefore the sources can be exchanged. If exchanging the inputs, note that the text on the front no longer matches the connected equipment. For example you can connect four CD players.

For best performance use High Resolution phono cables for interconnection (in- and outputs) between the TCA 3038A and the external equipment.

Tape/cassette deck*

- Connect the tape/cassette deck to the Tape 1 or Tape 2 sockets as shown.

A Digital Audio Tape or the audio output of a Video recorder may also be connected to any of the inputs (except Phono).

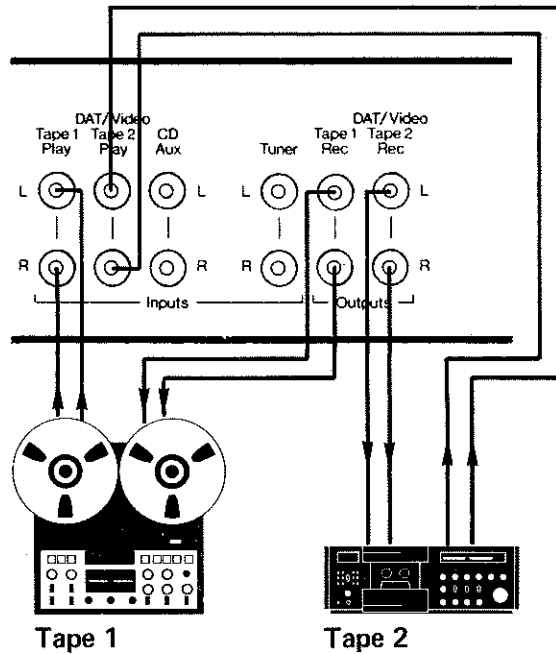

FM/AM tuner

- Connect an FM/AM tuner to the tuner input.

CD/Aux

- Connect a Compact Disc, extra tuner, cassette tape or video recorder to the CD/Aux input.

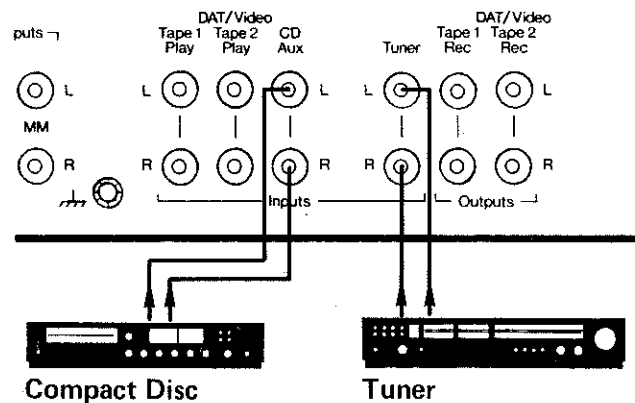

Audio Output*

Connect a power amplifier to the Audio output.

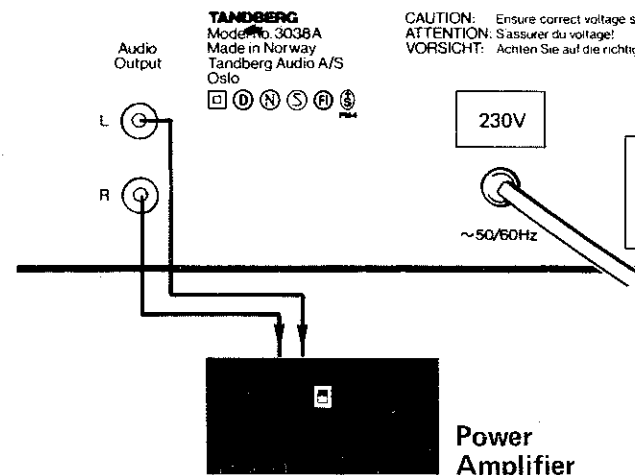

* Do not put shorting plugs into any of the outputs because the plug will short the audio signal on all the other outputs.

Switching on

Check that the control amplifier is marked with the correct voltage on the rear panel.

Plug the mains lead into the wall socket.

NOTE! The Zero Feedback stages have to stabilize before the control amplifier is ready for operation. Therefore a protection circuit will cause an approx. 12 - 15 seconds delay after switching on.

Press the Power switch to turn on the control amplifier. The control amplifier will always go to Tone Defeat and Phono mode after switching on.

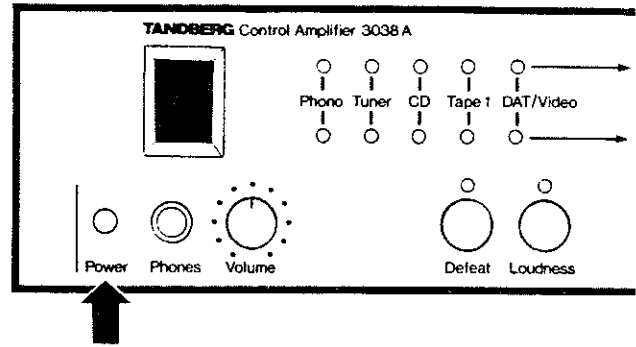

Headphones

- Connect stereo headphones with a 1/4" stereo jack to the socket marked Phones.
- Adjust the level in the headphones with the small knob marked Volume.

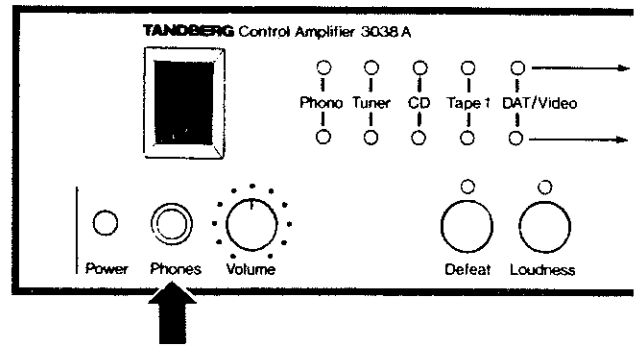

Headphone impedance
150 – 2000 ohm

Volume – Balance

- Control the output volume with the knob marked Main Volume.
- Control the volume's balance between right and left channels with the knob marked Balance.

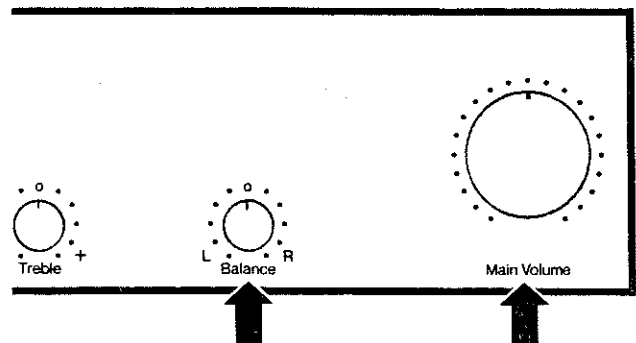

Tone Defeat

- When the Defeat LED is on, a flat frequency response is obtained regardless of the position of the tone controls.

NOTE! The Loudness is **not** affected by the position of the Defeat button.

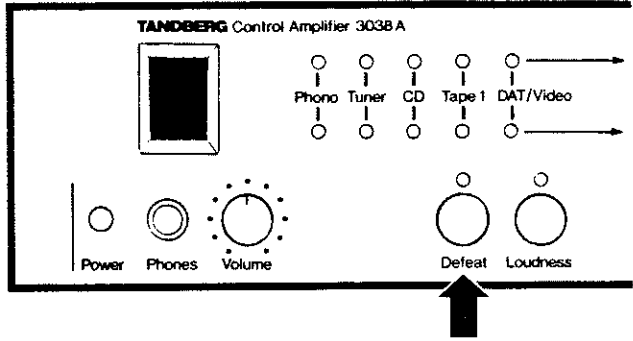

Bass – Treble

- Control the bass and treble levels with the knobs marked Bass and Treble.

NOTE! The tone controls will only work when the Defeat LED is off.

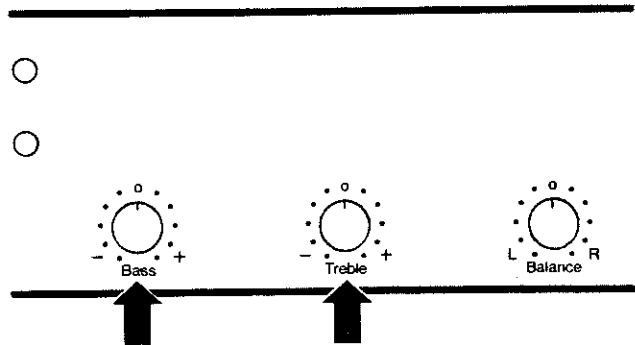

Loudness

At low volume the ear is less sensitive to low frequencies. Push the Loudness button to turn on the Loudness function. This causes low frequencies to be reproduced louder in relation to the mid. frequencies. The operation of the loudness facility is dependent on the Main Volume.

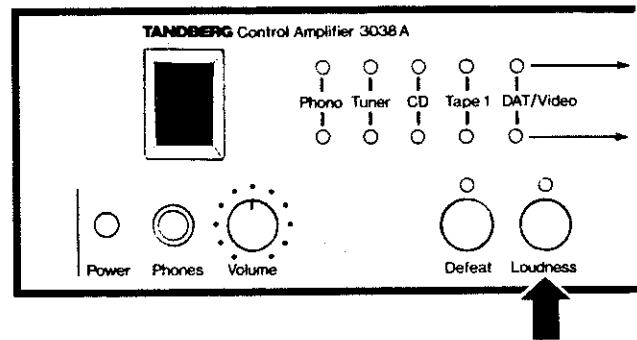

Program selector

The Program selector provides opportunities to choose between 5 program sources. You will listen to the program in the speakers depending on the position of the program selector.

Short presses on the program selector step the program source one by one from left to right and back to phono again. Keeping the selector in will automatically step the sources and when releasing, stop at the present source.

The Program selector position:

- Phono: Listen to one of the Phono inputs.
- Tuner: Listen to the Tuner input.
- CD: Listen to the CD/Aux input.
- Tape 1: Listen to the Tape 1 input.
- DAT/Video: Listen to the DAT/Video/Tape 2 input.

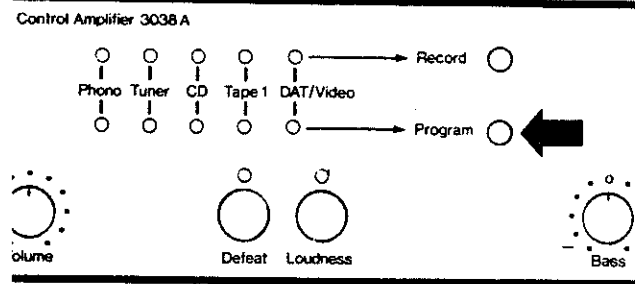

Record selector

The Record selector provides opportunities to record from 5 different program sources, regardless of which program you are listening to in the speakers.

Short presses on the record selector step the record source one by one from left to right and back to phono again. Keeping the selector in will automatically step the sources and when releasing, stop at the present source.

The Record selector position:

- Phono: Recording on both the Tape 1 and DAT/Video/Tape 2 outputs.
- Tuner: Recording on both the Tape 1 and DAT/Video/Tape 2 outputs.
- CD: Recording on both the Tape 1 and DAT/Video/Tape 2 outputs.
- Tape 1: Playback from Tape 1 and recording on the DAT/Video/Tape 2 output (copying).
- DAT/Video: Playback from DAT/Video/Tape 2 and recording on Tape 1 output (copying).

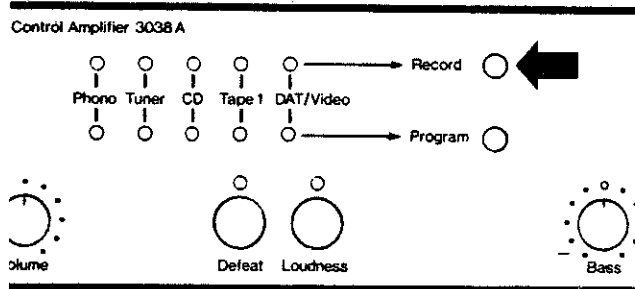

Monitoring during recording

Step the program selector to the position where the recording unit is connected. Then use the Tape/Source function on the recording unit to monitor the recording.

Remote Control operation

The Master Remote Control is designed to operate many different units.

Make sure that the batteries are correctly inserted.

NOTE! For longer periods of absence, we recommend removing the batteries. Worn out batteries should be removed immediately. Leakage from the batteries may damage the electronics.

Point the remote control at the unit during operation. Maximum range, 10 to 14 meters, is achieved when there is a clear line of sight between the remote control and the unit you wish to control.

The RC 3000 can control the following units:

- Receiver, Tuner, Cassette deck, CD player, Tape deck and preamplifier.

To control the TCA 3038A, the following functions are available from the RC 3000 control.

Main Volume

Adjusts the Main Volume up or down.

NOTE! The Main Volume can be adjusted regardless of which unit you presently are remote controlling, see figure.

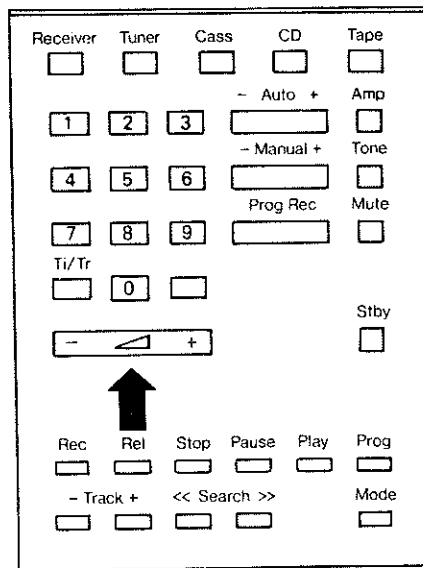

Other remote control functions

To control the other functions on the control amplifier the Amp button must be pressed first. When the Amp button is pressed you have access to all functions without pressing the system button each time. To leave the Amp control system you must press any one of the other system buttons (Tuner, Cass etc.).

Tone defeat

- Press the Tone button to switch the tone controls on or off. See LED indication on the front panel of the control amplifier.

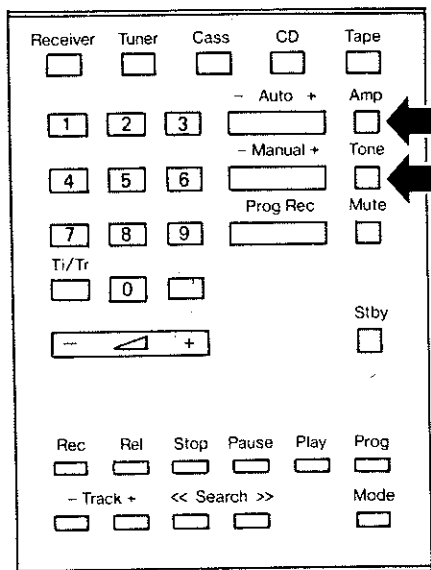

Loudness

- Press the Loud button to switch the loudness on or off. See LED indication on the front panel of the control amplifier.

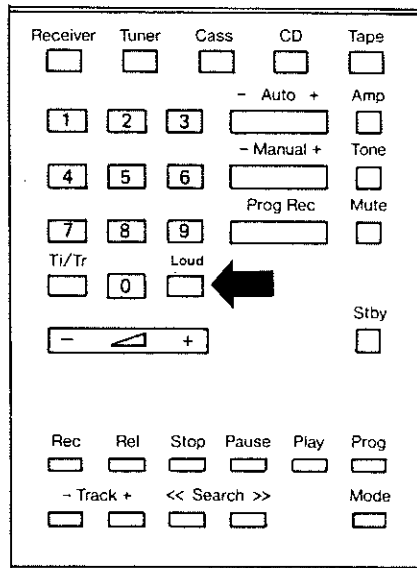

Program select

- Use short presses on the Prog Rec button on the left side to select the program source to the headphone/speakers. See LED indication on the front panel of the control amplifier.

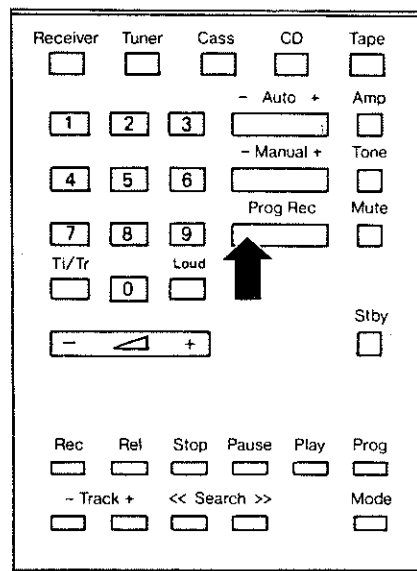

Record select

- For extra safety, the Rec button must be pressed before selecting the record source using short presses on the Prog Rec button on the right side, see figure. See LED indication on the front panel of the control amplifier.
- Press any other Amp system button than the two used to release Record select mode. (For example Loud or Tone button).

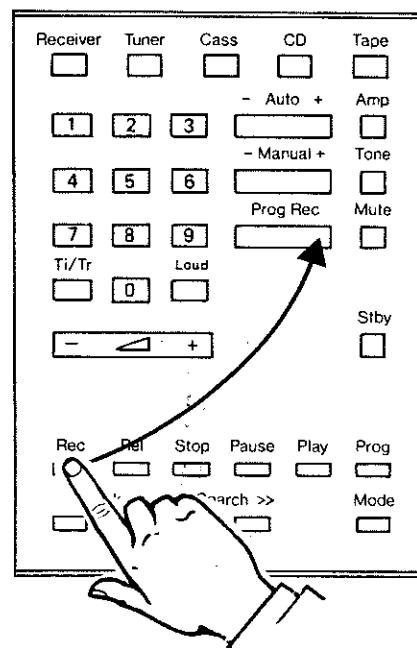

Accessories (extras)

Mounting the 19"-rack mount kit (extra)

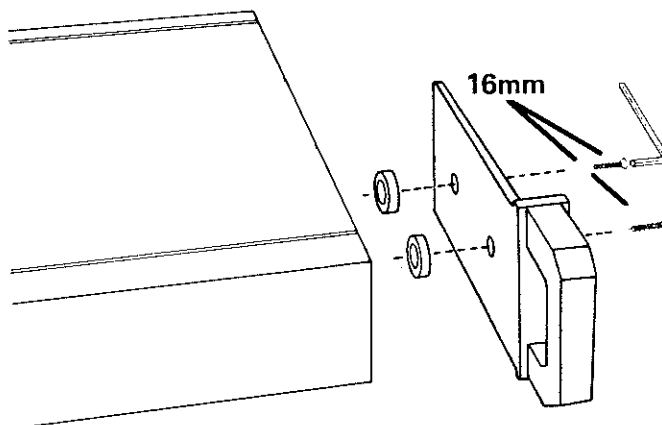

Mounting the side panels (extra)

NOTE!

When fitting extra side panels you must use the long screws (A) which are supplied.

Take care of the short screws (B) originally used to hold the side panels because you will need them if you remove the extra side panels. The long screws must not be used without the extra side panels because they can cause damage inside the control amplifier.

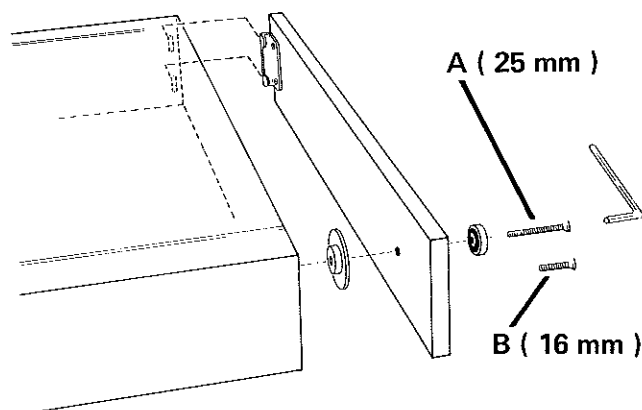

Technical Data

Tandberg Control Amplifier TCA 3038A

Power Requirements:	110 – 115 V/220 – 230 V/240 V ± 10 %, 50/60 Hz
Power consumption:	35 W max.
Dimensions:	Width 17 1/8" (43.5 cm) Depth 13 3/4" (35.0 cm) Height 3 1/2" (8.3 cm) Weight 10.7 lbs (4.85 kg)

Technical Data according to IHF-A-202, 1978

Frequency range:		
Phono MM, Phono MC:	20 – 20.000 Hz	± 0.5 dB
Tape 1, Tape 2, Tuner, CD:	20 – 20.000 Hz	+0/– 0.5 dB

Maximum Voltage Output:	
Preamp output:	5.5 V at THD = 0.05 %
Preamp output:	6 V at clipping level
Tape 1, Tape 2:	6 V
Headphone output:	10 V unloaded

Total Harmonic Distortion (20 Hz – 20.000 Hz):	
Phono MM, Phono MC:	< 0.08 %
Tape 1, Tape 2, DAT, Video, Tuner, CD:	< 0.04 %

Input Sensitivity – Ref. 0.5 V output voltage:	
Phono MM	0.9 mV
Phono MC:	60 µV
Tape 1, Tape 2, DAT, Video, Tuner, CD:	70 mV

A-weighted Signal-to-Noise ratio:	
Phono MM:	75 dB
Phono MC:	70 dB
Tape 1, Tape 2, DAT, Video, Tuner, CD:	85 dB

Maximum Input Voltage (1 kHz):	
Phono MM:	70 mV
Phono MC:	5 mV
Tape 1, Tape 2, DAT, Video, Tuner, CD:	6 V

Input impedance:	
Phono MM:	47 kohm
Phono MC:	150 ohm
Tape 1, Tape 2, DAT, Video, Tuner, CD:	min. 10 kohm

Secondary Disclosures

Output impedance:	
Preamp:	200 ohm + 22 µF in series
Headphones:	150 ohm
Headphones (min. load):	150 ohm

Tone-control response:	
Bass:	± 9 dB at 100 Hz
Treble:	± 9 dB at 10.000 Hz
Loudness:	Max. 7 dB at 50 Hz

Crosstalk (100 Hz – 10 kHz):	
Phono MM, Phono MC:	To any of the other sources > 75 dB
Tape 1, Tape 2, DAT, Video, Tuner, CD:	To any of the other sources > 75 dB

Separation (100 Hz – 10 kHz):	
Phono MM, Phono MC:	> 50 dB
Tape 1, Tape 2, DAT, Video, Tuner, CD:	> 50 dB

Transient intermodulation:	
All inputs:	Immeasurable

Other Technical Data

Frequency range:	
Tape 1, Tape 2, Tuner, CD:	1.6 – 250.000 Hz +0/– 3 dB
Phase shift (20 Hz – 20.000 Hz):	
Tape 1, Tape 2, DAT, Video, Tuner, CD:	+ 5°/– 5°

– Specifications are subject to change for further improvement without notice.

Tandberg Audio A.s
Fetveien 1, P.O. Box 49
N-2007 Kjeller, Norway

NOTE

The information in this manual is subject to improvements without notification. Additional pages may be inserted in future editions. The user is asked to excuse any omissions or errors in the present edition.

No responsibility is assumed if accidents occur while the user is following the instructions in this manual. No responsibility is assumed for defects in the unit's firmware.

We shall have no liability or responsibility to customer or any other person or entity with respect to any liability, loss or damage caused or alleged to be caused directly or indirectly by equipment sold or furnished by us, including, but not limited to, any interruption of service, loss of business or anticipatory profits or consequential damages resulting from the use or operation of the equipment or software.

