

# TANDBERG TAPE-RECORDER

MODEL 6

## *Service Manual*

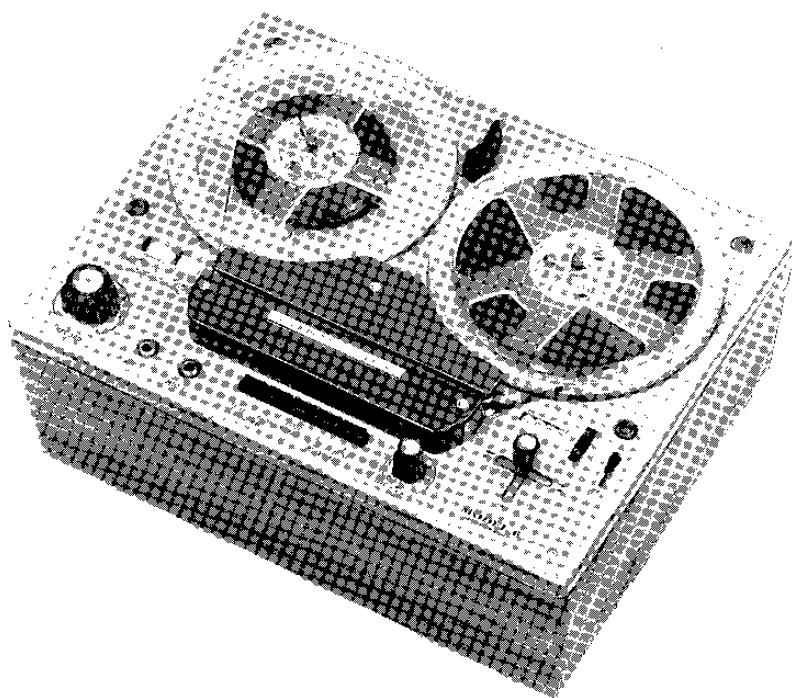

*Tandberg*  
RADIOFABRIKK

TANDBERGS RADIOFABRIKK A/S · OSLO · NORWAY

---

## CONTENTS

	Side
1) TECHNICAL DATA MODEL 6 .....	3
2) THE MECHANICAL FUNCTION .....	7
3) DETAILED DESCRIPTION OF THE MECHANISM .....	9
3.1 Operating Lever with the Micro-Switch for the Motor	
3.2 Adjustment of the Operating Lever, Stopmagnet, and Micro-Switch .....	10
3.3 The Turntables .....	11
3.4 Pulley Disc for the Take-Up Turntable .....	12
3.5 Pulley Disc for the Supply Turntable .....	13
3.6 Motor Pulley, Speed Transfer Wheel, and Speed Change .....	14
3.7 Mounting and Adjustment of Motor Pulley, Transfer Wheel, and Speed Change .....	15
3.8 Start-Stop .....	17
3.9 Adjusting Start-Stop .....	17
4) DESCRIPTION OF THE ELECTRONIC UNIT .....	18
4.1 Operating Controls .....	18
4.2 The Amplifiers .....	21
4.2.1 Preamps for Recording .....	21
4.2.2 Record Amplifier .....	22
4.2.3 Playback Amplifier .....	22
4.2.4 Cathode Follower .....	22
4.2.5 Magic Eyes .....	23
4.2.6 Erase and Bias circuitry .....	23
5) INSTRUCTIONS FOR MECHANICAL CHECK-UP.....	24
5.1 Fast Winding .....	24
5.2 Normal Forward Drive .....	26
6) INSTRUCTION FOR ELECTRICAL CHECK-UP .....	27
6.1 Adjustment of Oscillator and Suppressor Coil ....	27
6.2 Adjustment of the Heads .....	27
6.3 Adjustment of Bias .....	28
6.4 Recording Current, Measurements of Distortion ..	28
6.5 Mixing of Programs .....	29
6.6 Stereo Recording Check .....	29
6.7 Amplifier Operation .....	29
6.8 Playback Amplifier Test .....	29
6.9 Record and Playback Curves .....	29
6.10 Speed Check .....	30
6.11 Microphone and Erase Check .....	30
6.12 Sound on Sound .....	30
6.13 Fuses .....	30

## 1. TECHNICAL DATA MODEL 6.

Dimensions:	Teak cabinet 16" long, 12 wide, 6 high.
Weight:	Instrument alone 25 lbs. with carrying case 30 lbs.
Line Voltage:	110 — 125 — 145 — 200 — 220 — 245 volts.
Frequency:	50 or 60 cps.
Power Input:	65 watts.
Tubes:	6 ECC83 (7025), 3 ECC82 (12AU7), 2 EAM86.
Rectifiers:	Selenium Rectifier 75 mA, 250 volts (B250,C75) and low voltage Selenium Rectifier (B30, C1000).
Recording Tape:	Red Oxide Tape. Maximum reel diameter 7".
Motor:	Hysteresis Synchronous Motor, system Papst.
Tape Speeds:	7 ½, 3 ¾, and 1 ⅞ inches per second. The recording amplifiers as well as both playback amplifiers are individually equalized, so that for all 3 speeds the amplifiers will be compensated to conform the NARTB standard. The Recorder can therefore play back stereophonic tapes recorded at either 7 ½, 3 ¾, or 1 ⅞ ips.
Speed Accuracy:	Relative accuracy, repeated playback: ± .2% or ± 3.6 seconds in 30 minutes. Absolute speed tolerance: ± 1%.
Heads:	Three heads: for erase, record, and playback respectively. 1) Quadruple erase head wired for single as well as double track erasing. 2) Quadruple recording head especially designed for maximum frequency response and minimum distortion and noise. Airgap 0.013 mm (0.0003"). 3) Quadruple playback heads designed for maximum sensitivity and frequency response and for minimum noise. Airgap 0.003 mm (0.00012"). Note: Separate heads are used for recording and playback to obtain optimum performance.
Playing Time:	Four track recording on 1200 ft. of tape gives the following playing times:  Tape speed 7 ½ ips: Stereo 2 x 32 min. Monaur 4 x 32 min. Tape speed 3 ¾ ips: Stereo 2 x 64 min. Monaur 4 x 64 min. Tape speed 1 ⅞ ips: Stereo 2 x 128 min. Monaur 4 x 128 min.
Path of Tape:	The tape moves from left to right. The heads are positioned with the gaps towards the front. Recording takes place on track 1—4 or;and track 3—2.
Fast Forward- and Rewinding:	Takes approx. 2 min. in either direction for 1200 ft. of tape without wear of the heads.

Automatic Stop:	Possible on tape which has the necessary metal coating at beginning and end of the reel.
Remote start/stop:	Contact provided for connection to foot control switch. Operating with the start/stop button depressed.
Frequency Response:	7 1/2 ips 30—20 000 cps ( $\pm$ 2 dB 40—16 000 cps) 3 3/4 ips 30—14 000 cps ( $\pm$ 2 dB 40—10 000 cps) 1 7/8 ips 50— 7 000 cps ( $\pm$ 2 dB 55— 5 000 cps)
Distortion and Noise Level:	Distortion from the record amplifiers at max. recording level below 0.5 %. The tape recorded to maximum level by a 400 cps signal will give less than 3 % distortion when played back. A recording 10 dB below the maximum level results in less than 0.5 % distortion of the 400 cps signal when played back. The noise level is 53 dB below the signal level when the tape is driven to 3 % distortion. 55 dB below the signal level when the tape is driven to 5 % distortion.
Crosstalk:	400 c/s better than 60 dB. 50 c/s better than 30 dB.
Wow:	Better than 0.15 % at 7 1/2 ips tape speed. Better than 0.2 % at 3 3/4 ips tape speed. Better than 0.3 % at 1 7/8 ips tape speed. Wow is defined as the r.m.s. value of frequency deviation to one side of the signal frequency when a constant signal frequency is recorded and played back. The peak to peak value is 2.8 times larger.
Microphone:	Crystal mike shock-insulated for rugged use. Frequency response — 20 to 13 000 cps $\pm$ 3 dB.
Output:	A tape recorded to 3 % distortion will give 1.5 volts out. The distortion from the playback amplifier is below 0.2 % when the load impedance is 10 Kohms or more, increasing to 2 % distortion at 2 000 ohms. Minimum load impedance without reducing the output voltage and keeping the distortion less than max. permissible value (2 %) 2 000 ohms.
Erase and Bias Frequency:	78 $\pm$ 2 kcps. Even harmonic distortion in high frequency bias current < 0.5 %.
Recording level Indicator:	The electronic magic eye maintains its sensitivity corresponding to recording current up to 15 000 cycles (with tube rectifier and damped backward movement). Electronic eye tube range 20 dB, plus overload. The magic eye is regulated to max. recording level when the recording gives approx. 3 % distortion on the tape.
Counter:	4 digit counter shows number of revolutions on the take up turntable.
Controls:	Record Level Control: Double potentiometer with a double knob which makes it possible to regulate the two record amplifiers simultaneously or individually. Playback Volume Control: Double potentiometer with a double knob for adjustment of output signal. Speed Selector: 7 1/2 ips, 3 3/4 ips and 1 7/8 ips. Lever Control: For Start, Stop, Forward, and Rewind. Sound on Sound Monitoring Switch. Push Button Center: 2 record buttons, 2 playback buttons, and 1 start-stop button. The functions of the buttons are:

1) Record Buttons (1 and 2): Record button Channel 1 connects the record amplifiers to the upper record head, energizes the corresponding magic eye, and connects the bias and erasing oscillator to the upper track record and erase heads. Record button Channel 2 performs the same function for the lower heads.

When only one record button is depressed, the outputs of the two preamps are connected together, i.e. the two programs mixed and sent through the record amp. to the record head corresponding to the record button depressed.

The input signal to the record head is mixed with the proper amount of high frequency bias.

The inputs marked channel 1 is adjusted by the upper knob and the inputs marked channel 2 by the lower knob. In both record positions the recorder is a two channel mixer. When both record buttons are depressed each input is connected to its respective head.

There is a safety interlock between the two record buttons and the operating lever. It is possible only to operate the record buttons in the neutral position of the lever. The record buttons are released when the operating lever is pushed to neutral position.

2) Start-Stop Button: In the inoperated position (stop) the stop magnet is energized and the high voltage to the oscillator is broken. Depressing the button breaks the current through the stop magnet and the recorder starts instantly. The high voltage is connected to the oscillator, if one or both of the record buttons are depressed.

3) Playback Buttons (1 and 2): The playback heads are permanently connected to the playback amplifiers. The playback buttons in operated position connect the cathode followers to the playback amplifiers. In the inoperated position the playback buttons connect the cathode follower to the record preamplifier. In this way there is a possibility to listen to the program before and after recording, A-B-test. This function is however influenced by the position of the S-on-S switch and the record buttons.

4) Sound and Sound Switch.

This switch has three positions, A-B-test, Normal, and S-on-S. (The first series TB6 produced lacks the Normal position).

a) Normal Position.

In this position it is possible to record and play back mono and stereo. In mono operation the two input channels can be mixed and the same playback program can be fed to both output channels. A-B-test is not possible in this position.

b) A-B-test Position.

The cathode followers are connected to the playback amplifiers, when the playback buttons are depressed.

When the playback buttons are released the recorder acts as a pre-amplifier giving the following possibilities:

Stereo preamp, or mono preamp for both channels. One mono program can go out over both channels when the recorder is engaged in the actual record position.

c) Sound-on-Sound switch in «S-on-S».

For sound-on-sound monitoring only one playback button is depressed. By switching the S-on-S switch to «S-on-S» the connection between the two cathode followers is broken. The playback amplifier which corresponds to the depressed button acts still as a playback amplifier for the corresponding playback head. The other cathode follower input is connected to the corresponding record preamp output. (Note that when one of the record buttons is depressed, the connection between the two recording amplifiers still exists). The Sound-on-Sound Switch is introduced to improve the flexibility when recording sound-on-sound. The procedure will be as follows — for a master recording on upper track: Depress the playback button no. 1. Then the master progr. is reproduced across the cathode follower 1. Connect the cathode follower 1 output to high level input 1 with an external wire. Put the microphone in mic. 2. Depress record button 2 and start the recorder by operating the start-stop button. The following will happen: The master progr. will be recorded on lower track, the master program controlled by the upper potentiometer knob, and the mic. input will simultaneously be recorded on the lower track controlled by the lower potentiometer knob. It is then possible to make an A-test on the total program recorded at lower track across the cathode follower output 2. By depressing playback button no. 2, a B-test will be made of the same program.

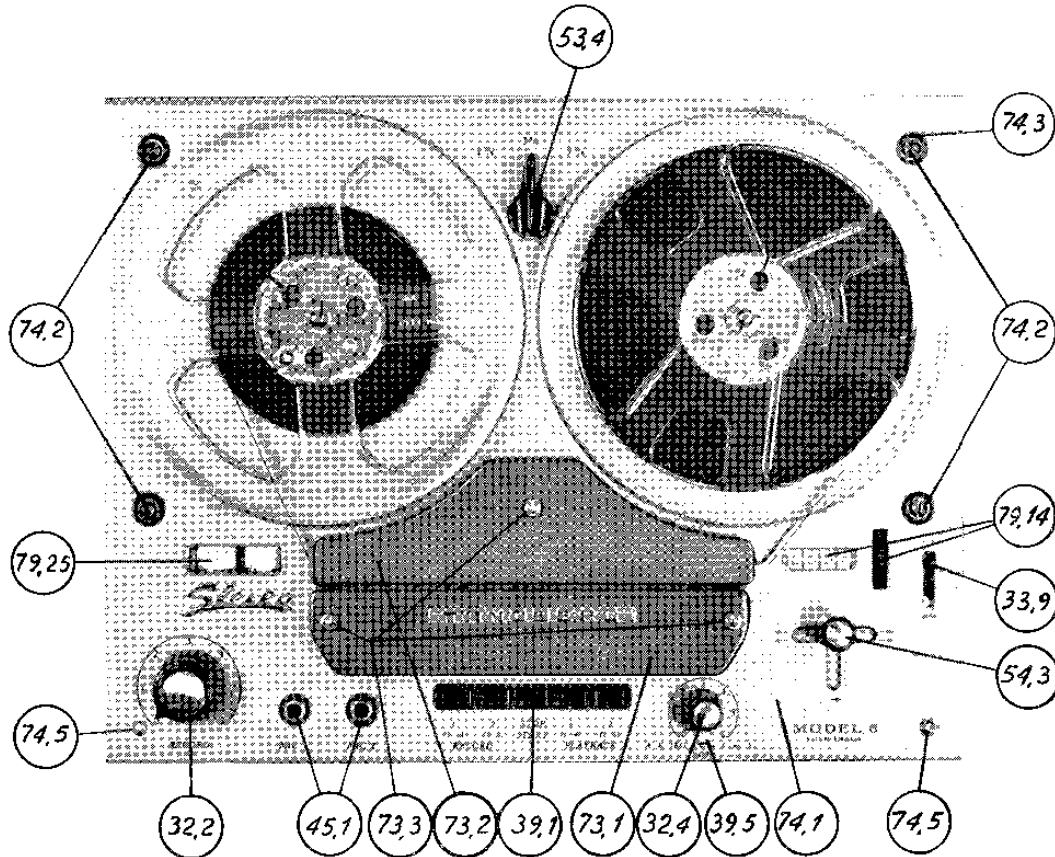

Fig. 1. Top View

## 2. THE MECHANICAL FUNCTION

The driving mechanism has three main functions, namely Normal Forward Drive, Fast Forward Winding, and Fast Reverse Winding. The operating lever has one neutral or stop position and three operation positions which are as follows: Normal Forward Drive when the operating lever is pulled toward the front, Fast Forward and Reverse Winding when the operating lever is in the position to the right or to the left of the neutral position respectively.

Fig. 1 is a top view of the tape recorder. The operating lever (54.2) is in neutral position. The speed selector shaft (53.3) with its three positions for 7 1/2 ips, 3 3/4 ips, and 1 7/8 ips is located between the turntables towards the rear. Speed selection is accomplished by turning the knob (53.4) to the marked position for the wanted speed. The path of the tape is: The quadruple erase head (15.3), the quadruple recording head (15.1), and the quadruple playback head (15.2). Recording follows the quadruple track standard (see fig. 2). The double track heads make contact with tracks 1 and 3. By interchanging the reels, tracks 4 and 2 will be under the heads (fig. 2).

The top plate (74.1) can be removed without taking the unit out of the mounting cabinet, the four screws marked (4 x 74.2) and the operating knobs the speed selector knob (53.4), the operating lever knob (54.3), the volume controls (32.2) and (32.4), and the trim covers (73.1) and (73.2), have to be removed in before hand. (Do not loosen the turbax washers that insulate the microphone jacks from the top cover, and make sure that washers and screws are replaced in their proper position when reassembling). Note: On the first recorders of Model 6 produced (2 000 recorders), the Sound-on-Sound Switch was located underneath the recorder and was reached by a screwdriver through a hole in the bottom.

In fig. 3 the top cover is removed and a part of the mechanism is seen. The motor pulley (62.1) is seen in the middle. It has two grooves for coupling the belt (62.2) to the two pulley discs (61.1 and 61.2) located underneath the turntables. Detailed descriptions of the pulley discs are given later.

The pulley discs are permanently coupled to the motor pulley (62.1) by means of the rubber drive belt (62.2) and start as soon as the motor is switched on.

In addition to the two V-shaped grooves on the motor pulley there are three peripheral tracks of unequal diameters. These tracks in conjunction with the speed transfer wheel (53.1) give the correct speeds to the flywheel (66.1) and capstan (66.2), and consequently to the recording tape at either 7 1/2, 3 3/4, or 1 7/8 ips. Operating the speed selector disengages the speed transfer wheel by turning its mounting arm (53.3) which raises or lowers the arm to switch the speed transfer wheel from one track to the other. The cam disc (59.17), see fig. 15 provides for three accurate height positions for the transfer wheel mounting arm corresponding to 7 1/2, 3 3/4, and 1 7/8 ips. Two springs (53.5) attached to the transfer wheel arm keep the wheel engaged. In all positions except Normal Forward Drive the transfer wheel is kept disengaged by the lifting arm (59.25). Details concerning the speed transfer wheel are discussed later.

The whole mechanical operation is actuated by means of the operating lever (54.1). In the neutral position the motor is turned off. Any other position of the operating lever switches the motor on and starts the pulley discs.

The automatic stop functions only when tapes having metal coating at the ends are used. This metal coating will make contact between the right tape guide (79.4) and the contact (79.5) (Fig. 3). The stop magnet mounted on the ope-

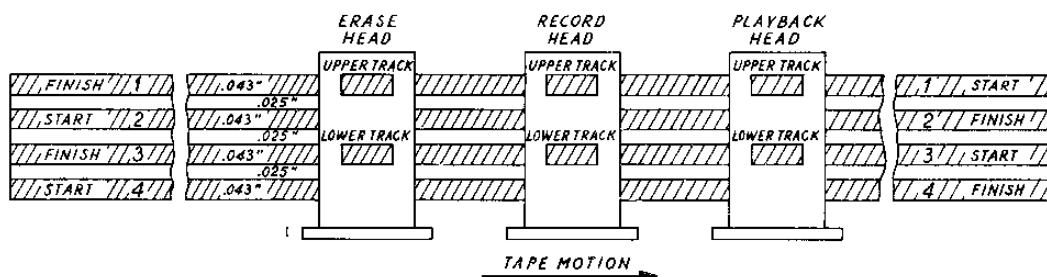

Fig. 2. Quadruple Track Standard.

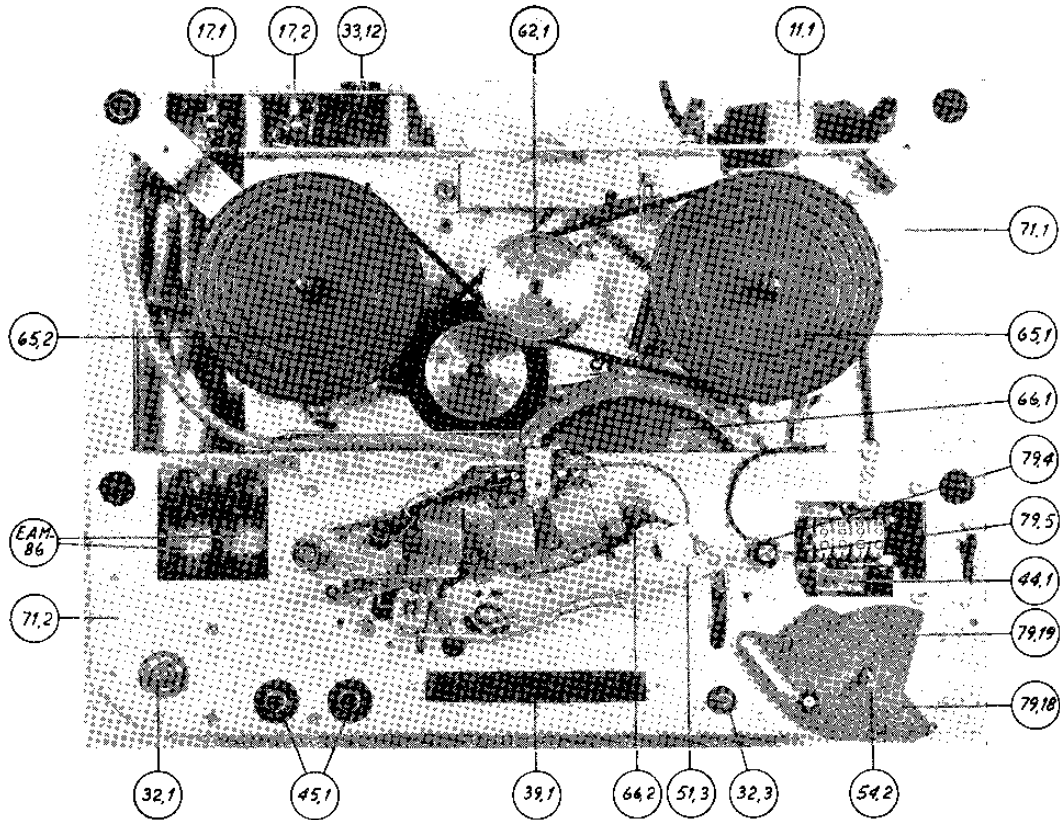

Fig. 3. Top View, Plate Removed.

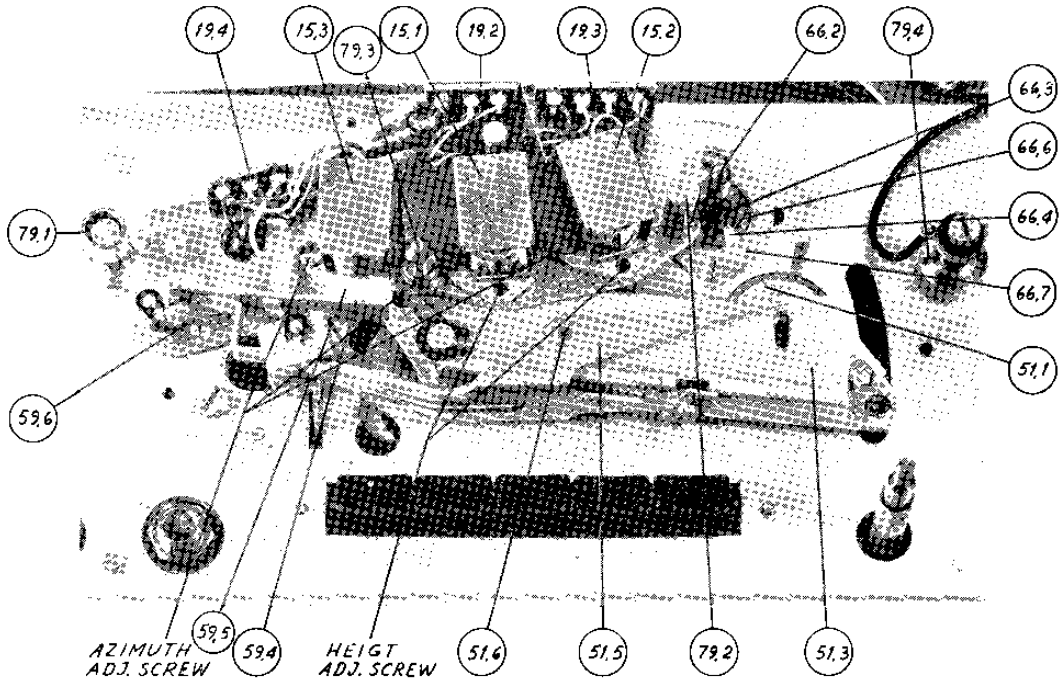

Fig. 4. Heads and Pressure Wheel Assembly



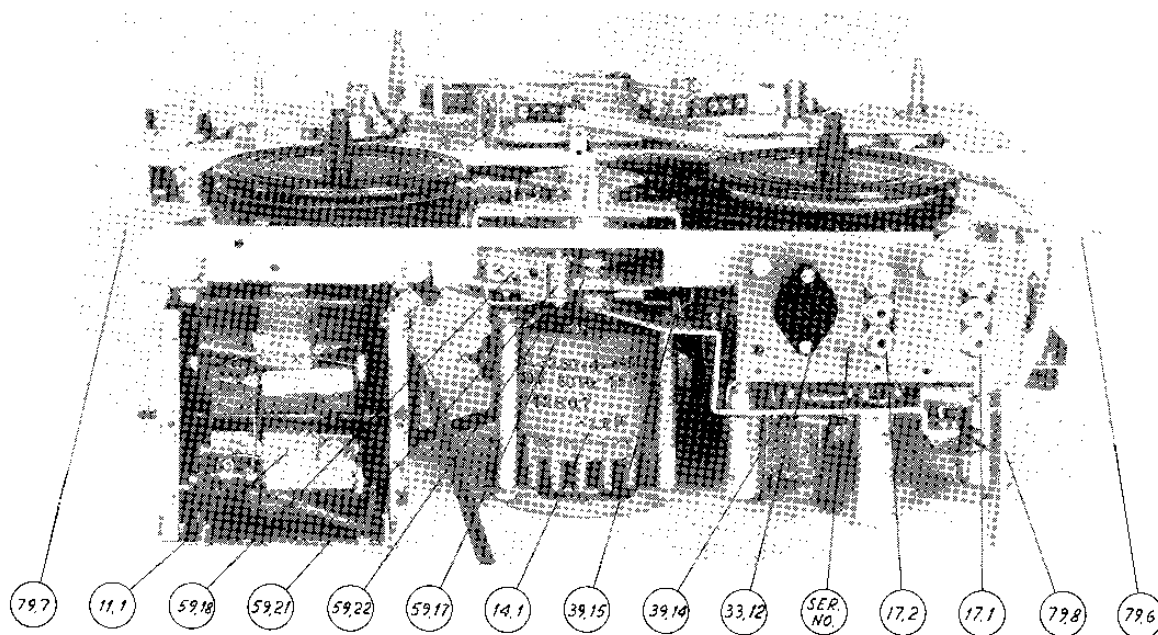

Fig. 5. Rear View

rating lever bracket is actuated and breaks the motor current by means of the switch otherwise operated by the operating lever.

The start-stop button (39.1) operates a relay (33.1), fig. 18, which releases the pressure wheel (51.1) from the capstan (66.2). In stop position (button released) the relay is activated and the tape is running free between the capstan and the pressure wheel. In start position (button depressed) the current through the relay is broken, and the pressure wheel (51.1) presses the tape against the capstan (66.2) with a pressure of 750—1 000 grams. The mechanical movement of the start-stop relay is transferred to the pressure wheel (51.1) by the pressure wheel lever (51.5). The pressure wheel bracket (51.3) operates the Muting Switch (39.6), located under the mounting plate.

### 3. DETAILED DESCRIPTION AND INSTRUCTIONS FOR ADJUSTING THE MECHANISM

#### 3.1 Operating Lever with the Micro-Switch for the Motor.

When the operating lever (54.1) is in the position for normal forward drive and the start-stop button (39.1) depressed, the pressure wheel (51.1) is pressed against the capstan (66.2). Attached to

the pressure wheel assembly (51.3) is a roller (51.9) that slides along the contour of an eccentric segment (59.1), fig. 36, which is the connecting link between the operating lever (54.1) and the pressure wheel assembly (51.3). If the operating lever (54.1) is pulled all the way down, the tape starts gradually at normal speed. The turntables (65.1 and 65.2) are put into motion by the operating lever in the following way: the rotating pulley discs (61.1 and 61.2) are raised or lowered depending upon the position of the trip bar (52.1). The pulley discs (61.1 and 61.2) engage or disengage the turntables (65.1 and 65.2). Detailed description of the functioning and assembly is found under the next heading. In Normal Forward Drive position the take-up turntable (65.1) is coupled to its pulley disc (61.1) with sufficient take-up friction, while the supply turntable (65.2) runs only with bearing friction. The pulley disc (61.1) engages the take-up turntable (65.1) with max. friction in the position for Fast Forward Winding, while the supply turntable (65.2) runs with just bearing friction. In the position for Fast Reverse Winding the frictions described above are interchanged.

In figs. 6 and 7 is a close-up view of the operating lever assembly. The actuator of the micro-

switch is located underneath the actuator lever for the microswitch (33.7) which keeps the micro-switch (33.5) in the «off» position while the operating lever (54.2) is in the neutral position as shown. The micro-switch used has very little over-travel and a preset plate spring for the micro-switch (33.6) is inserted between the actuator lever (33.7) and the operating knob on the switch to allow a larger movement of the lever (33.7) making adjustments easier. If the operating lever (54.2) is set to any position other than neutral, the end of the operating lever (54.2) slides off the sloping edges of the actuator lever (33.7) and causes the micro-switch (33.5) to switch to the «on» position.

To avoid electrical switching noise in the amplifier a noise suppressor circuit, C13—0.1  $\mu$ F and R17—51 ohms, is mounted on the bakelite strip (54.1).

Figs. 6 and 7 also show the stop magnet assembly. When the magnet is actuated (through the metal coating on the tape) the conical end of the stop magnet armature (33.3) will press the actuator lever (33.7) down and break the motor current. Pushing the operating lever (54.2) to

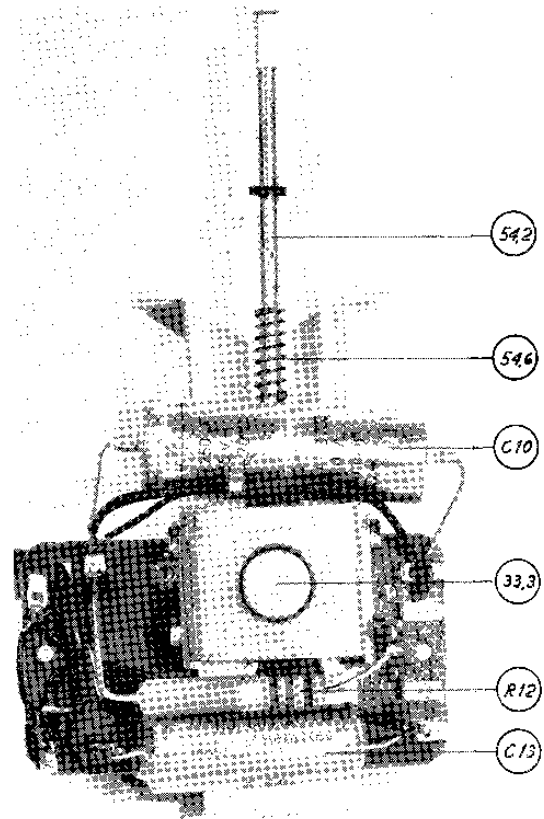

Fig. 7. Operating Lever Assembly

neutral position moves the armature back to neutral.

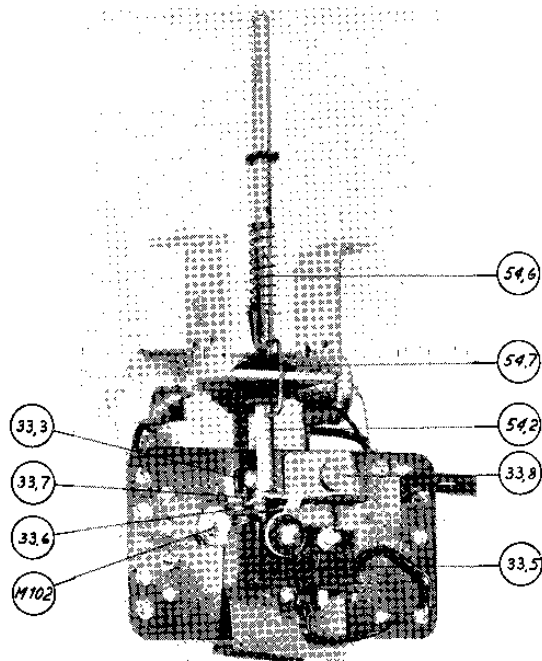

Fig. 6. Operating Lever Assembly

### 3.2 Adjustment of the Operating Lever, Stop Magnet, and Micro-Switch.

The switching of the motor current takes place when the operating lever (54.2) is about half way between the NEUTRAL and any other position. Adjustment of the operating point when going to the fast winding position is made by loosening the two screws (2 x M102) (fig. 6) and displacing the bakelite mounting plate for micro-switch sideways until the actuator lever for the micro-switch (33.7) becomes aligned with the tip of the operating lever (54.2). Then the bakelite mounting plate is moved upwards until switching takes place at the proper position. The operating point, when moving the operating lever (54.2) towards record or playback position, is adjusted by bending the tip of the actuator lever (33.7).

After the bakelite mounting plate with the micro-switch (33.5) is fastened in its proper position with respect to the operating lever (54.2), the stop magnet assembly is adjusted. The location of the armature (33.3) is determined by the hole in the rear plate for the stop magnet. The holes for the screws holding this plate are oblong, allowing necessary movement. When the armature (33.3) is correctly adjusted the cylindrical part of the brass end of the armature (33.3) should enter the actuator lever (33.7) in operated position. In this position the actuator lever (33.7) has just operated the micro-switch (33.5). The actuator lever (33.7) must not be pressed so far down that the plate spring for the micro-switch (33.6) is bent, else the power required to operate the relay is too large and hence the automatic stop will not work correctly.

### 3.3 The Turntables.

The clutch assembly of the two turntables is designed as shown in fig. 8 in exploded view. The whole assembly is built around the housing for the turntable bearing (65.3). The housing is riveted to the lower mounting plate (71.1). Assembling is done in the following manner: Place the compression spring (61.3 or 61.4) over the housing (65.3), one end going into one of the holes in the lower mounting plate (71.1). Next, place the pulley disc (61.1 or 61.2) with its cartridge (61.5) over the housing (65.3) while guiding the compression spring (61.3 or 61.4) into its cylindrical groove in the cartridge (61.5). The tags on the cartridge (61.5) should lie on a line perpendicular to the front of the mounting plate (71.1). Press down on the pulley disc (61.1) until the tags have passed through the notches in the clutch levers (59.7 and 59.8 or 59.9). Then turn the cartridge (61.5) 90 degrees (clockwise for the take-up clutch assembly and counter-clockwise for the supply clutch assembly) so that the two tags are locked in position by the catches on the clutch lever (59.7 or 59.9) and exert a slight pressure on one of the catches. The pressure prevents chattering during operation. Now, the flange for the housing (72.1) with its turbax washer can be pushed into the upper end of the housing (65.3). The turntable shaft goes into its bearing and the felt ring underneath the turntable (61.1 or 61.2) rests on the pulley disc (65.1 or 65.2).

The retaining ring (M324) on the supply pulley cartridge prevents the supply clutch lever from slipping the tags on the cartridge when the supply pulley disc is pressed down. The retaining ring has to be removed before the supply clutch assembly can be disassembled.

Exerting pressure on the turntable (65.1 or 65.2) causes the pulley disc (61.1 or 61.2) to move downwards. The turntable is stopped by the flange (72.1) mounted in the housing. The operating lever (54.1) pushed to Fast Reverse position lowers the pulley disc (61.1) so that the take-up turntable (65.1) rests on the flange (72.1). The

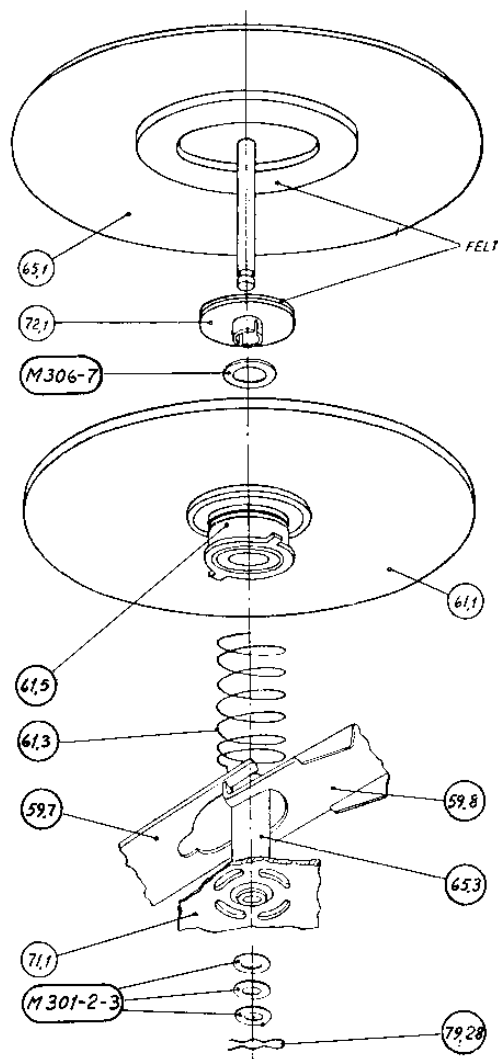

Fig. 8. Clutch Assembly of Take-Up Turntable

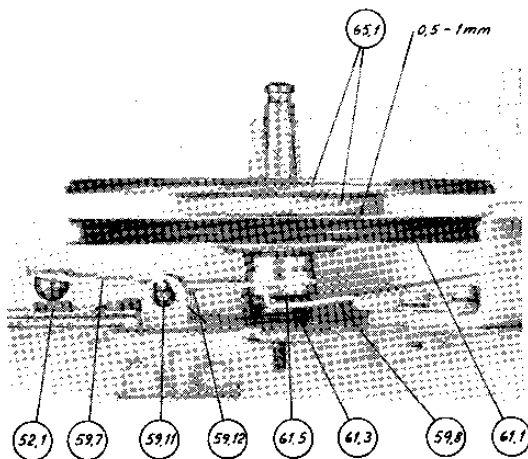

Fig. 9. Take-Up Turntable. Fast Reverse Position

same happens to the supply turntable (65.2) in Fast Forward position. A suitable number of turbax spacers are put on the shaft of the turntable before the lock spring is put into position. An axial displacement of about 0.1 mm (0.04") should still be possible.

Before any further adjustment can take place, correct positions of the tape reels and shafts must be ascertained. With the top cover (74.1) in place, see that the turntables (65.1 and 65.2) lie in the same plane in a direction parallel to the front by placing a reel on the turntables. Also uneven heights are easily detected in this way. Small corrections can be done by giving the housing for the turntable bearing a twist. Tool no. 1 and no. 3 (Fig. 32).

Adjustment in a direction perpendicular to the front is done by checking that the tape leaves or enters the tape reel without touching the flanges of the tape reel. With an empty tape reel on the turntable sight across and see that the track in the tape guides (79.1 and 79.4) lies equidistant from the flanges of the tape reel. Tool no. 2 (Fig. 32). (This check should be done with the operating lever (54.1) in neutral position). Corrections are done in two different ways: By twisting the housing for the turntable bearing a little towards or away from the tape guides (79.1 and 79.4). (Tool no. 3 Fig. 32), or by adding or subtracting turbax washers underneath the flange (72.1) in the housing for the turntable bearing, (see fig. 8). Which procedure to follow depends upon how the tape runs relative to the top rocer and the

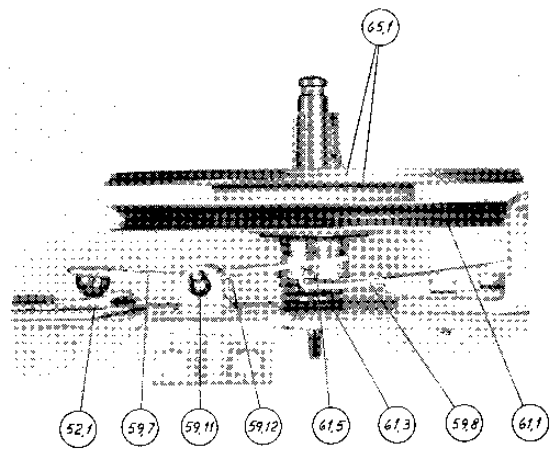

Fig. 10. Take-Up Turntable. Normal Forward Drive

reel. Secure sufficient clearance between the tape reel and the top cover (74.1).

### 3.4 Pulley Disc for the Take-Up Turntable.

Operating lever (54.1) in Fast Reverse Position (fig. 9): The upper clutch lever for the take-up pulley disc (59.7) is adjusted in this position. The trip bar (52.1) is now in such a position that the steel ball on which the clutch lever (59.7) rests is in its highest position. The other end of the upper clutch lever (59.7) pushes down the tags on the cartridge (61.5) and lowers the pulley disc (61.1) together with the lower clutch lever for the take-up pulley disc (59.8). In this position there must be about 0.5 mm (0.02") clearance between the felt ring and the pulley disc (61.1). The clearance can be adjusted by bending the clutch lever (59.7) slightly, at all times make sure that the clutch lever (59.7) touches the two tags on the cartridge (61.5) simultaneously. Tool no. 4 (Fig. 32).

The operating lever (54.1) in the Normal Forward Drive position (fig. 10). In this position the take-up turntable (65.1) must be given a suitable friction torque by the pulley disc (61.1) to wind the tape during recording or playback. The friction torque should be from 20 to 25 grams (1 oz.) acting on an arm of 8 cm (3 1/2") or about 200 gram-centimeters (3 oz.-in.). From fig. 8 it may be seen that the tags on the cartridge (61.5) are midway between the upper (59.6) and lower (59.8) clutch levers. The upper clutch lever (59.7) is positioned with its steel ball in the middle posi-

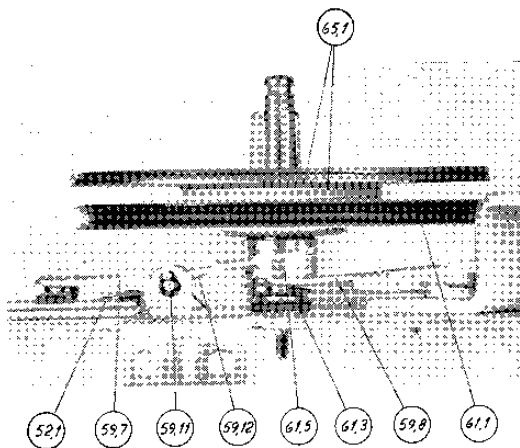

Fig. 11. Take-Up Turntable, Fast Forward and Neutral Positions

tion which releases the pressure from the lower clutch lever (59.8) on the tags. The pulley disc (61.1) is pressed against the felt ring on the turntable (65.1) with the compressive force of the helical compression spring for the take-up pulley disc (61.2) only. The compressive force of the spring (61.3) must be adjusted to give the friction torque mentioned above. Because the felt gradually wears down the clearance between the tags on the cartridge (61.5) and the upper clutch lever (59.7) should be about 0.5 to 1 mm (0.02" to 0.04"). To guard against unwanted upward pressure by the lower clutch lever (59.9), there should be about 0.5 mm (0.02") clearance underneath the tag. Operating lever in the Fast Forward and Neutral positions (fig. 11): The opera-

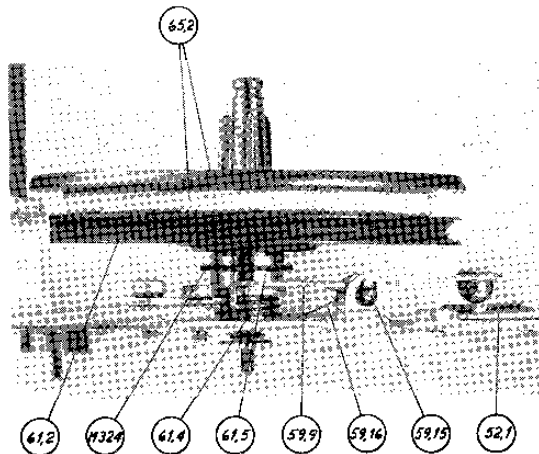

Fig. 12. Supply Turntable, Fast Forward and Normal Forward Drive Positions

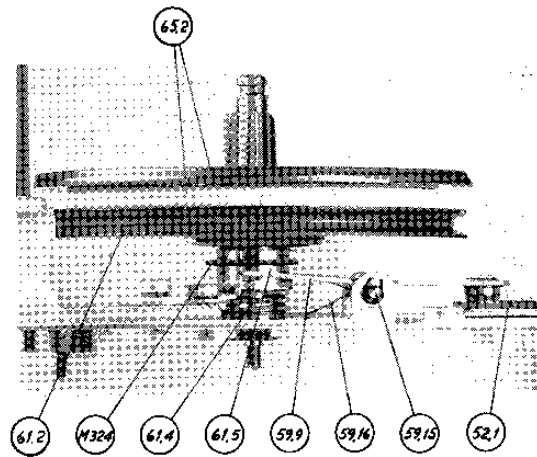

Fig. 13. Supply Turntable, Fast Reserve and Neutral Positions

ting lever (54.1) is now in such a position that the steel ball on which the clutch lever (59.7) rests is in its lowest possible position, i.e. the other end of the lever (59.7) is as high as possible. The spacing between the upper clutch lever (59.7) and the catches on the lower lever (59.8) should be about 0.5 mm (0.02"). The lower clutch lever (59.8) exerts pressure on the tags of the cartridge (61.5) and engages the clutch by means of a stiff spring (59.14). In Fast Forward position it is of importance to ascertain a high friction torque. This is accomplished by means of a helical spring (61.3) and an additional spring underneath the lower clutch (59.14). The friction torque should be about 50 grams (2 oz.) acting on an arm of 8 cm (3") or the equivalent of 400 gram-centimeters (5-6 oz.-in.). The friction torque is mainly supplied by the lower clutch lever (59.8) and the spring pressure must be adjusted if the torque is too low.

### 3.5 Pulley Disc for the Supply Turntable.

Operating lever in Fast Forward and Normal Forward Drive positions (fig. 12): The pulley disc (61.2) is in the same position for Fast Forward and Normal Forward drive. The steel ball on the clutch lever for supply pulley disc (59.9) is at its highest position on the trip bar (52.1). The clutch lever (59.9) acts on the tags of the cartridge (61.5) and disengages the clutch. Felt-to-pulley disc clearance should be 0.5 to 1 mm (0.02" to 0.04"). Clearance is adjusted by bending the clutch lever (59.9). Tool no. 4 (Fig. 32).

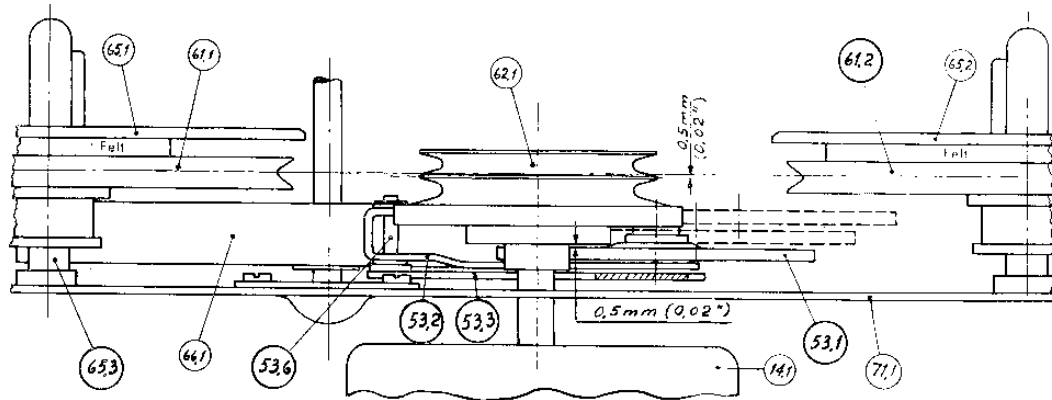

Fig. 14. Driving Mechanism

Operating lever in Fast Reverse and Neutral positions (fig. 13): The steel ball is in its lowest position and the clutch lever (59.9) raised to obtain clearance between the lever (59.9) and the tags on the cartridge (61.5). The helical compression spring for the supply pulley disc (61.4) has considerably higher tension than the corresponding one (61.3) in the right hand clutch assembly and supplies all the friction torque itself. The friction torque should be 50 grams (2 oz.) acting on 8 cm (3") or about 400 gram-centimeters (5-6 oz.-in.).

### 3.6 Motor Pulley, Speed Transfer Wheel, and Speed Change.

A side view of the driving mechanism with the transfer wheel (53.1) in the  $1\frac{7}{8}$  ips position is shown in fig. 14. The speed transfer wheel (53.1) has three different positions, corresponding to the three speeds. In the two lowest positions ( $1\frac{7}{8}$  and  $3\frac{3}{4}$  ips) the spacing between the upper edge of the speed transfer wheel (53.1) and the motor pulley (62.1) shall be 0.5 mm (0.02"). In the upper position ( $7\frac{1}{2}$  ips) the upper edge of the speed transfer wheel (53.1) should be below the upper edge of the flywheel (66.1).

The speed change mechanism is shown in fig. 15. The key part is the cam disc (59.17) which determines the position of the transfer wheel arm (53.3) and also takes care of the lifting. The manner of operation is as follows: In  $1\frac{7}{8}$  ips position the transfer wheel arm (53.3) is pressed against the lowest level of the cam disc (59.17). When turning the speed selector knob (53.4) towards  $3\frac{3}{4}$  ips position, the transfer wheel (53.1) is lifted away from the motor pulley (62.1) and the flywheel (66.1) by the cam disc arm (59.18), which rests

with a little roller (59.21) against the curvature of the cam disc (59.7). The transfer wheel (53.1) is lifted so far that it can easily be lifted to the track for  $3\frac{3}{4}$  ips. The lifting is done by the slope of the cam disc (59.17) which is pushed underneath the transfer wheel arm (53.3), (see figs. 14, 15, and 16).

The two extension springs (53.5) which secure the contact between the motor pulley (62.1), the transfer wheel (53.1), and the flywheel (66.1) are fastened approx.  $\frac{1}{2}$  inch from the rotating centre of the transfer wheel holder (53.2) to give the transfer wheel holder (53.2) a rotation moment that presses the transfer wheel (53.1) against the flywheel (66.1) when it is lifted out of contact. The rotation moment secures the transfer wheel (53.1) from being jammed under the motor pulley (62.1) during the vertical lifting. When the speed selector knob (53.4) has reached the  $3\frac{3}{4}$  position, the cam disc arm (59.18) will move backwards again and allow the transfer wheel (53.1) to make contact with the motor pulley (62.1) and the flywheel (66.1), now at the track for  $3\frac{3}{4}$  ips on the motor pulley (62.1). The backward movement is obtained at the moment the roller (59.21) slips into the marking slot for  $3\frac{3}{4}$  ips. When turning the speed change knob (53.4) further to the  $7\frac{1}{2}$  ips position, the transfer wheel (53.1) will in a similar way be lifted to make contact with the  $7\frac{1}{2}$  ips track on the motor pulley (62.1). With the operating lever (54.1) in Neutral and in Fast Winding positions the transfer wheel (53.1) is lifted away from the motor pulley (62.1) by means of the lifting arm (59.25).

The flywheel brake spring (66.9) is mounted on the linkage arm (59.25) to brake the flywheel in all positions except Normal Forward Drive. The

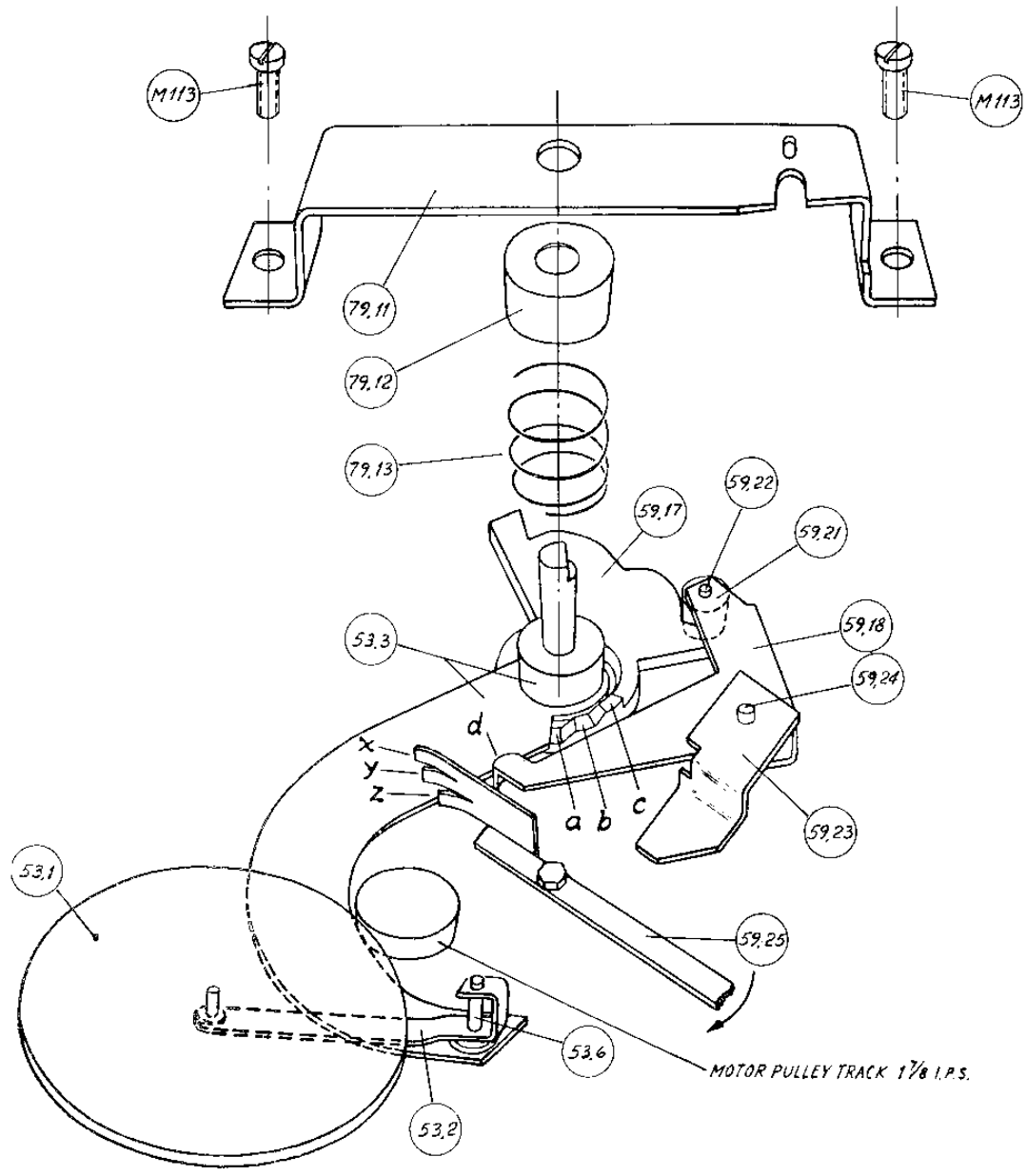

Fig. 15. Speed Change Mechanism

brake is introduced to prevent chattering of the speed transfer wheel (53.1) when the operating lever is pulled to Normal Forward Drive while the flywheel still is running. The speed transfer wheel may produce a chattering noise when the flywheel is running faster than the motor when being engaged. The brake spring (66.9) is mounted as shown in figs. 16 and 29.

**3.7 Mounting and Adjustment of Motor Pulley, Transfer Wheel, and Speed Change.**

- (Figs. 14, 15, 16, and 17).
1. Check that the turntables (65.1 and 65.2) are correctly adjusted according to part 3.3.
  2. Operating lever (54.1) is set in Neutral position, and the motor pulley (62.1) is fastened in such a position that the dividing rib of the motor pulley (62.1) is 0.5 mm (0.02") below an imaginary

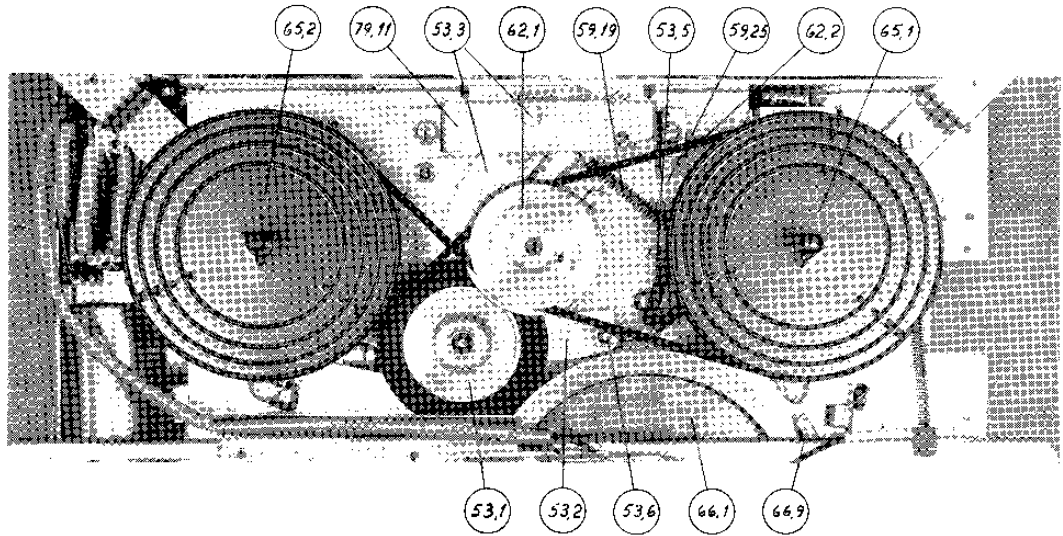

Fig. 16. Close-Up-View, Speed Change Mechanism

connection line between the bottoms of the V-shaped grooves in the pulley disc (61.1 or 61.2), (see fig. 14).

3. Speed change knob (53.4) is set to 1 7/8 ips position. The speed selector bracket (79.11) is adjusted (by loosening the screws (2 x M113)) until the transfer wheel arm (53.3) is parallel with the lower mounting plate (71.1) (approx. 1 mm (0.04") distance). Check that the transfer wheel arm (53.3) does not touch the lower mounting plate (71.1) in any position. Tool no. 6 (Fig. 32).

4. Check that the cam disc arm (59.18) moves the transfer wheel (53.1) safely away from the

next track on the motor pulley (62.1) before the slope on the cam disc (59.17) starts the lifting. In the working positions the spacing between the cam disc arm (59.18) and the transfer wheel mounting arm (53.3) at point d (fig. 15) is 0.5 mm (0.02"). If necessary the spacing is adjusted by bending the nose on the cam disc arm (59.18) (fig. 15). To make this adjustment the motor pulley (62.1) has to be removed.

5. Check that the transfer wheel (53.1) is lifted away from the motor pulley (62.1) in the three working positions of the speed change knob (53.4) when the operating lever (54.1) is in Neutral and

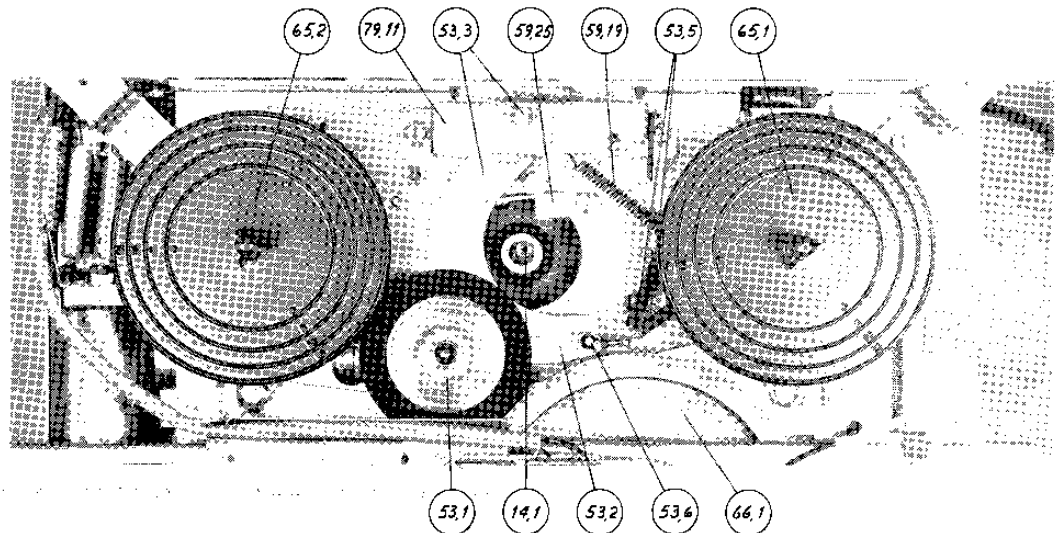

Fig. 17. Close-Up-View, Speed Change Mechanism, Motor Pulley and Belt Removed



Fast Winding positions. The lifting is accomplished by the transfer wheel lifting arm (59.25). If necessary the lifting is individually adjusted for the three speeds by bending the three split ends x, y, z (fig. 15) on the lifting arm (59.25). The lifting shall take place by a relative little movement towards Neutral positions of the operating lever (54.1). The lifting should have taken place before the motor current is broken by the micro-switch (33.5).

6. The spacing between the transfer wheel (53.1) and the pulley track for the next speed is adjusted by means of the turbax washers to 0.5 mm (0.02"). During the adjustment the motor pulley (62.1) has to be in its correct position, see 3.7 point 2. Check that the upper edge of the transfer wheel (53.1) is below the upper rim of the flywheel (66.1) in 7 1/2 ips position. If necessary, the flywheel (66.1) is lifted by an extra steel washer in the lower flywheel bearing.

The tape path is from the left to the right in playback and record positions. One adjustable (79.3) and three fixed tape guides (79.1, 79.2, and 79.4) provide the proper path of the tape. Correct contact between the pressure pad (59.4) and the erase head (15.3) together with uniform pressure of the pressure wheel (51.1) against the capstan (66.2) is of great importance (fig. 4). The adjustable tape guide (79.3) is inserted to secure against momentary unwanted movement of the tape and should normally not press against the

tape to avoid excessive noise and sometimes drop in the high frequency response. In correct position the heads (15.1, 15.2, and 15.3) and the tape should make good contact in the gap-zone and the gaps should stand in a right angle to the motion of the tape. The pressure pad should rest on the erase head with a pressure of 100 grams.

### 3.8 Start-Stop.

Fig. 18 shows how the movement of the start-stop magnet (33.1) is transferred by means of the two levers (51.5 and 51.8) to the pressure wheel (51.1). The magnet (33.1) is a push-magnet. When the magnet is energized, point A (fig. 18) at the bottom of the lever for start-stop (51.8) will be pushed away from the magnet. The lever (51.8) pushes the long lever for the pressure wheel (51.5). This lever (51.5) pushes the pressure wheel shaft (51.2) with the pressure wheel (51.1) away from the capstan (66.2). The friction between the pressure pad (59.4) and the tape will now stop the tape. When the current through the start-stop magnet is broken, the pressure wheel (51.1) will be pressed against the capstan (66.2), and the tape will again run.

### 3.9 Adjusting Start-Stop.

Set the mechanism in stop position (start-stop button released). The start-stop magnet (33.1) should be energized and the armature fully attracted. Bend the flat end, B, of the pressure

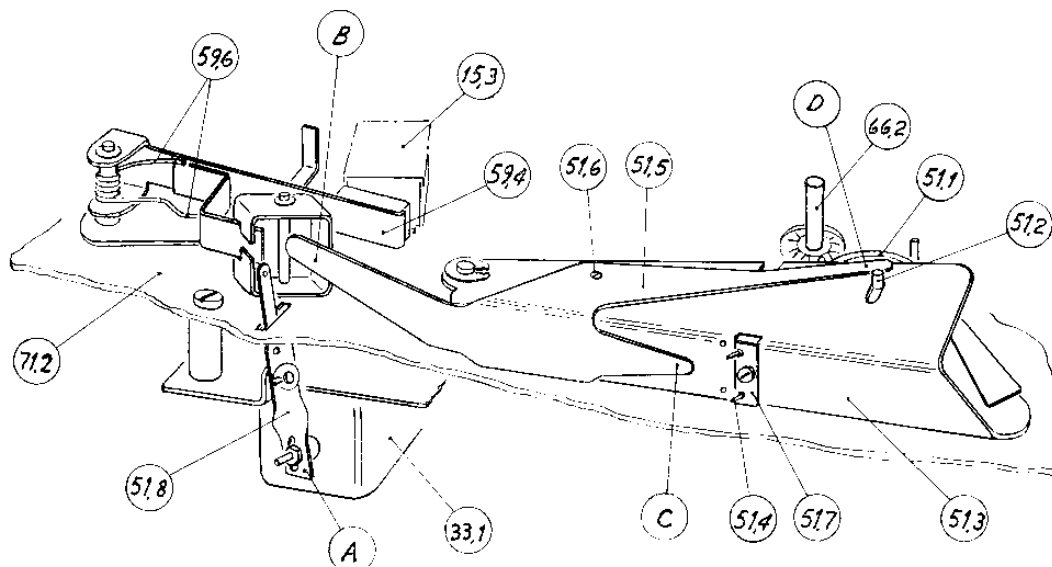
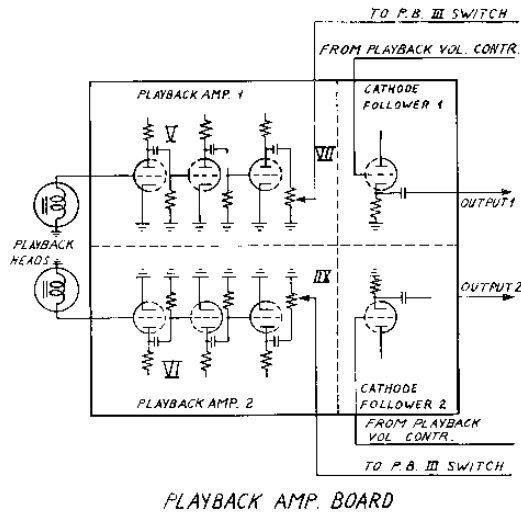
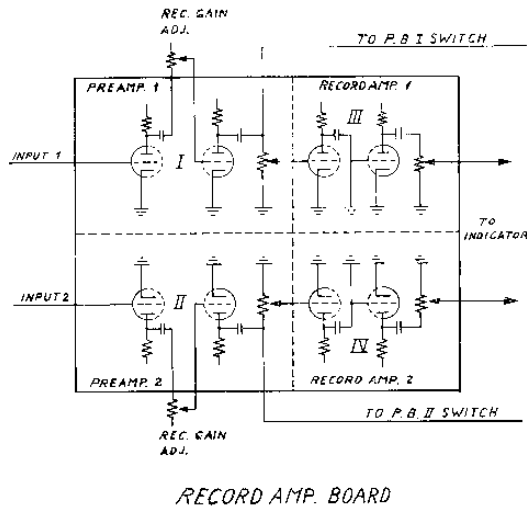

Fig. 18. Pressure Wheel Assembly and Start-Stop Magnet

wheel lever (51.5) so that a clearance is obtained between the pressure wheel (51.1) and the capstan (66.2) of approx. 0.5 to 1 mm (0.02" to 0.04"). In the start position no current flows through the start-stop magnet (33.1) and the tongue, C, on the pressure wheel lever (51.5) is bent so that a clearance between the ends, D, (fig. 18) and the pressure wheel shaft (51.2) of approx. 1 mm (0.04") is obtained. The pressure wheel lever (51.5) should move easily when it is not loaded, and should have a secure grip at the ends of the pressure wheel axis.



TUBE I-III IV V VI ECC83 (ALT. 12AX7-7025)

TUBE VII IX ECC82 (ALT. 12AU7)

Fig. 19. Record and Playback Amplifier Board, Simplified Diagram

#### 4. DESCRIPTION OF THE ELECTRONIC UNIT

The Tandberg Stereo, Model 6, has a completely new design of the electrical circuitry. Among the new features are; separate heads for erase, record, and playback, etched circuit boards for the amplifiers, the erase and bias oscillator, and for the record level indicator. The electrical circuitry is duplicated compared to a mono tape recorder in order to record and play back stereo.

The main parts are: 2 record preamplifiers for input program, 2 record amplifiers, 2 playback amplifiers, 2 cathode followers, 1 erase and bias oscillator, and 2 level indicators.

A simplified diagram is shown in Fig. 19.

By the push-button system the amplifiers can be interconnected in various combinations, creating a very flexible tape recorder.

#### 4.1 Operating Controls.

The electronic unit has the following operating controls:

Push-button center consisting of 2 record buttons, 2 playback buttons, and 1 start-stop button; speed selector switch; record gain control; playback volume control; and sound-on-sound switch.

The record buttons are mechanically coupled to the operating lever by the record lock-arm. The record buttons are locked in position Normal Forward Drive and automatically released when the operating lever is pushed to neutral.

The start-stop button operates the start-stop relay for the tape movement. It switches on the power to the bias and erase oscillator if one or both record buttons are depressed.

The playback buttons connect the output of the playback amplifiers to the cathode followers.

A complete diagram of the switches is shown in fig. 20. The push-buttons are numerated after their positions on the push-button center; i. e. I: record button channel 1 (upper). II: record button channel 2 (lower). III: start-stop button. IV: playback button channel 1 (upper). V: playback channel 2 (lower).

The speed selector switch performs the necessary mechanical switching and is mechanically coupled to the equalization switch which performs the electrical switching when the tape speed is changed.

The record and the playback vo-

Volume controls have both double knobs, one for the upper track and one for the lower. The sound-on-sound switch makes it possible to record sound-on-sound. The program

on one track is recorded on the other track mixed with what is played in. In normal record and playback modes the sound-on-sound switch has two positions; namely NOR-

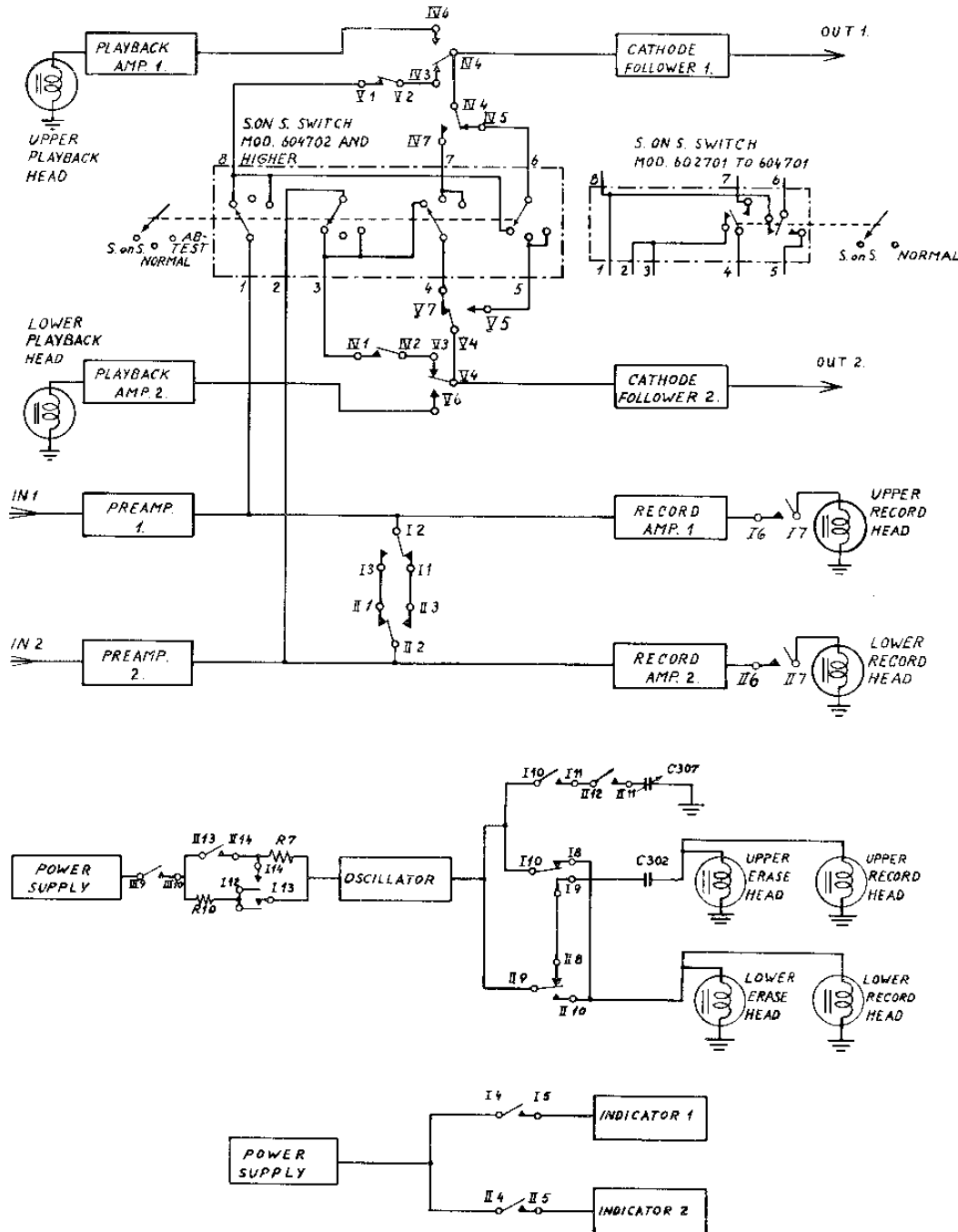

Fig. 20. Switching Diagram

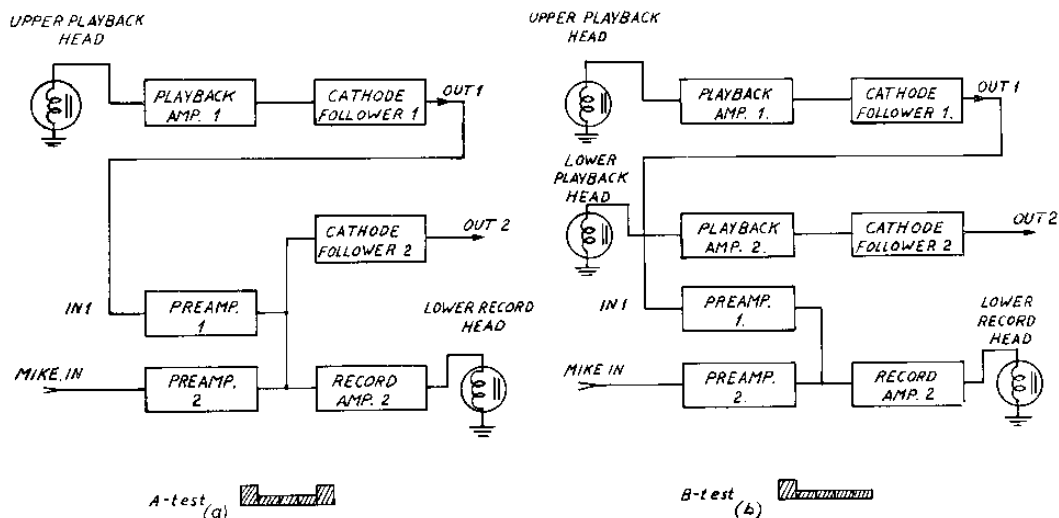

Fig. 21. Block Diagram

MAL and AB-test. No interconnection between the outputs of the preamps and the cathode followers inputs exists in position NORMAL. In the first recorders of Model 6 position NORMAL was not introduced, however, the NORMAL position on the first recorders is identical to the AB-test on the later recorders.

In A-test position the record preamplifier output is connected to the input of the cathode follower. The input program is then amplified through record preamp and cathode follower. During recording this is an A-test. With the button released, stop position, the recorder acts as an amplifier. In B-test position the output of the playback amplifier is connected to the cathode follower input. During recording this is a B-test.

If now the record input of the taperecorder is in any way connected to the cathode follower output, which may happen in some external amplifier set-ups, there may occur a feedback oscillation. Therefore the position «Normal» is introduced where the AB-test is taken away and this avoids the oscillation possibility.

The record level indicators are connected to the power supply when their respective record buttons are depressed. The oscillator is energized when the start-stop button (III) and one or both record buttons are depressed. When both record buttons are released the upper heads are connected to the lower heads through the capacitor, C302.

In all mono positions the outputs of the preamps are connected together i. e. inputs mixed. In stereo the recorder is divided into two identical electronic units, one for each channel.

In Fig. 33 is shown the preferred combinations for the push-buttons and the sound-on-sound switch position for the different operations. Many other combinations are possible, however, the other modes of operation are doubling or odd ones and outside the scope of this manual.

For sound-on-sound monitoring on the lower track the output of cathode follower 1 is connected to the high level input of channel 1 and the microphone connected to channel 2. The master recording and the mike input will be recorded on the lower track simultaneously. With buttons II, III, and IV depressed an A-test is performed, to make a B-test buttons II, III, IV, and V have to be depressed.

For sound-on-sound monitoring on upper track buttons, I, III, and V has to be depressed in A-test and in B-test buttons I, III, IV, and V.

Fig. 21 shows schematically how the different blocks are interconnected in sound-on-sound monitoring on the lower track.

Note that the playback head is located after the record head on the track, in B-test the program played in will after a delay (0.133 sec. for 7 1/2 ips) be played back.

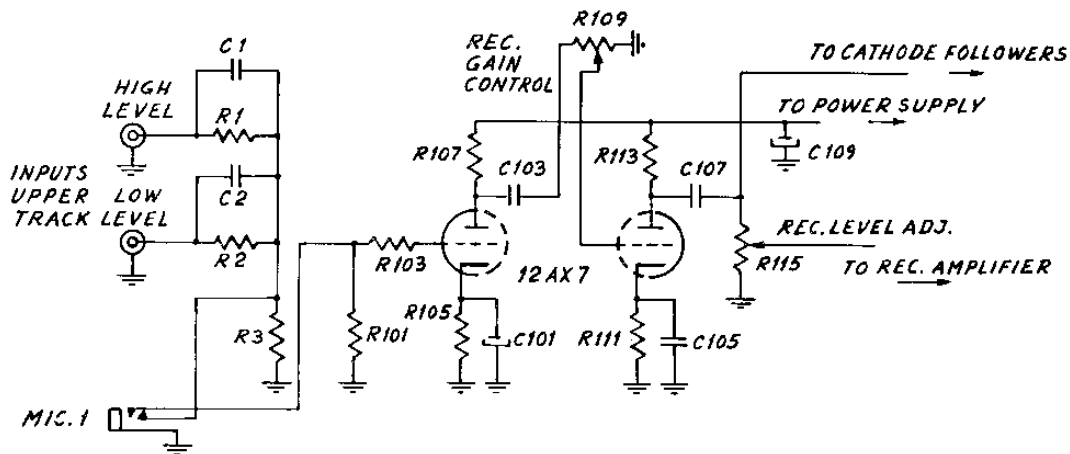

Fig. 22. Preamplifier for Recording.  
(Component Numbers for Upper Track)

## 4.2 THE AMPLIFIERS

In the following discussions only the amplifiers for the upper track are discussed, the lower track amplifiers are identical with the upper ones. All the tubes, except the ones for the oscillator and the indicators, have d-c filament heating to minimize hum in the recorder.

### 4.2.1 Preamplifier for Recording. (Fig. 22).

Both channels have three inputs: high level, low level, and microphone inputs. The high-level input signal goes through the voltage divider R1 and R3. The input signal to the grid is reduced by the ratio 1:27. The low-level input signal is divided by R2 and R3 in the ratio 1:2.7. The microphone is connected directly to the input of the tube. The series resistor in the grid circuit (R103) and the grid-to-cathode capacitance of the tube of

the first stage act as a filter for radio frequencies. The radio frequencies are rejected from the amplifiers.

Program mixing is possible through the high and low level inputs. Connection of microphone, however, disconnects the high and low inputs from the grid of the first stage.

The record preamp is a simple two-stage amplifier. A twin triode, 7025 (ECC83), is used for the two stages. The Record Gain Control, R109, is located between the two stages, i. e. the input to the second stage is controlled by R109. The input to the record amplifier is taken from the Record Level Adjustment resistor, R115 in the output of the preamplifier. The Record Level Adjustment resistor, R115, is adjusted for highest permissible distortion (3%) in the output of the cathode follower when the program is played

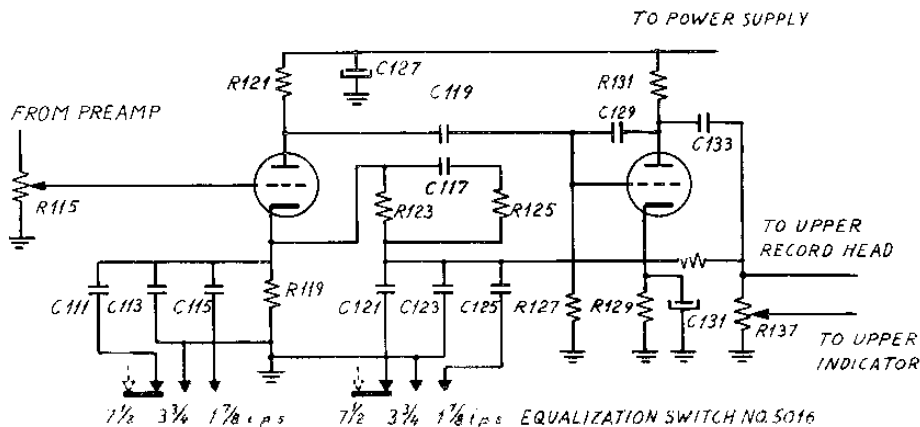

Fig. 23. Record Amplifier. (Component Numbers for Upper Track)

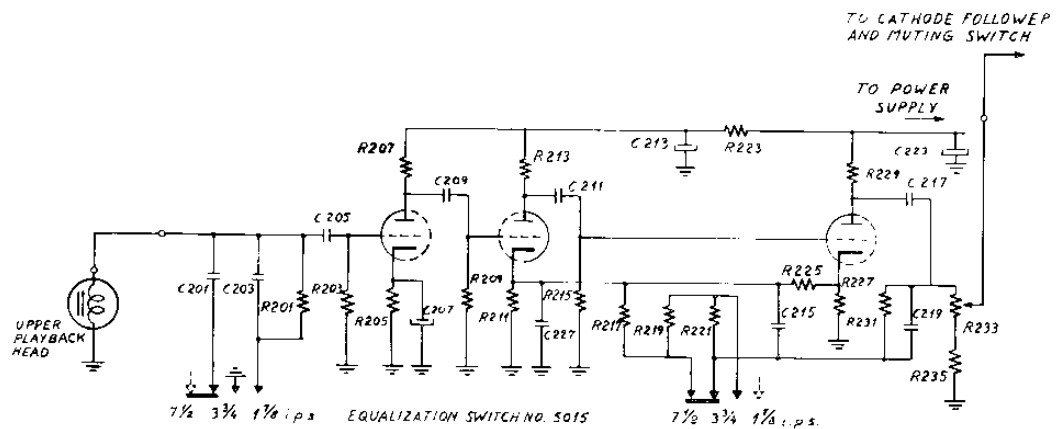

Fig. 24. Playback Amplifier. (Component Numbers for Upper Track).

back (B-test). The preamp is also connected to the cathode followers through the switching circuit.

#### 4.2.2 Record Amplifier. (Fig. 23).

The input is adjusted by the Rec. Level Adj. resistor, R115. The record amplifier is a two stage amplifier using a 7025 (ECC83), twin triode. The amplifier has negative feedback from the output of the second stage to the cathode of the first stage. High frequency compensation is performed by combinations of C111, C113, and C115 and C121, C123, and C125 depending on position of the tape speed switch (equalization switch). Low frequency compensation is obtained by R123, R125, and C117. See curves fig. 40.

Input to the record head is taken across the output resistor, R137. The center-tap of the output resistor, R137, is connected to the input of the record level indicator, R137 is adjusted for max. indication for max. permissible distortion.

#### 4.2.3 Playback Amplifier. (Fig. 24).

using the double triodes; 12AX7 (ECC83) (both sides) and 12AU7 (ECC82) (one side). The output of the playback head is connected to the grid of the first stage through the blocking capacitor, C205. An equalizing circuit (C201, C203, and R201) is connected in parallel with the playback head to correct for playback losses at high frequencies. Feedback (positive) from the cathode of the third stage to the cathode of the second stage boosts the bass according to NARTB standards. Speed compensation is obtained by varying the amount of feedback (negative) from the output

of the third stage to the cathode of the second stage by means of the resistor combination R217, R219, and R221. The output voltage is adjusted by the Playback Level Adjustment resistor, R233, for max. 1.5 volts out of the cathode follower.

When the operating lever is in any position except Normal Forward Drive, the muting switch is closed and the playback amplifier output is shorted to prevent noise when the recorder is used as a preamplifier. See curves fig. 41.

#### 4.2.4 Cathode Follower. (Fig. 25).

The cathode follower uses one half of the twin triode, 12AU7 (ECC83). The input is adjusted by the playback volume control, R18. The capacitor,

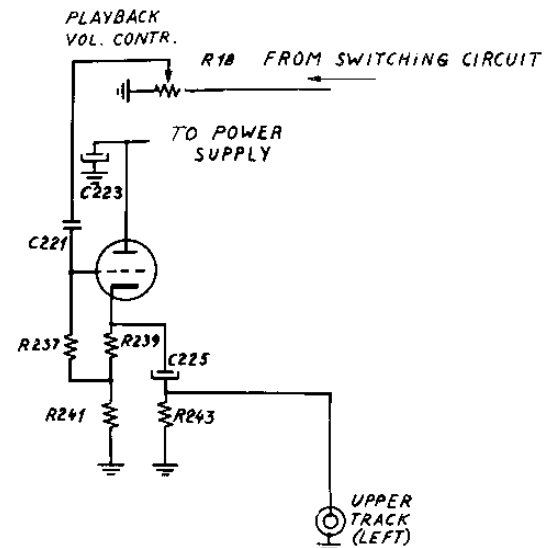

Fig. 25. Cathode Follower. (Component Numbers for Upper Track)

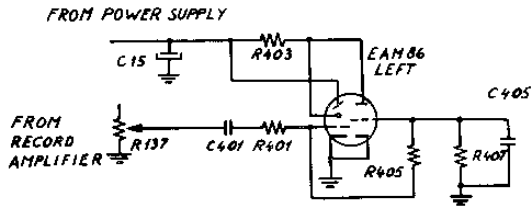

Fig. 26. Record Level Indicator. (Component Numbers for Upper Track)

C225, blocks d-c from the output terminals. Max. output for 3% distortion from record to playback is 1.5 volts.

The load resistance must be at least 2 Kohms to keep distortion below the permissible level.

#### 4.2.5 Magic Eyes. (Fig. 26).

The magic eye receives its signal voltage from the voltage divider, R137. The indicator tube, EAM86, is actually three tubes in one, a rectifier, a triode, and an indicator. The input signal is rectified, amplified, and controls the indicator. The rectified wave is «smoothed out» by the damping circuit, R407 and C405, to damp the backward movement of the indicator. The magic eye will close completely at a signal level corresponding to 3% distortion on the tape. The eye

maintains its sensitivity over the entire audio range, from 30 to 20 000 cps. The recording current sensitivity is adjusted by the indicator adjust- ment resistor, R137.

#### 4.2.6 Erase and Bias Circuitry. (Fig. 27).

The oscillator is of the push-pull type using the twin triode, 12AU7 (ECC82). A push-pull oscillator has the advantage of producing negligible even harmonics.

The d—c supply is fed into the center-tap of the inductor, L1. When either one or both record channels are connected, the output across L1 must be kept constant. This is accomplished by supplying the oscillator with the corresponding plate voltages. See II 13-14, I 12-13-14, R7 and R10. The Balance Control, R307, is adjusted for minimum distortion in the output (even harmonics). The frequency is set to 78 Kcps by adjusting the core in the oscillator coil, L1.

The oscillator is connected directly to the lower erase head and through the capacitor, C302, to the upper erase head. The capacitance in series with the inductance and resistance of the erase and record heads will cause damped oscillations for switching transients and only negligible resi-

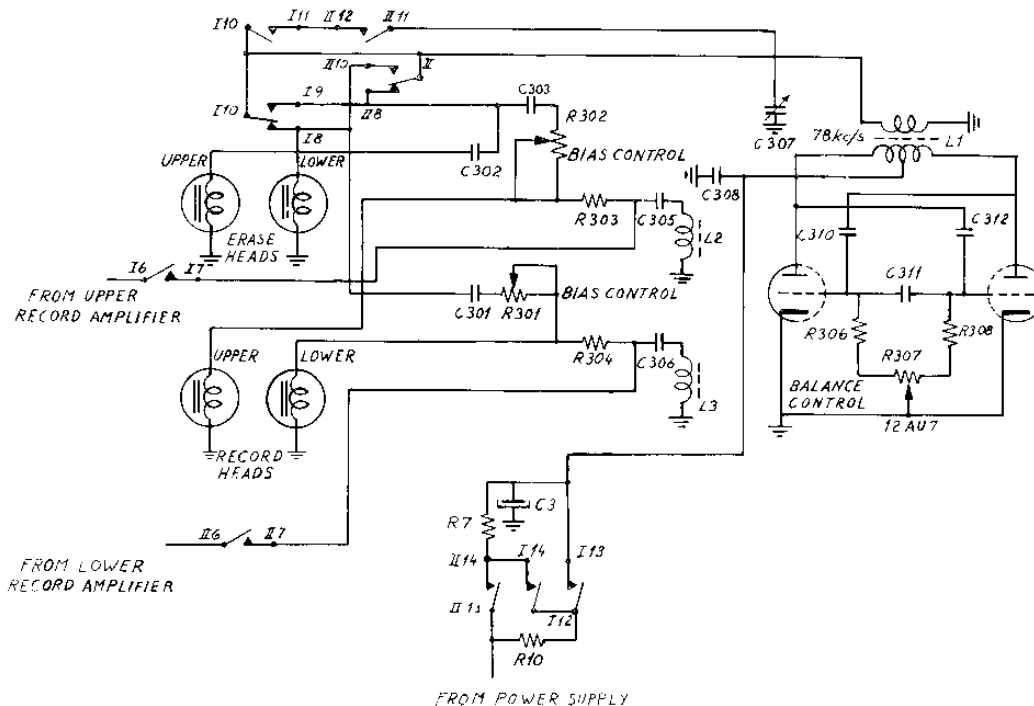

Fig. 27. Erase and Bias Circuitry

dual magnetism will therefore remain in the erase and record heads.

The oscillator also supplies bias current to the record heads. The right amount of bias (50 volts, 78 Kcps) is adjusted with the bias controls, R302 and R301. To prevent bias current (78 Kcps) flowing into the output circuit of the record amplifiers, filter circuits are connected to the points 34 and 37. This arrangement prevents the oscillator from modulating the program. The components of filter circuits are L2 - C305 and L3 - C306. The rejectors are adjusted by the rejector inductors, L2 and L3, for min. voltage at points 51 and 52 on the indicator board (less than 150 mvols, 78 Kcps).

The capacitor, C307, is adjusted for 78 Kcps oscillator frequency with the recorder in stereo position to compensate for the loading by the erase and record heads in stereo position.

When recording in stereo the magnetic field pro-

duced by the two erase head halves is 180° out of phase to prevent unwanted erasure of the track in between the two tracks being recorded.

## 5. INSTRUCTIONS FOR MECHANICAL CHECK-UP

After repair, a mechanical check-up should be performed. While repairing, the top cover (74.1) has probably been removed and some of the checking ought to be done before replacing the top cover (74.1). Make sure that the prescribed tolerances are maintained and that the drive mechanism works satisfactorily. In case of dubious operation look up the points in the detailed description and ascertain satisfactory operation.

### 5.1. Fast Winding.

A reel of tape (1200 feet) should be wound fast forward or reverse in 1 ¼ minute. Make sure that start of fast winding can take place even when

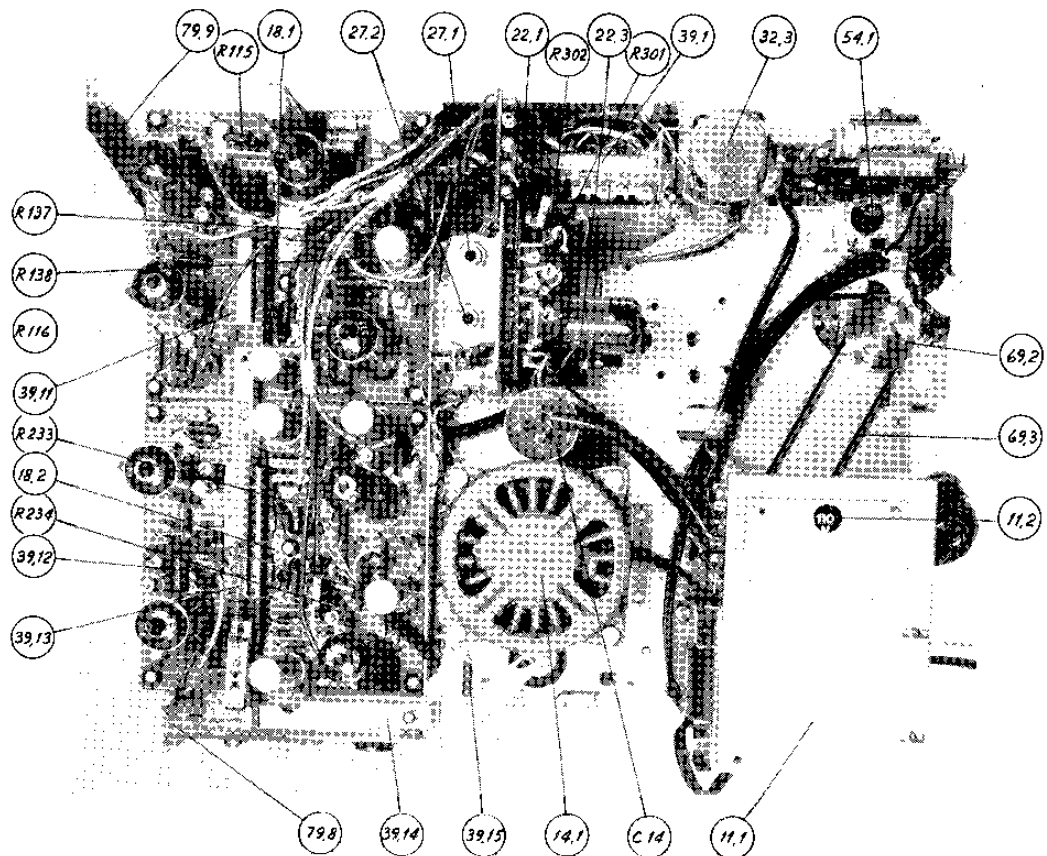

Fig. 28. Under View



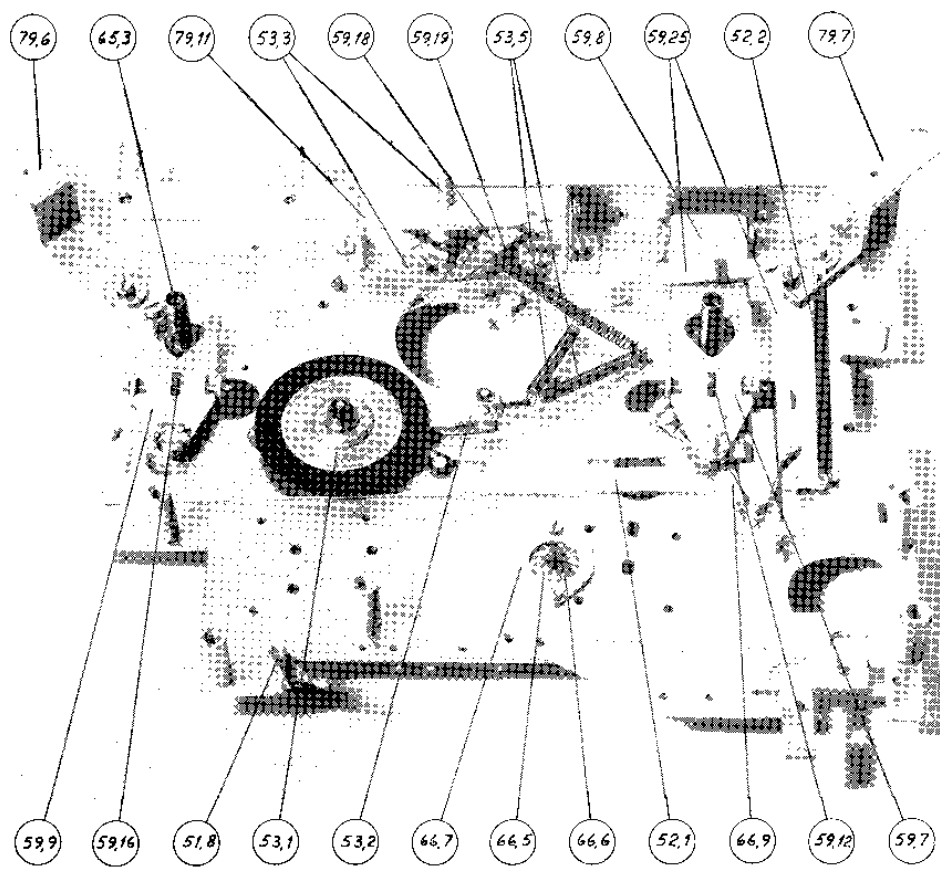

Fig. 29. Lower Mounting Plate, Upper Mounting Plate Removed.

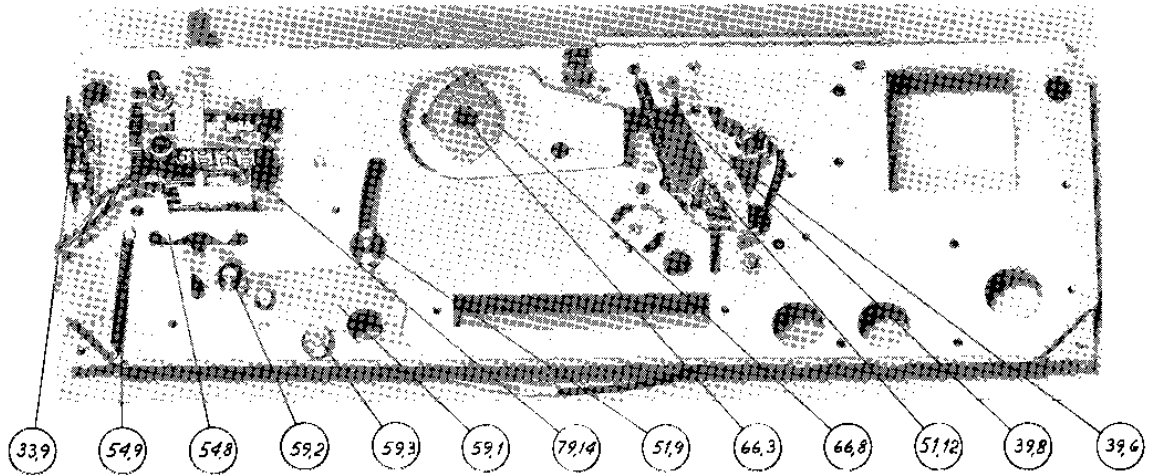

Fig. 30. Upper Mounting Plate. Under View

the supply reel is almost empty. Also make sure that levers and pulley discs are correctly adjusted as shown in the photographs (figs. 9 to 13). Check that the tape reels do not rub against the top cover. Ascertain sufficient clearance.

The transfer wheel (53.1) should be lifted away from the motor pulley (62.1) at all speeds when the operating lever (54.1) is set to neutral or fast winding positions.

## 5.2. Normal Forward Drive.

The speed transfer wheel (64.1) must run freely without any throw or vibration. In the position for the two lower speeds there must be sufficient clearance between speed transfer wheel (53.1) and motor pulley (62.1).

The friction in speed transfer system should be sufficient at all speeds to stop the motor by holding the flywheel (66.1). Both pulley discs (61.1 and 61.2) should be checked and the levers (59.7, 59.8, and 59.9) should be as described in the detailed description. The take-up torque of the right hand reel should preferably be measured; 20—25 grams (0.7—0.9 ounces) at a radius of 8 cm (3") or 160—200 gram-centimeters (2.2—2.8 ounce-inches). The tape should not move with the operating lever (54.1) in Normal Forward Drive and Start Stop button released when the right hand reel is almost empty. If the tape moves; the take-up torque is too high or the pressure pad too weak.

Start by means of the on-off switch (full load instantaneously) should be possible with a line voltage 15% below the voltage selector setting.

The path of the tape should carefully be checked out. Make sure that the tape does not rub against

the flanges of the adjustable tape guide. The pressure pad arm (59.6) with the felt pad should exert a force of 100 grams (4 ounces) against the erase head (15.3) and must not give rise to «climbing». The pressure wheel assembly must be adjusted so that the stud in front of the pressure wheel is flush with the edge of the rear trim cover (73.2).

Make sure that the stud on the pressure wheel assembly (51.3), the pressure wheel (51.1), and the pressure pad (59.6) do not prevent the tape from dropping into its path when inserted into the slit between the trim covers (73.1 and 73.2). The pressure wheel shaft (51.2) must be parallel to the capstan (66.2). If not, carefully adjust the spring equalization latch (51.7) on the pressure wheel assembly (51.3). Do not correct the path of the tape by adjusting the spring equalization latch (51.7). Incorrect path of the tape has usually other causes than incorrect alignment of the pressure wheel (51.1) and will not be corrected by such an adjustment. The pressure of the pressure wheel spring (51.4) holding the pressure wheel (63.1) should be about 0.7 kilograms, (1.5 lbs). The pressure influences the tape speed and should not be changed without a tape speed test. If necessary, a complete adjustment of the tape path and head alignment is carried out according to sec. 6.2.

When replacing the top cover (74.1) ascertain that the screws and washers are put back in their proper positions. After the top cover (74.1) has been put back in place, recheck the mechanical functions for proper operation. The spacing between tape reels and top over (74.1) must be checked to be sufficient for all positions of the operating lever (54.1).

## 6. INSTRUCTIONS FOR ELECTRICAL CHECK-UP

- 6.1. ADJUSTMENT OF OSCILLATOR AND SUPPRESSOR COIL
- 6.1.1 Depress buttons I and III, and set operating lever to normal forward drive. Adjust the core in the oscillator coil to a frequency of 78—80 kcps. Connect a VTVM to point 51 on indicator board. Adjust the suppressor coil, L2, to min. voltage on VTVM (less than 150 mV).
- 6.1.2 I, II, and III depressed and normal forward drive. Adjust variable capacitor, C307, on the oscillator board to min. voltage (less than 150 mV) at point 51.
- 6.1.3 Move VTVM to point 52 on indicator board and adjust L3 to min. voltage (less than 150 mV). I, II, and III depressed and normal forward drive.
- 6.2. ADJUSTMENT OF THE HEADS
- 6.2.1 **Demagnetizing.**  
Demagnetize the heads and adjacent parts.
- 6.2.2 **Preliminary Adjustment.**
- 6.2.2.1 **The Playback Head.**  
6.2.2.1.1 The height of the head is adjusted by the height adjustment screws. Fig. 4. The upper edge of the tape should run even with the upper air gap of the head. (For exact height position, see 6.2.3). Be sure that the mounting plate for the heads and the upper mounting plate are parallel.
- 6.2.2.1.2 Adjust the playback head with the azimuth alignment screw fig. 4 for max. reading on both instruments by playing back a standard azimuth alignment tape.
- 6.2.2.1.3 Lift the pressure pad away from the tape. If the meter readings decrease more than 3 dB, turn the playback head by turning the head mounting plate. The direction is determined by increasing the contact angle to the right or the left side of the head by means of a nonmagnetic pin (f. ex. if the meter reading increases by increasing the contact angle on the right side of the gap, turn the head clockwise).
- 6.2.2.1.4 If adjustment 6.2.2.1.3 made, recheck the azimuth alignment of the playback head.
- 6.2.2.2 **The Record Head.**
- 6.2.2.2.1 Approx. 0.003" of the face of the record head should be visible above the tape. (For exact height position, see 6.2.3).
- 6.2.2.2.2 Insert blank tape. The signal generator, 10 000 cps, is connected to both amplifiers. Depress all buttons. Adjust the recording volume control to max. recording level.
- 6.2.2.2.3 After proper adjustment of playback head the record head can be adjusted. Record 10 000 cps at 7 ½ inch speed and adjust the record head to max. output from playback head in B-test. Check the contact angle according to 6.2.2.1.3.
- 6.2.2.2.4 If adjustment 6.2.2.2.3 made, recheck the azimuth alignment of the record head.

- The Erase Head.
- 6.2.2.3.1 0.01" of the face of the erase head should be visible above the tape. (For exact height adjustment, see 6.2.3).  
The head must be parallel with the mounting plate for the heads.  
The press of the pressure pad should be 100 grams.
- 6.2.2.3.2 Set operating lever to normal forward drive and check that the tape runs equidistant from the flanges of the adjustable tape guide.
- 6.2.3 **Track Control and Fine Adjustment.**
- 6.2.3.1 Record Head.
- 6.2.3.1.1 Insert blank tape. Connect the signal generator (1000 cps) to both amplifiers. Depress buttons I, II, and III and record at max. recording level a suitable length of tape (f. ex. 1 1/2') on tracks I and III. Turn the tape and record on tracks II and IV. The recorded tape is cut off the reel and put in a mixture of iron powder and alcohol (to make the track visible (Magna-See)).
- 6.2.3.1.2 If the picture shows that the position of the record head is incorrect, the height of the head must be corrected. Corresponding the azimuth position must be adjusted, 6.2.2.1.2 and 6.2.2.1.3.
- 6.2.3.1.3 Repeat 6.2.3.1.1 and 6.2.3.1.2 until satisfactory results are obtained.
- 6.2.3.2 Erase Head.
- 6.2.3.2.1 Insert a full-track recorded tape. Record a suitable length of tape on lower track. Put the rerecorded tape in the iron mixture.
- 6.2.3.2.2 Check that the rerecorded track lies within the erased track. Adjust the erase head if necessary and recheck and 6.2.3.2.1 until satisfactory results are obtained.
- 6.2.3.3 Playback Head.
- 6.2.3.3.1 Record a 1000 cps signal at max. level on track I and a 500 cps signal on track III. Turn the tape and play back track II at max. playback volume (III and IV depressed). No signal should appear in the output.
- 6.2.3.3.2 If 1000 cps is heard, the playback head has to be raised.
- 6.2.3.3.3 If 500 cps is heard, the playback head has to be lowered.
- 6.2.3.3.4 If a correction necessary, check 6.2.2.1.

### 6.3. ADJUSTMENT OF BIAS

Connect the signal generator (3000 cps) to both amplifiers (high level input). Connect output meters to output jacks and insert tape. Depress all buttons and set operating lever to normal drive. Adjust the pot.meters R301 and R302 on the oscillator board for max. reading on both meters.

### 6.4. RECORDING CURRENT, MEASUREMENTS OF DISTORTION

- 6.4.1 Set the playback volume controls to max. Connect a signal generator, 400 cps, to the input. Depress buttons I and II, and set the operating lever to normal drive. With a VTVM measure the voltage at the output terminals. Adjust the record volume control for 1.5 volts out.

- 6.4.2 Connect a distortion meter to the output jack. Record and play black (depress button III, IV and V) 400 cps on upper and lower track respectively with the corresponding amplifiers. Adjust the recording current by R115 and R116 (record-amp. board) respectively for 3 % distortion.
- 6.4.3 Adjust R137 and R138 (record-amp. board) so that the recording lever indicator light beams touch each other.
- 6.4.4 While recording and playing back adjust R233 and R234 in the playback amplifier for 1.5 volts output. Be sure that the playback volume control is set to max.
- 6.4.5 Release buttons IV and V and check that the output still is 1.5 volts.
- 6.5. MIXING OF PROGRAMS
- 6.5.1 Depress either button I or II. The record amplifiers are now connected together. If signals are put in to both pre-amplifiers simultaneously, the signals will be mixed.
- 6.6. STEREO RECORDING CHECK
- To check stereo, record a signal on one channel and record from a microphone on the other. Play back the program.
- 6.7. AMPLIFIER OPERATION
- All buttons released. Signal connected to either channel 1 or 2. The signal should appear in the corresponding output.
- 6.8. PLAYBACK AMPLIFIER TEST
- 6.8.1 Feed channel 1 from signal generator and depress buttons I, III and IV. Turn one of the playback volum controls to zero, the other on. The signal should appear in the output of the cathode follower turned on. Reverse the two playback volum controls and check that the signal appears in the other output.  
Feed channel 2 and depress buttons II, III and V. Follow the procedure described for channel 1.
- 6.8.2 Insert NARTB standard frequency tape. Depress buttons III, IV, and V and set the operating lever to normal drive. At 250 cps set the output meters to zero dB and play back the remaining tape. Tolerances  $\pm 2.5$  dB for all frequencies. However, the difference between the curves must not be more than 3 dB for any frequency.
- 6.9. RECORD- AND PLAYBACK CURVES
- 6.9.1 Signal input (1000 cps) to both amplifiers. Speed  $7\frac{1}{2}$  ips. Record volume controls adjusted so that the record level light beams touch each other. To avoid overload of the tape at the high frequency end decrease the input 26 dB. Depress all buttons and set the operating lever to normal drive. Record and play back (B-test) the whole frequency range and check the frequency response curves.
- 6.9.2 Repeat 6.9.1 for  $3\frac{3}{4}$  and  $1\frac{7}{8}$  ips.

#### 6.10. SPEED CHECK

Make sure that the flywheel and the transfer wheel move freely. Use a tape with a marked section of 450 inches (1144 cm) (start and end markers). Measure the time for the tape-section to pass by the recording head. Correct time: 1 minute for  $7\frac{1}{2}$ "/s, 2 min. for  $3\frac{3}{4}$ ", and 4 min. for  $1\frac{7}{8}$ ".

Speed tolerance:  $\pm 1\%$  for all speeds.

#### 6.11. MICROPHONE AND ERASE CHECK

Record with the microphone on both tracks with max. recording level. With all buttons depressed the program can be played back simultaneously. Rewind the tape. Set the record volume control to zero. Erase the program by depressing buttons I, II, and III and the operating lever set to normal drive. Rewind and play back with the playback volume controls on max., (III, IV, and V depressed). Check that the program is erased completely or only faintly heard through noise.

#### 6.12. SOUND-ON-SOUND

Sound on sound switch in position «S-on-S.». Insert a tape recorded on the upper track. Depress buttons II, III, IV, and V. Record on the lower track by a microphone and simultaneously play back both channels. The program being recorded should be heard in the output of channel 1 and the program on tape should be heard in the output of channel 2.

#### 6.13. FUSES

The fuse board is located as shown in fig. 31. To replace fuses the recorder has to be lifted out of the cabinet.

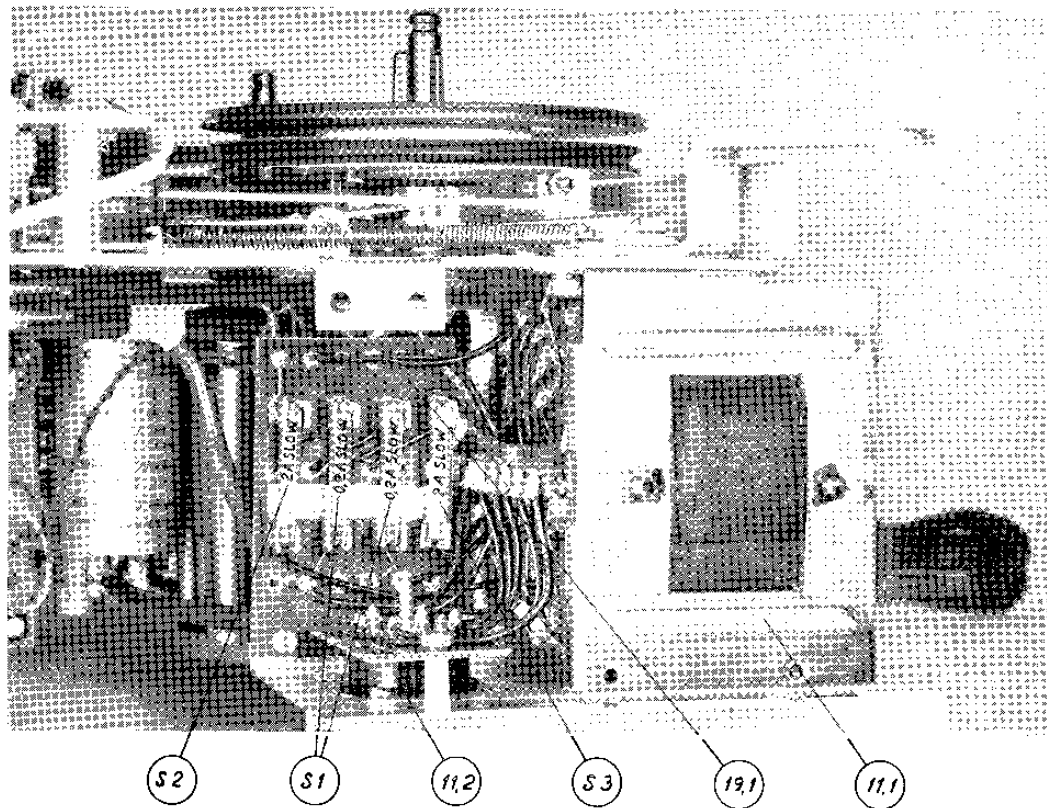

Fig. 31. Fuse Board

7. PARTS LIST  
7.1. Mechanical Parts.

Order No.	Ref. No.	Description	Shown in Fig.:
110.14	11.1	Power transformer	3, 5, 28, 31
145.68	11.2	Voltage coupler	28, 31
115.4	14.1	Motor, Papst	5, 14, 17, 28
138.21	14.2	Mounting plate, motor	
145.67	14.3	Rubber mounting (G8)	
125.5	15.1	Record head	4
125.6	15.2	Playback head	4
125.54	15.3	Erase head	4, 18
138.22	17.1	Terminal plate with phono jacks, upper track	3, 5
138.23	17.2	Terminal plate with phono jacks, lower track	3, 5
131.60	18.1	Record amplifier board with components	28
131.61	18.2	Playback amplifier board with components	28
112.12	19.1	Fuse board	31
138.24	19.2	Mounting strip, record head	4
138.25	19.3	Mounting strip, playback head	4
138.26	19.4	Mounting strip, erase head	4
137.9	22.1	Oscillator board with components	28
138.27	22.2	Subchassis for oscillator board	
137.8	22.3	Oscillator coil, L1	28
137.10	27.1	Coil, rejector circuit, L2	28
137.11	27.2	Coil, rejector circuit, L3	28
138.38	31.1	Indicator board with components	
133.53	32.1	Double potentiometer, record gain control	
107.61	32.2	Double knob, record gain control	1
133.54	32.3	Double potentiometer, playback volume control	
107.62	32.4	Double knob, playback volume control	1
111.23	32.5	Rectifier, high voltage (B250, C75), (Flat type)	
(111.22)	32.6	Rectifier, filaments (B30, C1000), (Flat type)	
140.8	33.1	Start-stop magnet	18
140.9	33.2	Coil, start-stop magnet	
140.10	33.3	Armature, stop magnet	6, 7
140.11	33.4	Coil, stop magnet	
(134.41)	33.5	Micro-switch	6
(127.2)	33.6	Plate-spring, micro-switch	6
145.69	33.7	Actuator lever, micro-switch	6
145.70	33.8	Shaft, actuator lever	6
(134.1)	33.9	Line switch (ON-OFF)	1, 30
(107.51)	33.11	Slip-on knob, line switch	
142.53	33.12	3 prong socket, remote control	3, 5

Order No.	Ref. No.	Description	Shown in Fig.:
145.71	39.1	Push-button center	1, 3, 28
145.72	39.2	Arm, record-lock	
127.24	39.3	Spring, record-lock arm	
135.37	39.4	Sound-on-sound switch	
145.73	39.5	Lever, sound-on-sound switch	1
134.88	39.6	Muting switch	30
145.74	39.7	Arm, muting switch	
127.25	39.8	Spring, muting switch	30
135.9	39.11	Equalization switch, record amplifier	28
135.10	39.12	Equalization switch, playback amplifier	28
127.27	39.13	Spring, equalization switch	28
145.75	39.14	Arm, equalization switch	5, 28
127.28	39.15	Spring, equalization switch arm	5, 28
131.50	44.1	Pilot lamp, 6.3 volts	3
142.56	44.2	Socket, pilot lamp	
142.42	45.1	Microphone jack	1, 3
100.15	48.1	Wooden case	
145.76	48.2	Buffer, polyethylen	
(120.1)	51.1	Pressure wheel	4, 18
145.77	51.2	Shaft, pressure wheel (see 51.1)	18
(120.51)	51.3	Pressure wheel bracket (delivered with 51.1, 51.2, 51.4, 51.5, and 51.7)	3, 4, 18
127.29	51.4	Spring, pressure wheel	18
145.78	51.5	Lever, pressure wheel	4, 18
145.79	51.6	Shaft, pressure wheel lever	4, 18
(145.39)	51.7	Spring equalization latch	18
145.80	51.8	Start-stop lever	18, 29
(145.22)	51.9	Roller for pressure wheel bracket	30
(145.23)	51.11	Axis for 51.9	
127.26	51.12	Spring for pressure wheel bracket	30
(145.26)	52.1	Trip bar	9, 10, 11, 12, 13, 29
(127.10)	52.2	Extension spring, trip bar	29
(121.2)	53.1	Speed transfer wheel	14, 15, 16, 17, 29
145.81	53.2	Transfer wheel holder	14, 15, 16, 17, 29
145.82	53.3	Mounting arm, transfer wheel, with speed selector shaft	14, 15, 16, 17, 29
(107.31)	53.4	Knob, speed selector	1
(127.7)	53.5	Spring, transfer wheel holder	16, 17, 29
(145.7)	53.6	Shaft, transfer wheel holder	14, 15, 16, 17
135.64	54.1	Operating lever, mounted	28
(145.17)	54.2	Operating lever, only	3, 6, 7
(107.41)	54.3	Knob, operating lever	1
(127.15)	54.4	Spring, operating lever knob	
(127.11)	54.5	Guide spring, operating lever	
127.30	54.6	Spring, operating lever	6, 7
145.82	54.7	Rubber mounting (G8)	6
145.83	54.8	Operating lever arrester	30
127.31	54.9	Spring for 54.8	30



Order No.	Ref. No.	Description	Shown in Fig.:
(145.19)	59.1	Eccentric segment	30
(145.20)	59.2	Shaft, eccentric segment (stud)	30
(145.21)	59.3	Movement limiter, eccentric segment	30
145.84	59.4	Pressure pad arm	4, 18
145.85	59.5	Pressure pad, felt	4
127.32	59.6	Spring for 59.4	4, 18
145.86	59.7	Upper clutch lever, take-up pulley disc, right	8, 9, 10, 11, 29
(145.15)	59.8	Lower clutch lever, take-up pulley disc, right	8, 9, 10, 11, 29
145.87	59.9	Clutch lever, supply pulley disc, left	12, 13, 29
145.88	59.11	Shaft for 59.7	9, 10, 11
127.33	59.12	Spring for 59.7	9, 10, 11, 29
(145.16)	59.13	Shaft for 59.8	
127.34	59.14	Spring for 59.8	
145.89	59.15	Shaft for 59.9	12, 13
127.35	59.16	Spring for 59.9	12, 13, 29
(145.10)	59.17	Cam disc	5, 15
(145.11)	59.18	Cam disc arm	5, 15, 29
(127.4)	59.19	Extension spring, cam disc arm	16, 17, 29
(145.13)	59.21	Roller for cam disc arm	5, 15
(145.14)	59.22	Axis for cam disc arm roller	5, 15
145.90	59.23	Bracket for cam disc arm shaft	15
(145.12)	59.24	Shaft for 59.18	15
(145.8)	59.25	Transfer wheel lifting arm with linkage arm	15, 16, 17, 29
(119.51)	61.1	Pulley disc (delivered with roller bearing and 61.5)	8, 9, 10, 11, 14
119.2	61.2	Supply pulley disc (delivered with roller bearing and 61.5)	12, 13, 14
(127.8)	61.3	Helical compression spring, take-up pulley disc	8, 9, 10, 11
(127.9)	61.4	Helical compression spring, supply pulley disc	12, 13
145.91	61.5	Cartridge, pulley disc (see 61.1 or 61.2)	8, 9, 10, 11, 12, 13
(116.53)	62.1	Motor pulley	3, 14, 16
(117.2)	62.2	Rubber belt, motor pulley	16
(119.1)	65.1	Turntable with felt, right (take-up)	3, 8, 9, 10, 11, 14, 16, 17
(119.2)	65.2	Turntable with felt, left (supply)	3, 12, 13, 14, 16, 17
(145.33)	65.3	Housing for turntable bearing	8, 14, 29
(118.2)	66.1	Flywheel (delivered with 66.2 and 66.3)	3, 14, 16, 17
145.92	66.2	Capstan (see 66.1)	3, 4, 18
(145.31)	66.3	Bushing, flywheel bearing	4, 30
(127.16)	66.4	Spring for upper flywheel bearing	4
(127.12)	66.5	Spring for lower flywheel bearing	29
(145.1)	66.6	Felt ring	4, 29
(145.29)	66.7	Latch for flywheel bearing	4, 29
(145.30)	66.8	Latch for flywheel bearing	30
127.36	66.9	Brake spring, flywheel	16, 29

Order No.	Ref. No.	Description	Shown in Fig.:
145.93	69.1	Pulley disc for revolution counter (turntable) . . .	
145.94	69.2	Pulley disc for revolution counter (counter) . . . .	28
117.3	69.3	Rubber belt, revolution counter . . . . .	28
138.29	71.1	Lower mounting plate . . . . .	3, 8, 14
138.30	71.2	Upper mounting plate . . . . .	3, 18
(145.34)	72.1	Flange for turntable housing (see 61.1) . . . . .	8
102.3	73.1	Front trim cover . . . . .	1
102.33	73.2	Rear trim cover . . . . .	1
141.6	73.3	Screw for trim cover . . . . .	1
138.31	73.4	Bracket for 73.1 . . . . .	
138.32	73.5	Bracket for 73.1 . . . . .	
138.33	73.6	Bracket for 73.2 . . . . .	
101.32	74.1	Top metal plate cover . . . . .	1
141.7	74.2	Screw for top cover (4 x 24 mm) . . . . .	1
(139.9)	74.3	Rubber mounting for 74.2 . . . . .	1
141.8	74.4	Washer for mounting screws . . . . .	
141.9	74.5	Screw for top cover (3 x 6 mm) . . . . .	1
145.95	79.1	Tape guide . . . . .	4
145.96	79.2	Tape guide . . . . .	4
145.97	79.3	Tape guide, adjustable . . . . .	4
145.98	79.4	Tape guide . . . . .	3, 4
145.99	79.5	End-stop contact . . . . .	3
(138.12)	79.6	Mounting bracket, left rear . . . . .	5, 29
(138.13)	79.7	Mounting bracket, right rear . . . . .	5, 29
146.0	79.8	Chassis leg, left rear . . . . .	5, 28
146.1	79.9	Chassis leg, left front . . . . .	28
146.2	79.11	Speed selector bracket . . . . .	15, 16, 17, 29
(145.41)	79.12	Cup for speed selector spring . . . . .	15
(127.13)	79.13	Spring, speed selector . . . . .	15
146.3	79.14	Revolution counter . . . . .	1, 30
146.4	79.15	Tube shield . . . . .	
127.37	79.16	Spring, tube shield . . . . .	
146.5	79.17	Hook, tube shield spring . . . . .	
(145.49)	79.18	Cover plate I . . . . .	3
(154.50)	79.19	Cover plate II . . . . .	3
127.38	79.21	Spring, cover plates . . . . .	
146.9	79.22	Stereo emblem . . . . .	
146.10	79.23	Tandberg emblem . . . . .	
146.6	79.24	Window, revolution counter . . . . .	
146.7	79.25	Window, indicator . . . . .	1
127.39	79.26	Spring for fuse holder . . . . .	
146.8	79.27	Rubber mounting tube (for printed circuit boards)	
	79.28	Lock spring, turntables . . . . .	8

7.2 Electrical Parts.  
7.2.1 Resistors.

R1	1 Mohm	1/2 watt	10%	Ins. Carbon-Film SBT	Vitrohm
R2	68 000 ohm	1/2	10	Ins. Carbon-Film SBT	Vitrohm
R3	39 000 "	1/2	10	"	"
R4	39 000 "	1/2	10	"	"
R5	68 000 "	1/2	10	"	"
R6	1 Mohm	1/2	10	"	"
R7	3 900 ohm	1/2	10	Cracked-Carbon	Rosenthal SCD or NSF
R8	510 "	1/2	10	"	"
R9	1 200 "	1/2	10	"	"
R10	3 900 "	1/2	10	"	"
R11	5 000 "	3	10	Wire Wound CZ 00,025	Vitrohm
R12	5 600 "	1/2	10	Ins. Carbon-Film SBT	"
R13	15 000 "	3	10	Wire Wound CZ 02,038	"
R14	1 200 "	3	10	" CZ 00,038	"
R15	5 "	3	10	" CZT 00,038	"
R16	1 500 "	2	10	Ins. Carbon-Film BBT	"
R17	51 "	1/2	10	Ins. Carbon-Film SBT	"
R20	30 000 "	1/2	10	Cracked-Carbon	Rosenthal SCD or NSF
R21	30 000 "	1/2	10	"	"
R101	5,1 Mohm	1/2	10	Ins. Carbon-Film SBT	Vitrohm
R102	5,1 "	1/2	10	"	"
R103	10 000 ohm	1/2	10	"	"
R104	10 000 "	1/2	10	"	"
R105	2 000 "	1	10	Cracked-Carbon	Rosenthal SCD or NSF
R106	2 000 "	1	10	"	"
R107	0,1 Mohm	1	10	"	"
R108	0,1 "	1	10	"	"
R109—R110	0,25 Mohm	1	10	Double Potentiometer T5058	Elap
R111	2 000 ohm	1/2	10	Ins. Carbon-Film SBT	Vitrohm
R112	2 000 "	1/2	10	"	"
R113	0,1 Mohm	1	10	Cracked-Carbon	Rosenthal SCD or NSF
R114	0,1 "	1	10	"	"
R115	0,25 "	1	10	Trimming Potentiometer P4	Vitrohm
R116	0,25 ohm	1/2	10	Cracked-Carbon	Rosenthal SCD or NSF
R117	20 000 "	1/2	10	"	"
R118	20 000 "	1/2	10	"	"
R119	3 900 "	1/2	10	Ins. Carbon-Film ABT	Vitrohm
R120	3 900 "	1/2	10	"	"
R121	0,1 Mohm	1	10	Ins. Carbon-Film ABT	"
R122	0,1 "	1	10	"	"
R123	0,51 "	1/2	10	Ins. Carbon-Film SBT	"
R124	0,51 "	1/2	10	"	"
R125	0,1 "	1/2	10	"	"
R126	0,1 "	1/2	10	"	"
R127	1 "	1/2	10	"	"
R128	1 "	1/2	10	"	"
R129	510 ohm	1/2	10	"	"
R130	510 "	1/2	10	Ins. Carbon-Film ABT	"
R131	82 000 "	1	10	"	"
R132	82 000 "	1	10	Ins. Carbon-Film SBT	"
R133	0,1 Mohm	1/2	10	"	"
R134	0,1 "	1/2	10	Cracked-Carbon	"
R135	10 000 ohm	1/2	10	"	"
R136	10 000 "	1/2	10	Trimming Potentiometer E097AB	Rosenthal SCD or NSF
R137	0,5 Mohm	1/2	10	"	Phillips
R138	0,5 "	1/2	10	Ins. Carbon-Film SBT	"
R201	0,1 "	1/2	10	"	Vitrohm
R202	0,1 "	1/2	10	"	"
R203	1 "	1/2	10	"	"
R204	1 "	1/2	10	"	"

R205	2 000 ohm	1	»	10	»	Cracked-Carbon	Rosenthal SCD or NSF
R206	2 000 »	1	»	10	»	»	»
R207	47 000 »	1	»	10	»	»	»
R208	47 000 »	1	»	10	»	»	»
R209	1 Mohm	$\frac{1}{2}$	»	10	»	Ins. Carbon-Film SBT	Vitrohm
R210	1 »	$\frac{1}{2}$	»	10	»	»	»
R211	1 000 ohm	$\frac{1}{2}$	»	10	»	»	»
R212	1 000 »	$\frac{1}{2}$	»	10	»	»	»
R213	0,1 Mohm	1	»	10	»	Cracked-Carbon	Rosenthal SCD or NSF
R214	0,1 »	1	»	10	»	»	»
R215	1 »	$\frac{1}{2}$	»	10	»	Ins. Carbon-Film SBT	Vitrohm
R216	1 »	$\frac{1}{2}$	»	10	»	»	»
R217	9 100 ohm	$\frac{1}{2}$	»	10	»	»	»
R218	9 100 »	$\frac{1}{2}$	»	10	»	»	»
R219	18 000 »	$\frac{1}{2}$	»	10	»	»	»
R220	18 000 »	$\frac{1}{2}$	»	10	»	»	»
R221	27 000 »	$\frac{1}{2}$	»	10	»	»	»
R222	27 000 »	$\frac{1}{2}$	»	10	»	»	»
R223	39 000 »	$\frac{1}{2}$	»	10	»	Cracked-Carbon	Rosenthal SCD or NSF
R224	39 000 »	$\frac{1}{2}$	»	10	»	»	»
R225	7 500 »	$\frac{1}{2}$	»	10	»	Ins. Carbon-Film SBT	Vitrohm
R226	7 500 »	$\frac{1}{2}$	»	10	»	»	»
R227	510 »	$\frac{1}{2}$	»	10	»	»	»
R228	510 »	$\frac{1}{2}$	»	10	»	»	»
R229	82 000 »	1	»	10	»	»	»
R230	82 000 »	1	»	10	»	Ins. Carbon-Film SBT	»
R231	0,68 Mohm	$\frac{1}{2}$	»	10	»	»	»
R232	0,68 »	$\frac{1}{2}$	»	10	»	»	»
R233	0,2 »					Trimming Potentiometer	Philips
R234	0,2 »					»	»
R235	51 000 ohm	$\frac{1}{2}$	»	10	»	Ins. Carbon-Film SBT	Vitrohm
R236	51 000 »	$\frac{1}{2}$	»	10	»	»	»
R237	1 Mohm	$\frac{1}{2}$	»	10	»	»	»
R238	1 »	$\frac{1}{2}$	»	10	»	»	»
R239	2 000 ohm	$\frac{1}{2}$	»	10	»	»	»
R240	2 000 »	$\frac{1}{2}$	»	10	»	»	»
R241	10 000 »	1	»	10	»	Cracked-Carbon	Rosenthal SCD or NSF
R242	10 000 »	1	»	10	»	»	»
R243	0,1 Mohm	$\frac{1}{2}$	»	10	»	Ins. Carbon-Film SBT	Vitrohm
R244	0,1 »	$\frac{1}{2}$	»	10	»	»	»
R245	2 000 ohm	$\frac{1}{2}$	»	10	»	Cracked-Carbon	Rosenthal SCD or NSF
R246	2 000 »	$\frac{1}{2}$	»	10	»	»	»
R301	0,5 Mohm					Trimming Potentiometer E097AC	Philips
R302	0,5 »					»	»
R303	0,12 »	$\frac{1}{2}$	»	10	»	Ins. Carbon-Film SBT	Vitrohm
R304	0,12 »	$\frac{1}{2}$	»	10	»	»	»
R305	51 ohm	$\frac{1}{2}$	»	10	»	»	»
R306	10 000 »	$\frac{1}{2}$	»	10	»	»	»
R307	10 000 »					Trimming Potentiometer E097AC	Philips
R308	10 000 »	$\frac{1}{2}$	»	10	»	Ins. Carbon-Film SBT	Vitrohm
R401	0,15 Mohm	$\frac{1}{2}$	»	10	»	»	»
R402	0,15 »	$\frac{1}{2}$	»	10	»	»	»
R403	0,15 »					Ins. Carbon-Film ABT	»
R404	0,15 »	1	»	10	»	»	»
R405	0,15 »	1	»	10	»	Ins. Carbon-Film SBT	»
R406	0,15 »	$\frac{1}{2}$	»	10	»	»	»
R407	10 »	$\frac{1}{2}$	»	10	»	»	»
R408	10 »	$\frac{1}{2}$	»	10	»	»	»

7.2.2 Capacitors.

Capacitor ID	Value	Dielectric	Material	Manufacturer
C1	10 pF	125 volts	Ceramics	Philips
C2	200 "	125 "	Styroflex	Siemens or Evox
C3	200 "	125 "	"	"
C4	10 "	125 "	"	Philips
C5	40 + 20 ÷ 10 µF	350 "	Electrolytic CE839/14	Plessey
C6	40 + 20 + 10 "	350 "	"	"
C7	40 + 20 + 10 "	350 "	"	"
C8	40 + 20 + 10 "	350 "	"	"
C9	1 000 ± 1 000 "	30/35 "	Electrolytic with Ins. Sleeve	Rifa
C10	250 "	30/35 "	Electrolytic B4101	Siemens or Evox
C11	40 + 20 + 10 "	350 "	Electrolytic CE839/14	Plessey
C12	1 000 + 1 000 "	30/35 "	Electrolytic with Ins. Sleeve	Rifa
C13	0,1 "	350 AC volts	Oil Paper CA	T.I.K.
C14	1,5 "	380/570 AC "	Oil Paper CA no. 8502 g	"
C15	10 000 pF	400 volts	Paper W99	Hunt
C16	10 000 "	400 "	"	"
C17	40 + 20 + 10 µF	350 "	Electrolytic CE839/14	Plessey
C101	25 µF	6/8 "	Electrolytic	Siemens
C102	25 "	6/8 "	"	"
C103	0,222 "	400 "	Metallized Paper, Miniprint	Rifa
C104	0,222 "	400 "	"	"
C105	4 000 pF	150 "	Paper W99	Hunt
C106	4 000 "	150 "	"	"
C107	0,047 µF	400 "	Metallized Paper, Miniprint	Rifa
C108	0,047 "	400 "	"	"
C109	16 "	350 "	Electrolytic B43291A	Siemens
C110	16 "	350 "	"	"
C111	10 000 pF	150 "	Paper W99	Hunt
C112	2 000 "	400 "	"	"
C113	10 000 "	150 "	"	"
C114	2 000 "	400 "	"	"
C115	20 000 "	150 "	"	"
C116	20 000 "	150 "	"	"
C117	0,022 µF	400 "	Metallized Paper, Miniprint	Rifa
C118	0,022 "	400 "	"	"
C119	0,047 "	400 "	"	"
C120	0,047 "	400 "	"	"
C121	100 pF	125 "	Styroflex	Siemens or Evox
C122	100 "	125 "	"	"
C123	65 "	125 "	"	"
C124	65 "	125 "	"	"
C125	"	"	"	"
C126	"	"	"	"
C127	16 µF	350 "	Electrolytic B43291A	Siemens
C128	16 "	350 "	"	"
C129	15 pF	500 "	Ceramics	Philips
C130	15 "	500 "	"	"
C131	25 µF	6/8 "	Electrolytic	Siemens
C132	25 "	6/8 "	"	"
C133	0,047 "	400 "	Metallized Paper, Miniprint	Rifa
C134	0,047 "	400 "	"	"
C201	200 pF	125 "	Styroflex	Siemens or Evox
C202	200 "	125 "	"	"
C203	1 500 "	400 "	Paper W99	Hunt
C204	1 500 "	400 "	"	"

1) C5, C6 and C17 in the same can.  
2) C7, C8 and C11 in the same can.

C205	0,022 $\mu$ F	400	»		Metalized Paper, Miniprint	Rifa
C206	0,022 »	400	»		—»—	»
C207	25 »	6/8	»		Electrolytic	Siemens
C208	25 »	6/8	»		»	»
C209	0,022 »	400	»		Metalized Paper, Miniprint	Rifa
C210	0,022 »	400	»		—»—	»
C211	0,047 »	400	»		—»—	»
C212	0,047 »	400	»		—»—	»
C213	16 »	350	»		Electrolytic B43291A	Siemens
C214	16 »	350	»			
C215	500 pF	600	»	10 %	Paper W99	Hunt
C216	500 »	600	»	10 »	»	»
C217	0,047 $\mu$ F	400	»		Metalized Paper, Miniprint	Rifa
C218	0,047 »	400	»		»	»
C219	5 000 pF	150	»	10 »	Paper W99	Hunt
C220	5 000 »	150	»	10 »	»	»
C221	0,022 $\mu$ F	400	»		Metalized Paper, Miniprint	Rifa
C222	0,022 »	400	»		—»—	»
C223	16 »	350	»		Electrolytic B43291A	Siemens
C224	16 »	350	»		—»—	»
C225	2 »	70/80	»		—»—	»
C226	2 »	70/80	»		—»—	»
C227	10 000 pF	150	»		Paper W99	Hunt
C228	10 000 »	150	»		»	»
C301	65 »	500	»	5 %	Styroflex	Siemens or Evox
C302	0,01 $\mu$ F	400	»		Metalized Paper, Miniprint	Rifa
C303	65 pF	500	»	5 %	Styroflex	Siemens or Evox
C304	0,1 $\mu$ F	400	»		Metalized Paper, Miniprint	Rifa
C305	125 pF	125	»	5 %	Styroflex	Siemens or Evox
C306	125 »	125	»	5 »	»	—»—
C307	50—200 »				Glimmer Trimming Cond.	Cylden Sidney Bird
C308	0,047 $\mu$ F	400	»		Metalized Paper, Miniprint	Rifa
C310	2 000 pF	500	»	2,5 %	Styroflex	Siemens or Evox
C311	5 000 »	125	»	2,5 »	»	—»—
C312	2 000 »	500	»	2,5 »	»	—»—
C401	0,01 $\mu$ F	400	»		Metalized Paper, Miniprint	Rifa
C402	0,01 »	400	»		»	»
C405	0,022 »	400	»		—»—	»
C406	0,022 »	400	»		—»—	»

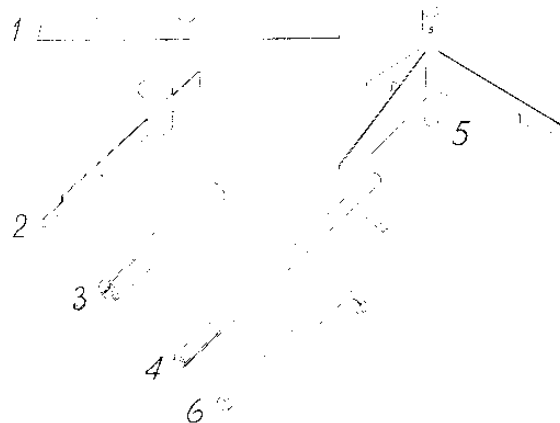

Fig. 32. Special Tools

MODES OF OPERATION		SETTINGS			REMARKS
OPERATION	CATHODE FOLLOWER OUTPUTS	SOUND ON-SOUND SWITCH	PUSH BUTTONS		
			CHANNEL 1	CHANNEL 2	
MONO RECORD, mixed inputs	No output.	NORMAL			If the preamp and the poweramp are NOT separated, howling may occur. To prevent this, turn the playback volume control(s) off (or low) for recording and the record gain control(s) off for playback.
	B test. Same output of both cathode followers.	NORMAL			
	AB-test. Same output of both cathode followers	AB-TEST	B A		
MONO PLAYBACK	Same output of both cathode followers.	NORMAL			Operating lever in Normal Forward Drive position.
MONO PREAMP	Same output of both cathode followers.	AB-TEST			
STEREO RECORD	No output.	NORMAL			If the preamp and the poweramp are NOT separated, howling may occur. To prevent this, turn the playback volume control(s) off (or low) for recording and the record gain control(s) off for playback.
	B-test. Stereo output.	NORMAL			
	AB-test. Stereo output.	AB-TEST	B A		
STEREO PLAYBACK	Stereo output.	NORMAL			
STEREO PREAMP	Stereo output.	AB-TEST			Tape stopped.
MONO PLAYBACK-MONO RECORD	B test in one channel. Mono playback in the other.	NORMAL			The cathode follower for the master track is connected to the high level input of the same channel. (For Ch. 1 master track on upper track, and Ch. 2 on lower track.)
SOUND-ON-SOUND	A test.	S-on-S			*
	B test.	S on S			

\* In Sound-on-Sound playback is made with pushbuttons IV and V depressed.

Fig. 33. Preferred Push-Button Combinations

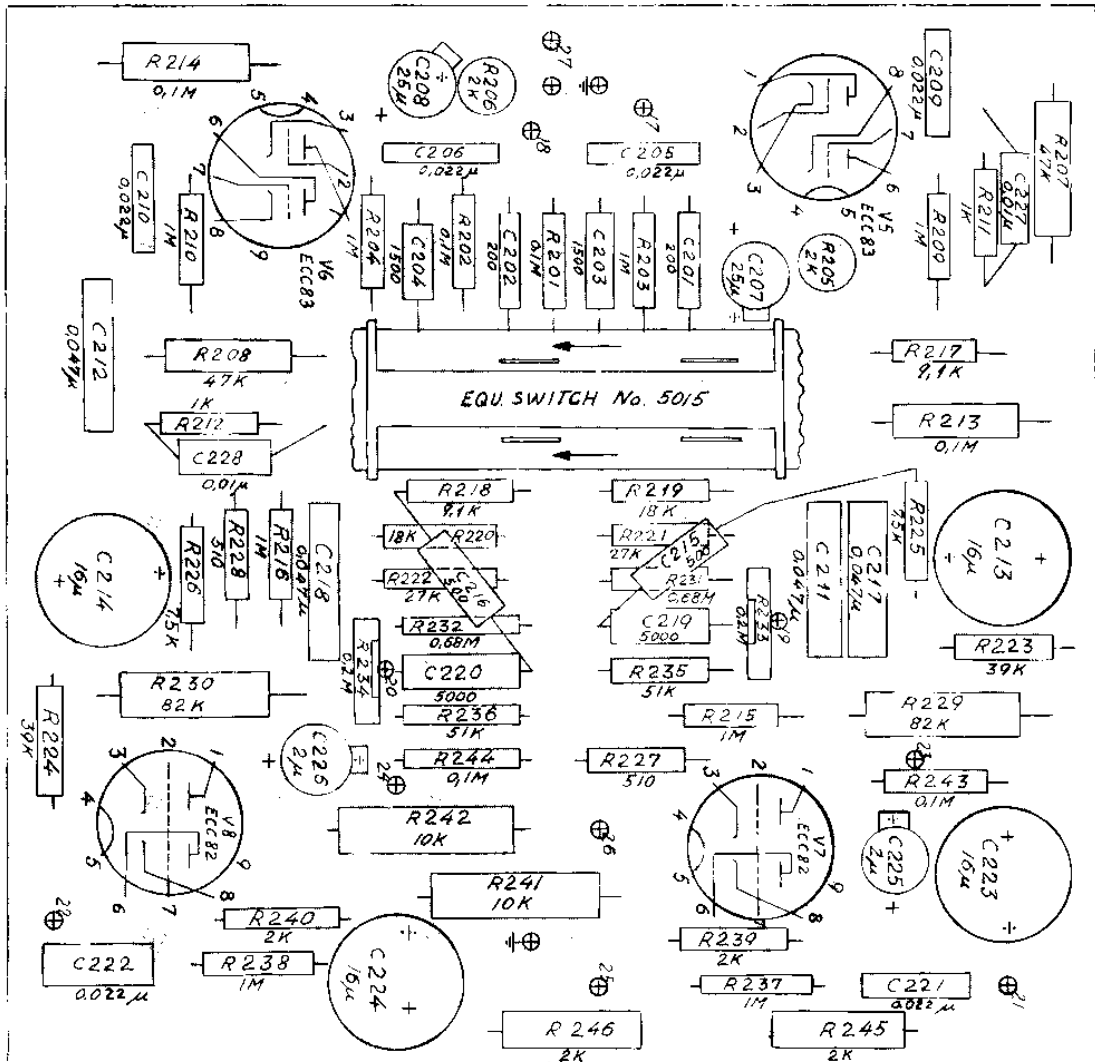

Fig. 34. Playback Amplifier Board, No. 5006





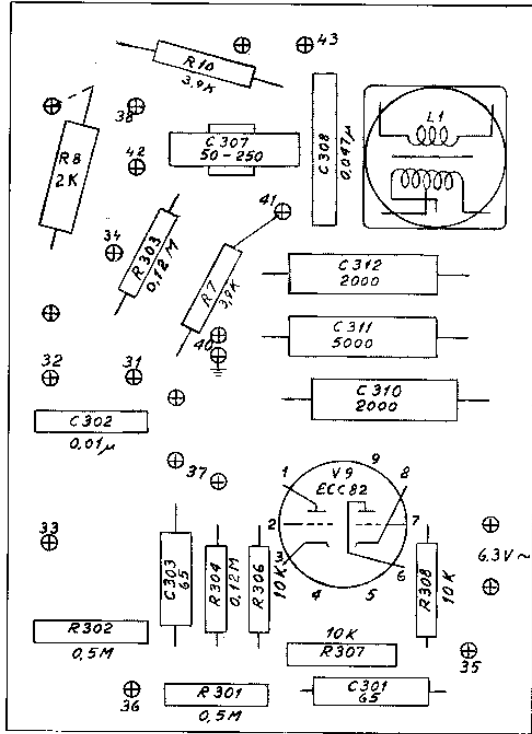

Fig. 36. Oscillator Board, No. 5113

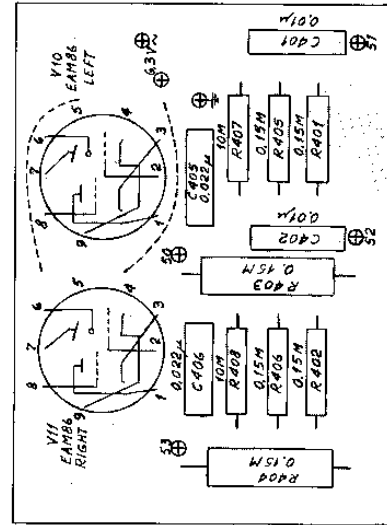
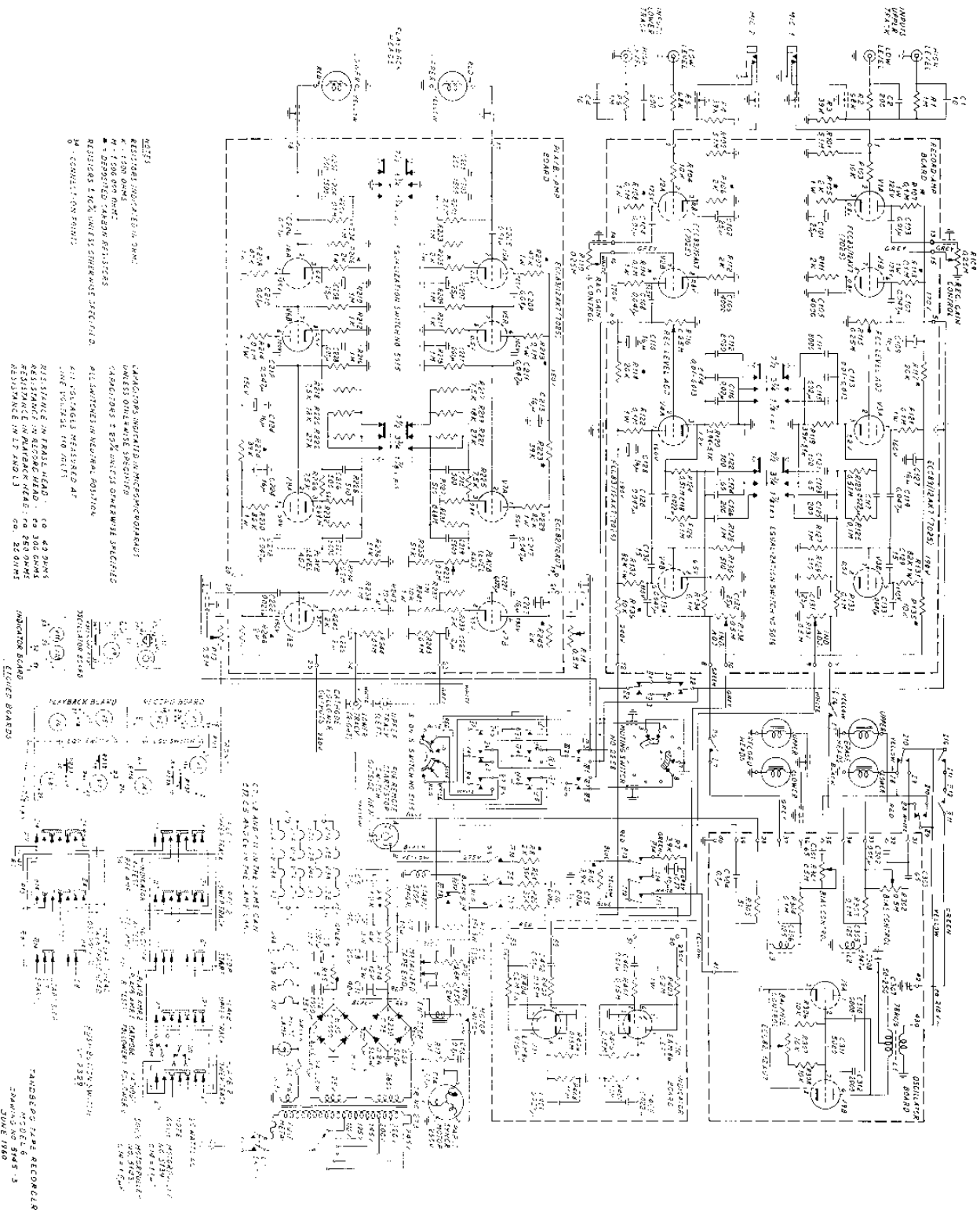

Fig. 37. Indicator Board, No. 2363

Fig. 38. Complete Circuit Diagram for Serial No. 602700-606200



**NOTES**

RESISTORS INDICATED IN SCHEMATIC DIAGRAMS UNLESS OTHERWISE SPECIFIED ARE 1/2 WATT 5% TOLERANCE CARBON RESISTORS RESISTORS WITH UNITS SHOWN ARE OF THE 1% CONNECTION POINT

CAPACITORS INDICATED IN SCHEMATIC DIAGRAMS UNLESS OTHERWISE SPECIFIED ARE 50VDC 5% TOLERANCE CERAMIC CAPACITORS 250VDC UNITS OTHERWISE SPECIFIED ARE 50VDC 5% TOLERANCE ELECTROLYTIC CAPACITORS

ALL VOLTAGES MEASURED AT LINE VOLTAGE TO GROUND

ALL STANDBY IN TAPES HEAD - 60 40 30VMS RESISTANCE IN RECORD HEAD - 60 300 OHMS RESISTANCE IN PLAYBACK HEAD - 60 250 OHMS RESISTANCE IN ST AND LS CO. 20 OHMS

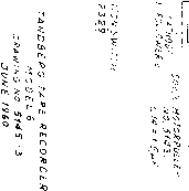
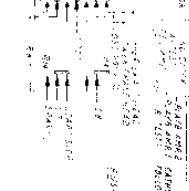
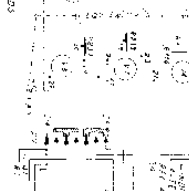

MANUFACTURED BY  
 MODEL 6  
 SERIAL NO. 602700-606200  
 DATE 1950

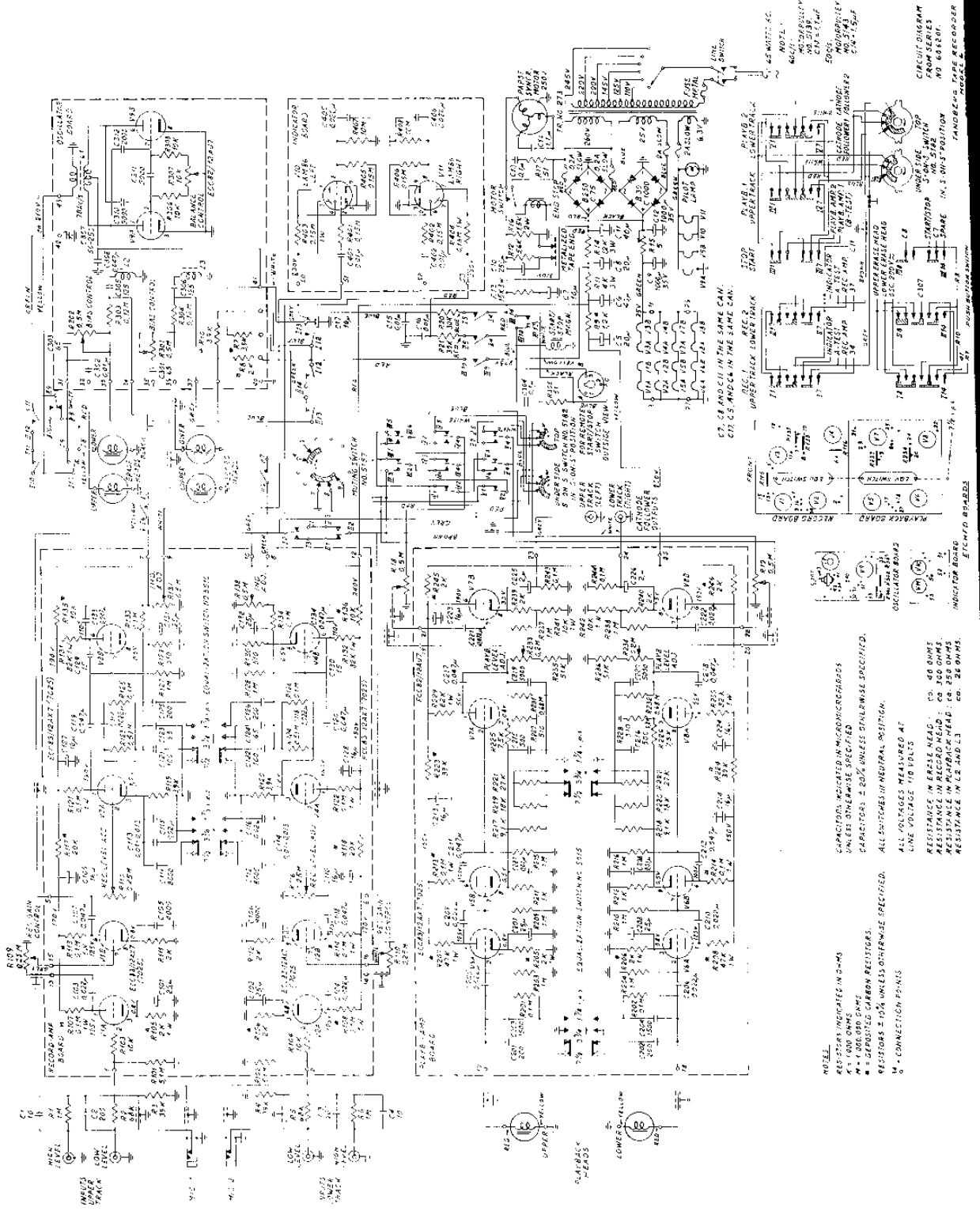
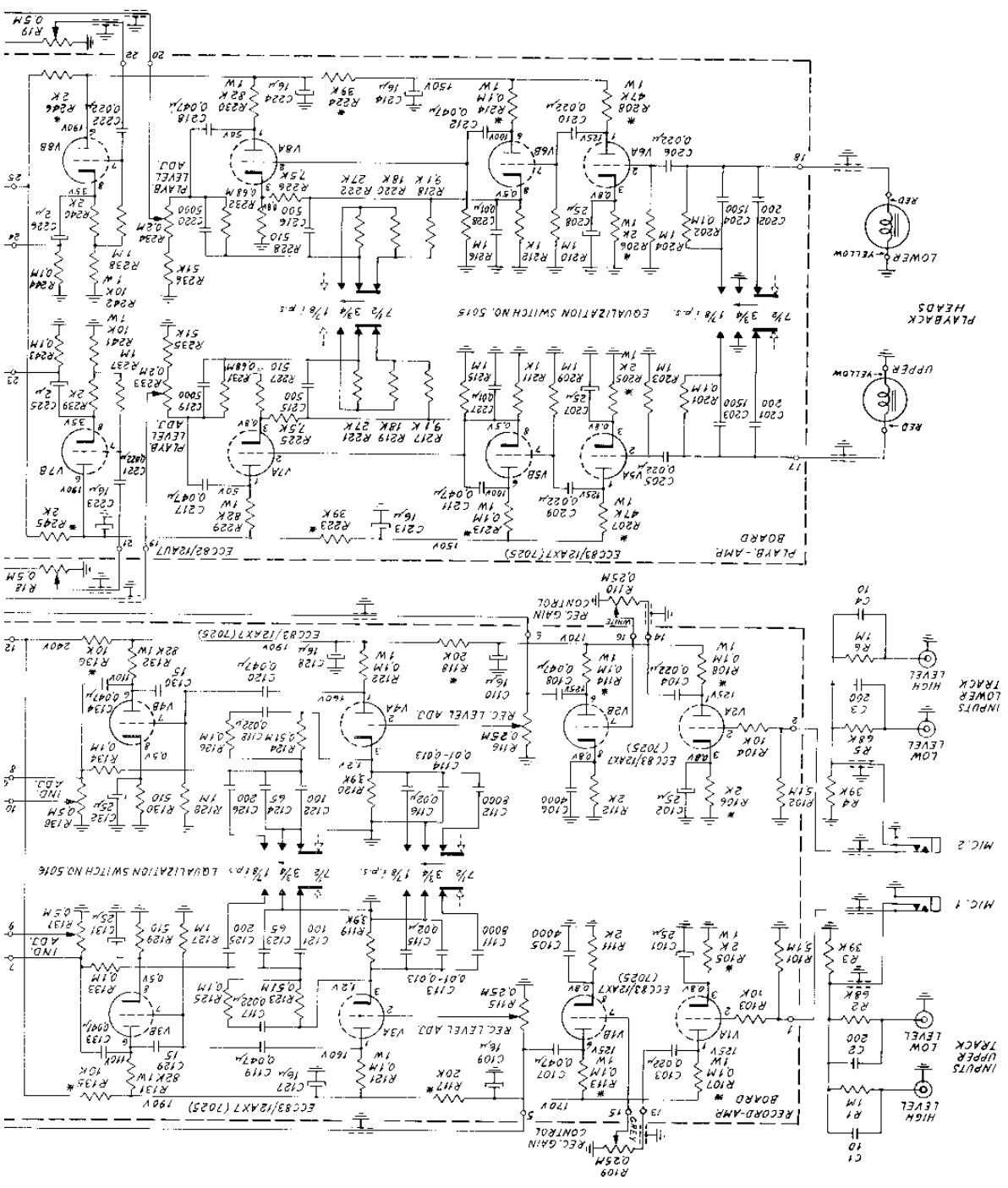

Fig. 39. Complete Circuit Diagram for Serial No. 606 201-607 500



RESISTORS INDICATED IN OHMS.  
 K = 1,000 OHMS.  
 M = 1,000,000 OHMS.  
 \* = DEPOSITED CARBON RESISTORS.  
 RESISTORS ± 10% UNLESS OTHERWISE SPECIFIED.  
 ALL SWITCHES IN NEUTRAL POSITION.  
 ALL VOLTAGES MEASURED AT  
 LINE VOLTAGE 110 VOLTS.  
 RESISTANCE IN ERASE HEAD: CA. 40 OHMS  
 RESISTANCE IN RECORD HEAD: CA. 300 OHMS  
 RESISTANCE IN PLAYBACK HEAD: CA. 250 OHMS  
 CA. 20 OHMS

NOTES:  
 RESISTORS INDICATED IN OHMS.  
 K = 1,000 OHMS.  
 M = 1,000,000 OHMS.  
 \* = DEPOSITED CARBON RESISTORS.  
 RESISTORS ± 10% UNLESS OTHERWISE SPECIFIED.  
 ALL SWITCHES IN NEUTRAL POSITION.  
 ALL VOLTAGES MEASURED AT  
 LINE VOLTAGE 110 VOLTS.  
 RESISTANCE IN ERASE HEAD: CA. 40 OHMS  
 RESISTANCE IN RECORD HEAD: CA. 300 OHMS  
 RESISTANCE IN PLAYBACK HEAD: CA. 250 OHMS  
 CA. 20 OHMS



PLAYBACK-AMP BOARD  
 ECC83/12AX7 (7025)  
 MIC. 1  
 MIC. 2  
 UPPER TRACK  
 LOWER TRACK  
 HIGH LEVEL  
 LOW LEVEL  
 REC. GAIN CONTROL  
 CONTROL



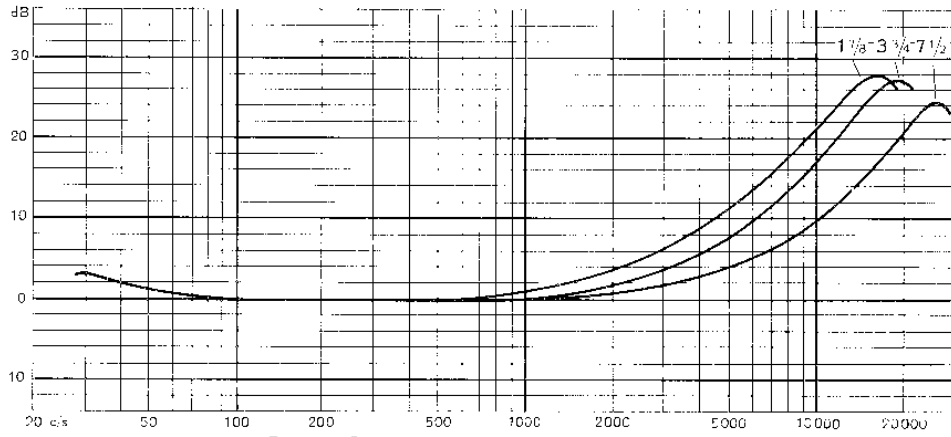

Fig. 40. Recording Amplifier Response Curves.

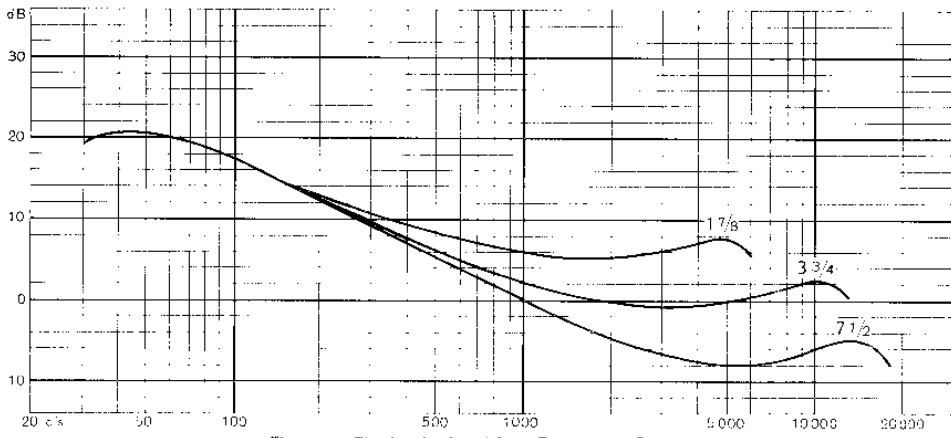

Fig. 41. Playback Amplifier Response Curves.



DANL. MATHISEN & CO. S TRYKK

Printed in Norway