

# TANDBERG

Series 2000

# SERVICE MANUAL

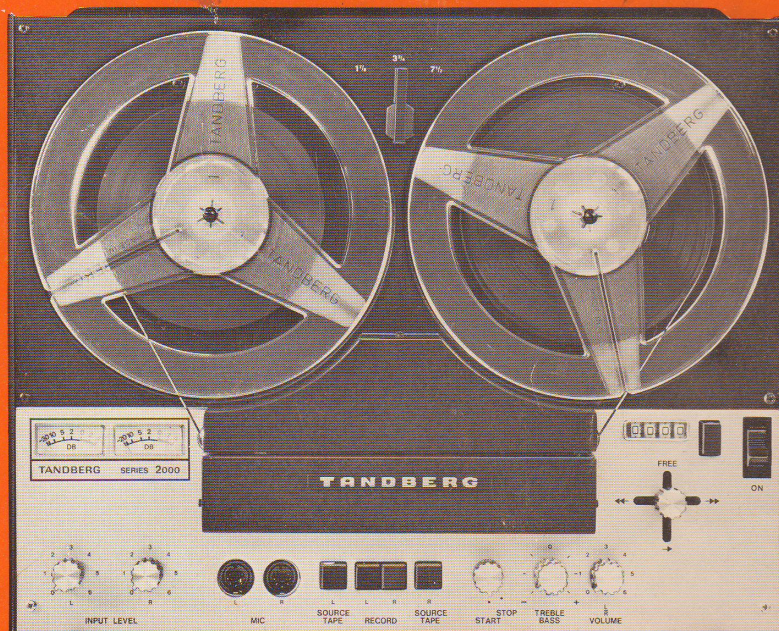

TANDBERGS RADIOFABRIKK A/S



## GENERAL INFORMATION

- Use only Low Noise Tape for recording. A good head-to-tape contact is essential for obtaining satisfactory frequency response and signal/noise ratio. In order to obtain the best possible results with new tapes, these should be run through approximately 5 times in drive mode in order to polish the surface of the tape. Always check that heads and tape guides are clean. For cleaning purposes, use a special liquid such as Tandberg Professional Tape Head Cleaner or pure alcohol or benzine.
  - In order to make magnetized parts of the tape visible, dip the tape in "Magna-See", a mixture of iron oxide powder and alcohol. Iron oxide powder can be obtained from our service department.
  - Heads, tape guides and capstan must be degaussed both before and after adjustment of heads and tape guides. Move the degausser slowly past the head gaps at a very short distance, but without touching the heads. Then hold the degausser close to the capstan for a few seconds. Start the tape recorder and hold the degausser just above the flywheel.
- NOTE: Do not switch off the degausser until it is at a distance of about 1 meter from the tape recorder.

- Perform the adjustments in the same sequence as explained, because some of the adjustment procedures assume that the previous adjustments have already been performed. If not otherwise specified, make all adjustments at 7 1/2 ips.
- For checking and adjustments of heads and tape guides, only the head covers need to be removed. For electrical adjustments also the cabinet and the bottom cover must be detached. Removal of the top plate will usually only be necessary for checking and adjustments of clutches and other parts in the drive mechanism.

### Removal of Cabinet and Bottom Cover

The cabinet is attached with 6 screws, 2 on each side and 2 on the front. When these are unscrewed, pull the cabinet off the chassis towards the front. Removal of the cabinet is unaffected by the top and bottom covers.

The bottom cover is attached with 6 screws which must be unscrewed before removal.

### Removal of Top Plate

Remove the speed selector knob, knobs for input level, volume, bass and treble, and the knob on the operating lever. The knobs are retained by springs and can be pulled straight off. Also remove the head covers. Unscrew the 10 screws shown in fig. 1. Two of the screws also hold the mounting brackets for the front head cover. Pull the black lists on the side out to the sides and remove the front and rear halves of the top cover. Be careful not to disturb the end stop sensor.

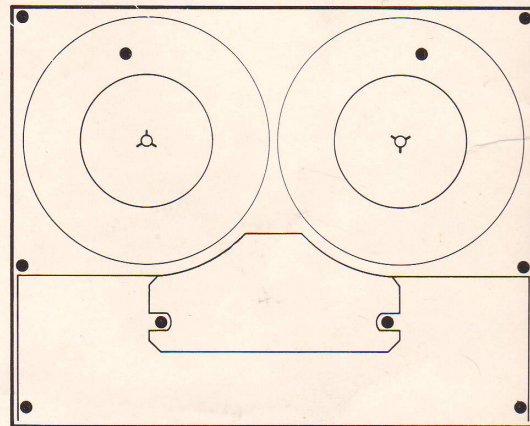

Fig. 1 Top plate screws.

## OBSERVE

IN ANY COMMUNICATION PERTAINING TO THE EQUIPMENT, PLEASE SPECIFY TYPE AND SERIAL NUMBER

## WARNING

The nickelplated screws intended for mounting of extra legs for vertical operation of the tape recorder, must not be used except when the legs are mounted on the tape recorder. Otherwise the screws may cause short-circuiting on the main component board and may even damage the board.



# TABLE OF CONTENTS

<p>1.0 TECHNICAL SPECIFICATIONS ..... 2</p> <p>2.0 MECHANICAL ADJUSTMENTS AND CHECKING ..... 4</p> <p>  2.1 Clutches ..... 4</p> <p>    2.1.1 Checking of Clutch Torque ..... 4</p> <p>    2.1.2 Take-up Turntable ..... 5</p> <p>    2.1.3 Supply Turntable ..... 5</p> <p>  2.2 Brakes ..... 5</p> <p>  2.3 Tape Path ..... 6</p> <p>    2.3.1 End-stop Mechanism ..... 6</p> <p>    2.3.2 Capstan ..... 6</p> <p>    2.3.3 Preliminary Adjustment of the Tape Guide Posts ..... 7</p> <p>    2.3.4 Heads ..... 7</p> <p>    2.3.5 Pressure Pad ..... 8</p> <p>    2.3.6 Pinch Roller ..... 8</p> <p>    2.3.7 Inertia Idling Roller ..... 9</p> <p>    2.3.8 Checking and Readjustment of the Tape Guide Posts ..... 9</p> <p>3.0 ELECTRICAL CHECKS AND ADJUSTMENTS ..... 9</p> <p>  3.1 Erase- and Bias Circuits ..... 9</p> <p>    3.1.1 Oscillator Frequency ..... 9</p> <p>    3.1.2 Checking of the Erase Voltage ..... 9</p> <p>  3.2 Lubrication ..... 9</p> <p>3.0 ELECTRICAL CHECKS AND ADJUSTMENTS ..... 9</p> <p>  3.1 Erase- and Bias Circuits ..... 9</p> <p>    3.1.1 Oscillator Frequency ..... 9</p> <p>    3.1.2 Checking of the Erase Voltage ..... 9</p> <p>  3.2 Head Alignment - 2-track Models ..... 10</p> <p>    3.2.1 Playback Head ..... 10</p> <p>    3.2.2 Record Head ..... 11</p> <p>    3.2.3 Erase Head ..... 11</p> <p>    3.2.4 Alignment of Hum Shield for the Playback Head ..... 11</p> <p>  3.3 Head Alignment - 4-track Models ..... 12</p> <p>    3.3.1 Playback Head ..... 12</p> <p>    3.3.2 Record Head ..... 12</p> <p>    3.3.3 Erase Head ..... 13</p> <p>    3.3.4 Alignment of Hum Shield for the Playback Head ..... 13</p>	<p>  3.4 Adjustment of Amplifiers ..... 13</p> <p>    3.4.1 Playback Level ..... 13</p> <p>    3.4.2 Bias ..... 13</p> <p>    3.4.3 Adjustment of Record Level ..... 13</p> <p>    3.4.4 Checking of the Frequency Response ..... 14</p> <p>    3.4.5 Adjustment of Record Level Indicators ..... 14</p> <p>  3.5 Checking of Equalizing Amplifiers ..... 14</p> <p>    3.5.1 Checking of Playback Amplifiers Using Test Tape ..... 14</p> <p>    3.5.2 Checking the Playback Equalizing Curves ..... 14</p> <p>    3.5.3 Checking the Record Equalizing Curves ..... 15</p> <p>  3.6 Output Amplifiers ..... 16</p> <p>    3.6.1 Quiescent Current ..... 16</p> <p>    3.6.2 Checking of Distortion ..... 16</p> <p>  3.7 Tone Controls ..... 16</p> <p>  3.8 Checking of Tape Speed ..... 16</p> <p>    3.8.1 Using a Known Length of Tape ..... 16</p> <p>    3.8.2 Using Transformer and AC Voltmeter ..... 16</p> <p>    3.8.3 Using Frequency Meter or Counter ..... 16</p> <p>4.0 MODIFICATIONS ..... 17</p> <p>  4.1 Modifications for a Different Line Voltage and Frequency ..... 17</p> <p>  4.2 Modification 2-Track/4-Track ..... 17</p> <p>5.0 ILLUSTRATIONS WITH PART NUMBERS ..... 18</p> <p>6.0 SPARE PARTS LIST ..... 24</p> <p>  6.1 Mechanical Parts ..... 24</p> <p>    6.1.1 Screws, Washers, Nuts, and Circlips ..... 27</p> <p>  6.2 Electrical Parts ..... 28</p> <p>    6.2.1 Resistors ..... 28</p> <p>    6.2.2 Capacitors ..... 30</p> <p>    6.2.3 Potentiometers ..... 31</p> <p>    6.2.4 Transistors ..... 31</p> <p>    6.2.5 Heads ..... 32</p> <p>    6.2.6 Diodes ..... 32</p> <p>7.0 BLOCK DIAGRAM ..... 33</p> <p>8.0 PRINTED WIRING BOARDS AND CIRCUIT DIAGRAM ..... 33</p>
--	---



## 1.0 Technical Specifications

MAINS VOLTAGE:	Standard model: 230 V/50 Hz. Can be rewired for 115 or 240 V. U.S. model: 115 V/60 Hz. Can be rewired for 220 or 240 V.
POWER CONSUMPTION:	Maximum 90 watts.
MOTOR:	2-pole asynchronous.
TAPE:	Maximum reel diameter: 7". Low Noise Tape must be used for adjustments.
TAPE SPEED:	7 1/2, 3 3/4, 1 7/8 ips.
SPEED TOLERANCE:	1.0 %.
FAST FORWARD AND REVERSE WINDING:	1200 ft tape, 7" reel: 1 min. 45 sec. 1800 ft tape, 7" reel: 2 min. 10 sec.
HEADS:	Erase head, record head, and playback head.
ERASE AND BIAS FREQUENCY:	85.5 kHz. Distortion less than 0.5 %.
RECORD LEVEL INDICATOR:	Moving coil instrument showing peak value. Deflection to 0 dB corresponds to 3 % tape distortion.
INPUTS:	Each channel has the following inputs: <ol style="list-style-type: none"><li>1. Microphone input, unbalanced (MIC, DIN-socket), for dynamic microphone with impedance lower than 700 ohms. Sensitivity at 400 Hz: 50 <math>\mu</math>V. Maximum input level: 5 V.</li><li>2. Line input (RADIO, DIN-socket). Impedance: 50 kohms. Sensitivity at 400 Hz: 5 mV. Maximum input level: 10 V.</li><li>3. Pick-up input (PHONO, DIN-socket) for ceramic/crystal pick-up. Impedance: 1 Mohm. Sensitivity: 100 mV.</li></ol>
OUTPUTS:	Each channel has the following outputs: <ol style="list-style-type: none"><li>1. Speaker output (LOUDSPEAKERS 4 OHMS, DIN-socket). Speaker impedance: 4 - 8 ohms. Maximum output power: 6 watts of continuous sinusoidal power from each channel.</li><li>2. Line output (RADIO, DIN-socket). Minimum load impedance: 200 ohms. Output level, unloaded: 0.75 V for a tape with a 400 Hz signal recorded at 0 dB deflection on the record indicator.</li></ol>
SPEAKERS:	Internal speakers: 4" x 7", impedance 8 ohms.
BASS AND TREBLE CONTROLS:	The bass and treble controls are continuously variable, and affect programmes fed to speakers or headphones only. The bass and treble controls are common for the two channels. Bass: + 10 dB at 50 Hz. Treble: $\pm$ 10 dB at 10 000 Hz.
TRANSISTORS:	41.
DISTORTION:	From record amplifier, at 400 Hz and 0 dB level: 0.5 %. From playback amplifier, at 0.75 V playback



TRANSISTORS: 41.

DISTORTION: From record amplifier, at 400 Hz and 0 dB record level: 0.5 %.  
From playback amplifier, at 0.75 V playback level: 0.3 %.

TAPE DISTORTION: From a tape recorded at 400 Hz and 0 dB record level during playback: 3 % distortion  
From a tape recorded at 400 Hz and - 8 dB record level during playback: 0.8 % distortion

WOW: Wow, maximum R. M. S. According to DIN 45511 (peak):  
7 1/2 ips: 0.07 % 7 1/2 ips: 0.1 %  
3 3/4 ips: 0.14 % 3 3/4 ips: 0.2 %  
1 7/8 ips: 0.28 % 1 7/8 ips: 0.4 %

CROSSTALK SUPPRESSION: Measured at 1000 Hz, according to DIN 45511:  
Mono: 60 dB Stereo: 50 dB

FREQUENCY RESPONSE: Referred to 400 Hz: According to DIN 45511:  
7 1/2 ips: 40 - 18.000 Hz  $\pm$  2 dB 7 1/2 ips: 40 - 20.000 Hz  
3 3/4 ips: 50 - 12.500 Hz  $\pm$  2 dB 3 3/4 ips: 40 - 15.000 Hz  
1 7/8 ips: 60 - 6.500 Hz  $\pm$  2 dB 1 7/8 ips: 40 - 7.500 Hz  
In amplifier mode: 30 - 18.000 Hz  $\pm$  3 dB

SIGNAL/TAPE NOISE, WEIGHTED (Geräuschspannung): Peak value, measured according to DIN 45511 at 7 1/2 ips and 5 % tape distortion.  
4-track 2-track  
52 dB 54 dB

SIGNAL/TAPE NOISE, WEIGHTED (IEC A-curve) R. M. S. : At 7 1/2 ips and 5 % tape distortion.  
4-track 2-track  
60 dB 62 dB

SIGNAL/TAPE NOISE: LINEAR R. M. S. At 7 1/2 ips and 5 % distortion.  
4-track 2-track  
55 dB 55 dB

SIGNAL/TAPE NOISE: LINEAR (Fremdspannung): Peak value, measured according to DIN 45511 at 7 1/2 ips and 5 % tape distortion.  
4-track 2-track  
50 dB 50 dB

NOTE: At 3 % tape distortion all signal/tape noise measurements are reduced with 2 dB.

DIMENSIONS: Length: 15 1/2" (39.4 cm). Height: 6 1/2" (16.5 cm).  
Depth: 12 3/8" (31.8 cm).

WEIGHT: 20 lbs (9.5 kg).



## 2.0 Mechanical Adjustments and Checking

### 2.1 Clutches

#### 2.1.1 Checking of Clutch Torque

All measurements should be done with empty reels and with the tape recorder operating in horizontal position. Fig. 2.1 shows alternative measuring methods.

When using alternative A, wrap a short piece of tape on a reel with a core diameter of 60 mm (measurement radius 30 mm). In the free end of the tape, arrange a loop for the gauge arm. In alternative B, use an empty reel with a hole for the gauge drilled at 80 mm radius.

**NOTE:** During normal operating conditions the bearing friction will add to or be subtracted from the torque, depending on the direction of the rotation. When measuring small forces as for instance in row 1 and row 2 in table 2.2, the reel should be allowed to rotate slowly in the direction of the clutch torque while the measurement is performed, in order to obtain the specified values.

When using spring gauges manufactured by Halda, the gauge arm and not the housing must be perpendicular to the direction of the force (see figure).

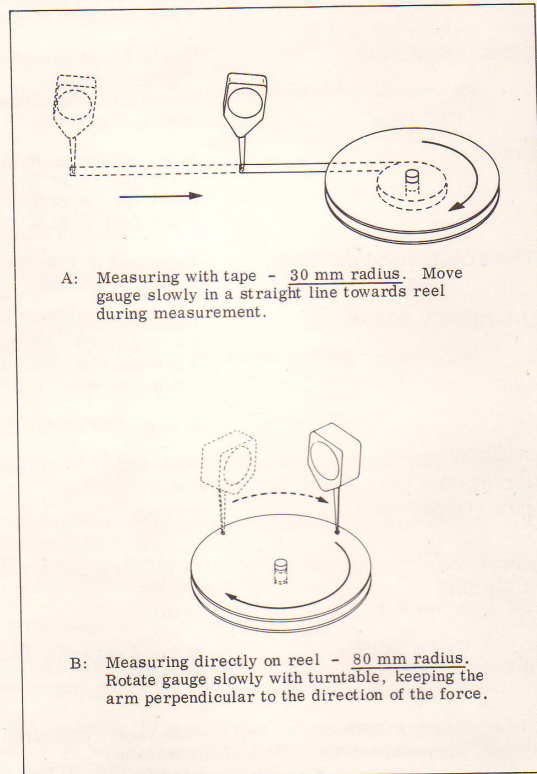

Fig. 2.1 Checking of clutch torque (shown for left turntable). Specifications: See fig. 2.2.

	Right/ Left	Lever position	Force with 30 mm radius	Force with 80 mm radius
Row 1 Take-up	R	→	40g— 80g*	15g— 30g*
Row 2 Tape tension	L	→	0 — 22g	0 — 8g
Row 3 Winding torque	R	→→	240g—670g	90g—250g
	L	←←		

\* It is normal that the winding force increases by 20 - 30 % after some time of continuous operation.

Fig. 2.2 Clutch torque specifications.



### 2.1.2 Take-up Turntable

#### Normal Forward Drive:

Remove all top covers. Set the operating lever in position Normal Forward Drive. Push the tape sensor 242503 through right hand tape guide post and secure the sensor in this position by a piece of paper in order to keep the motor switched on. Sight horizontally underneath the turntables and check that the distance between the brake pads underneath the turntable 991048 and the friction wheel 991009 is 0.5 - 0.9 mm (0.02" - 0.035"). If necessary, adjust the screw A as shown in fig. 2.3. The take-up force to be obtained can be found in table 2.2, row 1.

#### Fast Forward Winding:

The forward winding torque can be found from table 2.2, row 3. If the force departs from the specifications given in the table, check that the tension of spring 267373B is correct. Change the spring if necessary. Furthermore, check that there is a clearance of minimum 0.1 mm (0.004") between the studs on the bushing 264083A and the arm 991013. See fig. 2.4.

### 2.1.3 Supply Turntable

#### Tape Tension:

The correct tape tension can be found in table 2.2, row 2.

#### Fast Rewind:

The rewind force can be found in table 2.2, row 3. If the force departs from the specifications given in the table, the tension of spring 261805A must be altered (see fig. 2.5) or the spring must be replaced. The difference between the forces measured in Fast Forward Winding and Fast Rewinding should be less than 130 g (measured at 30 mm radius), or 50 g (measured at 80 mm radius). If the difference exceeds these values, the tension of spring 261805A or 267373B must be altered.

It can also be checked that the forces are sufficient by operating the tape recorder in vertical position with a full 7" reel on the take-up turntable.

## 2.2 Brakes

See fig. 2.6.

Set the operating lever to position Normal Forward Drive. Check that the clearance between the brake pad and the turntable is approximately 1 mm (0.04"). If necessary, adjust screw D.

Set the operating lever to Fast Forward Winding, alternatively Fast Rewinding. Check that the clearance between screw C and the moving delrin part (991017) on the operating lever is 0.5 - 1 mm (0.02" - 0.04"). Adjust screw C if necessary.

The adjustments are the same for both turntables.

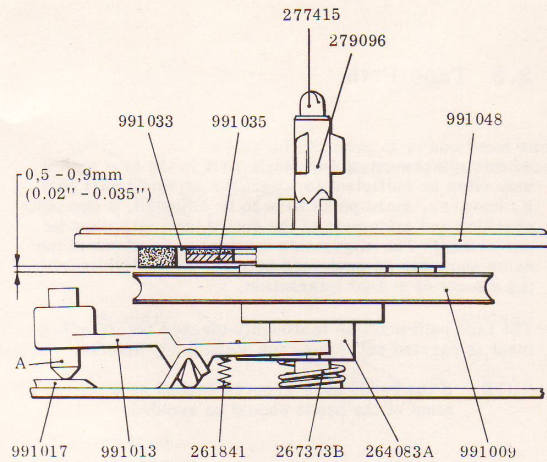

Fig. 2.3 Right turntable, operating lever in drive position.

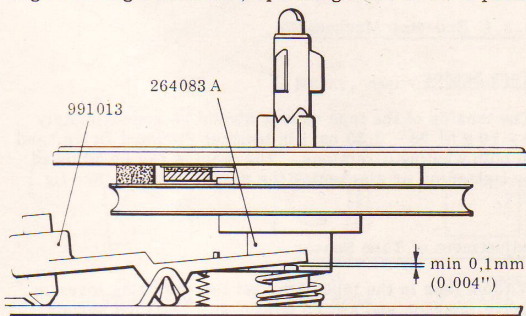

Fig. 2.4 Right turntable, operating lever in forward winding position. Clearance between tube 264083A and lever 991013.

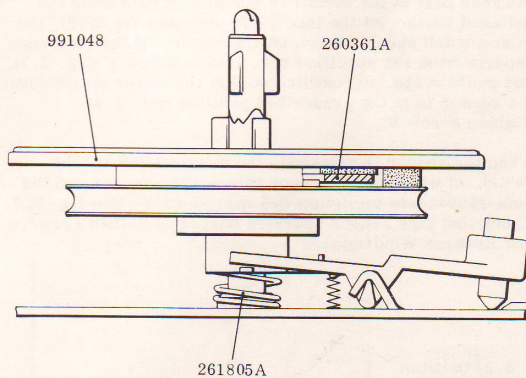

Fig. 2.5 Left turntable, operating lever in reverse winding.

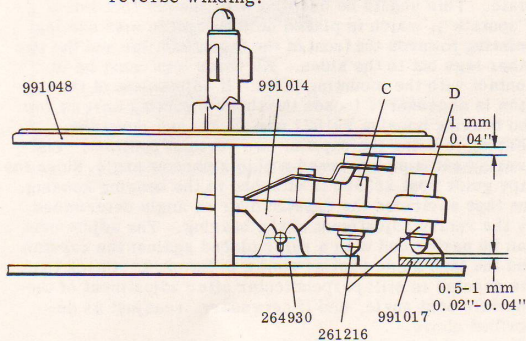

Fig. 2.6 Brake adjustment (shown for right turntable).



## 2.3 Tape Path

After replacement of one single part in the tape path it may often be sufficient to adjust the replaced part only. If, however, more parts have to be adjusted, a complete checking and alignment of the entire tape path must be performed. The alignments must be carried out in the same sequence as explained below in order to eliminate the effects of mutual interaction.

The tape path must be thoroughly cleaned before adjustment is carried out. Use tape without any defects.

NOTE: If the heads have grooves caused by wear, alignment of the heads should be avoided.

### 2.3.1 End-stop Mechanism

#### Tape Sensor

The tension of the tape sensor should be approximately 8 - 10 g (0.28 - 0.35 oz.) in Normal Forward Drive, and in both winding directions. The tension can be adjusted by tightening or slackening the spring 243990. See fig. 2.7.

#### Adjustment of Tape Sensor

Without tape in the tape path, set the operating lever in Drive position and switch power on. The tape sensor will rest in the innermost position with the motor switched off by the microswitch 202151. Push the sensor 242503 carefully through the tape guide post. When the rear part of the sensor is 0.5 mm (0.02") from the polished surface of the tape guide post (see fig. 2.8), the microswitch should switch on the motor. If the clearance departs from the specified one, loosen screw F (fig. 2.7), and position the microswitch so that the motor starts when the sensor is in the prescribed position (fig. 2.8). Tighten screw F.

When the sensor is released, the microswitch should switch off when the clearance between the sensor and the arm 266741A is minimum 0.5 mm (0.02"). See fig. 2.7. Check that tape sensor operates correctly in both Forward and Reverse Winding.

### 2.3.2 Capstan

The capstan should be perpendicular to the upper mounting plate. This should be checked with special tool No. 5 ("sputnik"), which is placed on the capstan with one leg pointing towards the front of the tape recorder and the two other legs out to the sides. All three legs must be in contact with the mounting plate. If adjustment of the capstan is necessary, loosen the three mounting screws for the bearing housing 991027 (fig. 2.7), and move the bearing to bring the capstan into vertical position. The bearing can also be turned within a narrow angle. Since the tape guide post 283522 is attached to the bearing housing, the tape encircles the capstan over an angle determined by the rotary adjustment of the bearing. The adjustment can be performed with a ruler placed against the capstan and the tape guide post as shown in fig. 2.9. Check that the capstan is still perpendicular after adjustment of the encirclement angle, and if necessary, readjust as described above.

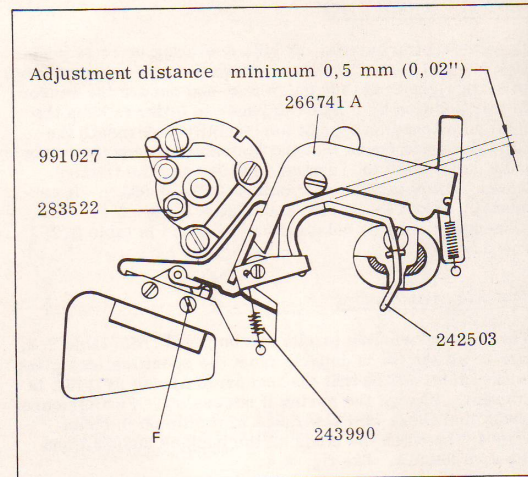

Fig. 2.7 Checking of tape sensor and adjustment of microswitch. Switch-off point for motor current.

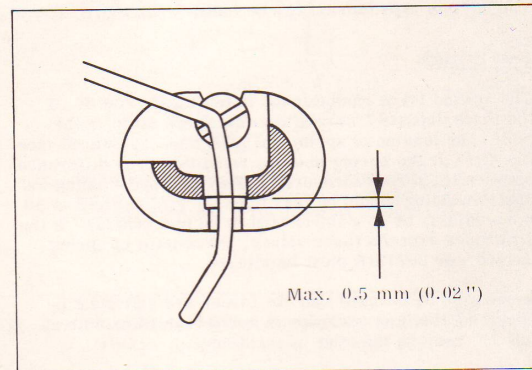

Fig. 2.8 Checking of tape sensor. Switch-on point for motor.

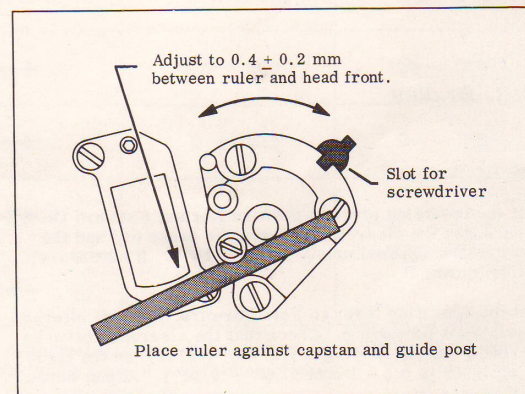

Fig. 2.9 Adjustment of tape encircling.



### 2.3.3 Preliminary Adjustment of the Tape Guide Posts

The height position of the tape guide post 5 (fig. 3.2) is fixed and should ordinarily not need any adjustments.

The tape guide posts 2, 3 and 4 should be aligned in the sequence in which they were just mentioned. They are correctly aligned when the tape enters smoothly in between the flanges, when the operating lever is moved to the Drive position. When performing this check, the tape must be tight and be placed in the tape guides on the outer fixed tape guide post. Adjust without tape movement.

### 2.3.4 Heads

Out of all the head adjustments, it is only the zenith adjustment (the parallelity of the head front and capstan) that has any effect on the tape guidance (see fig. 3.1).

Check, and if necessary adjust zenith for the playback head, record head, erase head, and the tape rest 254844A (fig. 2.11). The zenith alignment is referred to the capstan. If the special tool for checking of the zenith alignment is not available, a ruler and a spacer can be used for a rough check as shown in fig. 2.10. The spacer must have an absolutely even thickness to obtain a good result. If may be necessary to remove the right hand tape guide post 991054 in order to give room for the ruler.

The zenith position of the heads can be adjusted with the head screws, while taking care to maintain a correct height and azimuth position. The tape rest can be bent with a flat-nosed plier if necessary. In order not to scratch the tape rest, protect it with a piece of tape during adjustment.

The bias head should be parallel to the front of the record head. If necessary, twist the arm holding the head to obtain the required parallelity. Ensure that the tape does not interfere with the spacer ribbon along the upper and lower edges of the bias head, and adjust if necessary by bending the arm (the head must not touch the height adjustment screw on the recording head).

Note that the above checks is only related to guiding of the tape. The final head adjustment (paragraph 3.0) includes height and azimuth alignment only and must be performed after alignment of the tape path in order to ensure that the zenith adjustment is not upset.

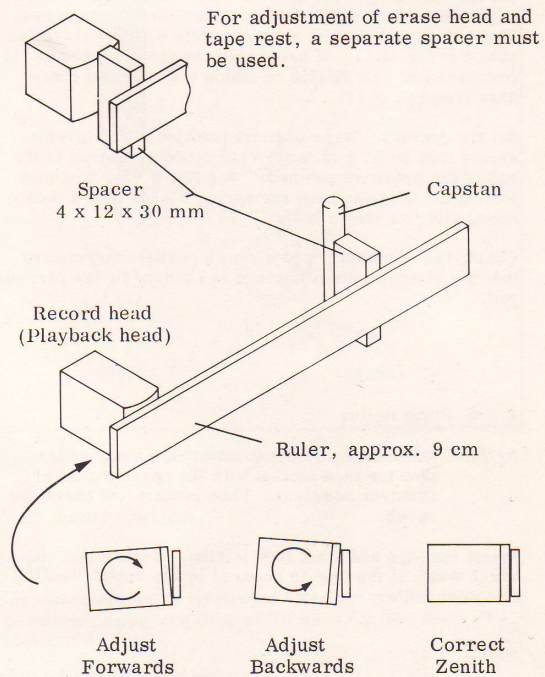

Fig. 2.10 Checking of head azimuth with ruler and spacer.

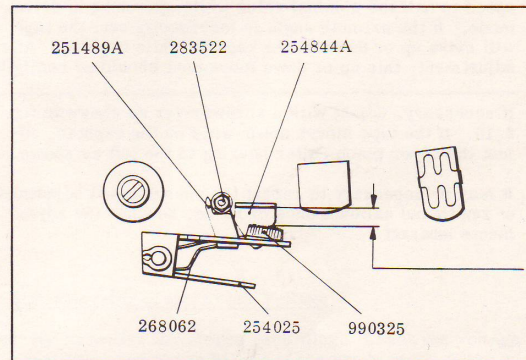

Fig. 2.11 Clearance between pressure pad and tape rest.



### 2.3.5 Pressure Pad

Set the operating lever in Neutral position. The clearance between the pressure pad 990325 and the tape rest 254844A should then be approximately 6.5 mm (1/4") as shown in fig. 2.11. If necessary, bend the tongue on the pressure pad arm 254025 to obtain the required clearance (see fig. 2.12).

Set the operating lever to Drive position. The tension should then be 80 g (2.8 oz)  $\pm 10\%$  when measured at the end of the pressure pad arm. See fig. 2.13. When adjusting the tension, bend the spring 268062 with a thin-nosed plier as shown in fig. 2.14.

Check the pressure pad's zenith position and ensure that the entire width of the tape is covered by the pressure pad.

### 2.3.6 Pinch Roller

**NOTE:** After each attempt to adjust the pinch roller stop the tape motion with the operating lever (Neutral position). Then restart and check the result.

Insert the tape and start tape motion. Ensure that the whole width of the tape is covered by the rubber coating on the pinch roller.

#### Zenith:

Incorrect zenith alignment will cause a slight flickering of the tape along upper or lower edge between capstan and the fixed right hand guide post. To adjust the pinch roller, loosen the fixing screw of the latch 236045 (fig. 2.15) and turn the latch until the tape runs without flickering. When flickering occurs along the upper edge of the tape, turn the latch clockwise. Tighten the fixing screw after adjustment.

#### Azimuth:

The azimuth position of the head can be checked by braking the supply turntable with the finger to reduce the tape speed to half the nominal value while operating in drive mode. If the azimuth angle is incorrectly set, the tape will move up or down on the capstan while braking. After adjustment, this up or down movement should be negligible.

If necessary, adjust with a screwdriver as shown in fig. 2.15. If the tape moves downwards on the capstan, adjust the upper pinch roller bearing to the left as shown.

It may be necessary to repeat the checking and adjustment of zenith and azimuth once or twice, because the adjustments interact.

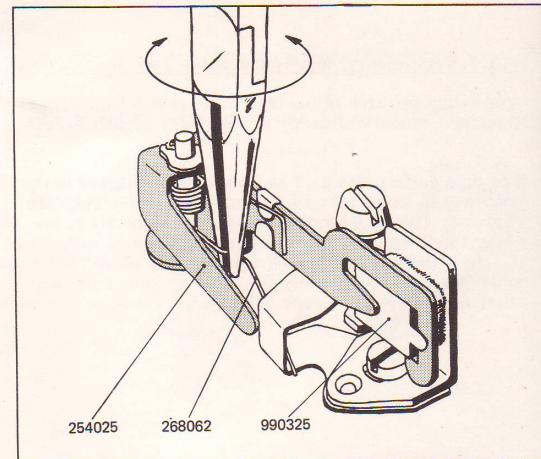

Fig. 2.12 Adjustment of clearance between pressure pad and tape rest.

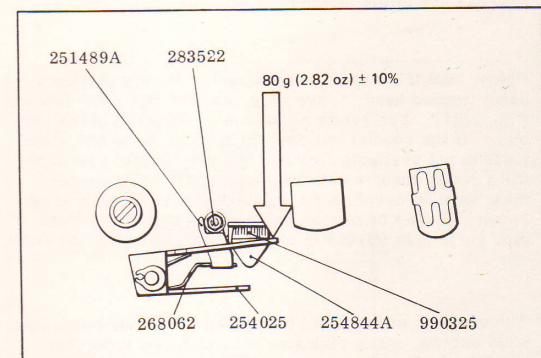

Fig. 2.13 Checking of pressure pad tension.

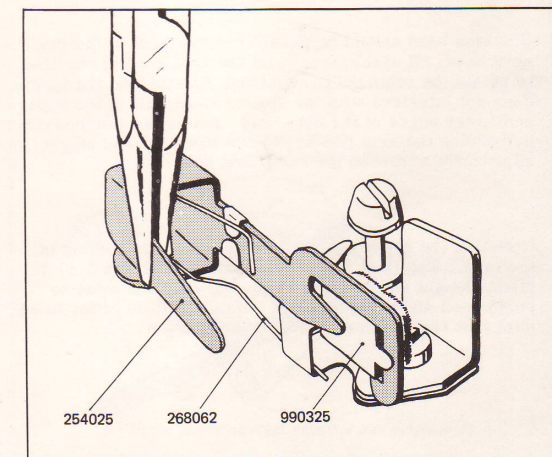

Fig. 2.14 Adjustment of pressure pad tension.



### 2.3.7 Inertia Idling Roller

**NOTE:** After each attempt to adjust the inertia idling roller, stop the tape motion with the operating lever (Neutral position). Then restart and check the adjustment.

Only the azimuth angle of the inertia idler should be adjusted. Set the tape recorder in Drive mode at 7 1/2 ips and adjust with a screwdriver as previously explained for the pinch roller, to obtain a very slight tilt of the idler ( $1^{\circ}$  -  $2^{\circ}$ ) towards the left. Proceed as follows:

Adjust the upper bearing to the left until it can be clearly seen that the tape hits the upper flange on the tape guide post nearest the inertia idling roller. Then move the bearing slightly towards the right until the tape barely hits the lower flange of the tape guide post. If the tongue is released in this position, it will move back enough to give the inertia idling roller the desired tilt towards the left. When properly adjusted, the tape will move away from the lower flange and barely touch the upper flange on the guide post to the left of the inertia idling roller when the tongue is released.

To facilitate checking, place a light source above and behind the tape recorder, and look from front against the lower flange on the guide post.

### 2.3.8 Checking and Readjustment of the Tape Guide Posts

By giving the inertia idling roller a slight inclination (paragraph 2.3.7), the roller will give the tape a light upward lift causing the tape to touch the upper flange on the tape guide posts 2, 3, and 4 (fig. 3.2). The result is a very precise guidance of the tape past the heads. For the best possible result, readjust tape guide posts 283522 so that each one touches the tape with the upper flange, taking care to avoid that the tape bulges at any of the guide posts. The guide posts are adjusted in the sequence 4, 3, 2 (fig. 3.2) while the tape is moving at 7 1/2 ips. Repeat the adjustment until the tape guidance is as smooth as possible. In the Drive mode it should hardly be possible to see that the tape is moving.

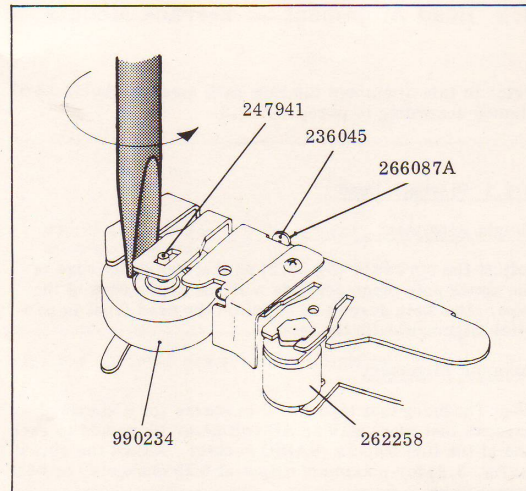

Fig. 2.15 Pressure wheel azimuth adjustment.

## 2.4 Lubrication

### Motor:

The motor should be lubricated after every 3000 hours of operation. Apply one drop of Teresso oil No. 43 or 47 from ESSO.

### Self-lubricating Bearings:

Turntables, flywheel and transfer wheel are mounted in self-lubricating bearings and should under normal conditions not need any attention. If for some reason lubrication appears to be necessary, use Teresso oil No. 43 or 47 from ESSO.

**NOTE:** Do not use more than one drop of oil in each bearing, as excessive oil may penetrate into the drive mechanism and disturb the friction conditions.

## 3.0 Electrical Checks and Adjustments

### 3.1 Erase- and Bias Circuits

#### 3.1.1 Oscillator Frequency

By means of a coil with about 10 turns placed around the erase head, couple a frequency meter or counter inductively to the oscillator circuit. Set the tape recorder for recording and if necessary change value of C502 to obtain a frequency reading of approx. 85.5 kHz. Tolerance: 80 - 100 kHz.

Alternatively, use a calibrated longwave receiver tuned to 256.5 kHz (3rd harmonic of oscillator frequency).

#### 3.1.2 Checking of the Erase Voltage

Set the recorder for stereo recording. Check the voltage across upper and lower halves of the erase head, using an

AC voltmeter, with a low capacitance test probe (max. 15 pF). The two voltages should be equal, in the range 80 to 120 V.

Check that each one of the voltages in mono recording does not depart more than 10 V from the voltages measured in stereo.



### 3.2 Head Alignment - 2-track Models

Prior to this alignment the tape path must be checked and aligned according to paragraph 2.3.

#### 3.2.1 Playback Head

##### Height Alignment

Adjust the screws A (fig. 3.2) so that the upper edge of the upper pole piece coincide with the upper edge of the tape. Use both screws to maintain the head front in parallel alignment with the tape.

##### Azimuth Alignment

Play Tandberg test tape No. 2 in stereo (or a standard azimuth test tape) with an AC voltmeter connected to each one of the line outputs (RADIO socket). Adjust the screw B (fig. 3.2) for maximum output of both channels, or best compromise.

##### Adjustment of Lateral Position

Checking and adjustment of the lateral position (fig. 3.1) is carried out for the playback head only and will normally not be necessary except when the head has been removed or other extensive repairs have been performed in the tape path. The recorders that can be adjusted, have a small disc (approximately 6 mm in diameter) placed between the rear height adjustment screw A (fig. 3.2) and the chassis.

With an AC voltmeter connected to the line outputs (RADIO socket pins 3 and 5), make a 3 3/4 ips recording of a 12 500 Hz signal in stereo at 0 dB indication on the record level meters. Depress both PLAYBACK buttons to obtain B-test monitoring.

Brake the supply turntable lightly. If the output voltage increases, check that the playback head is completely free of deposits or any kind of contamination. If necessary, clean the head and repeat the test. Then gently (with a match or any other non-metallic object) press the tape against the head front on each side of the gap of the playback head. If the lateral position is not correct, the output voltage will increase when the tape is pressed against the head on one side. In that case turn the head in the opposite direction until no increase of the output voltage can be observed when braking the tape.

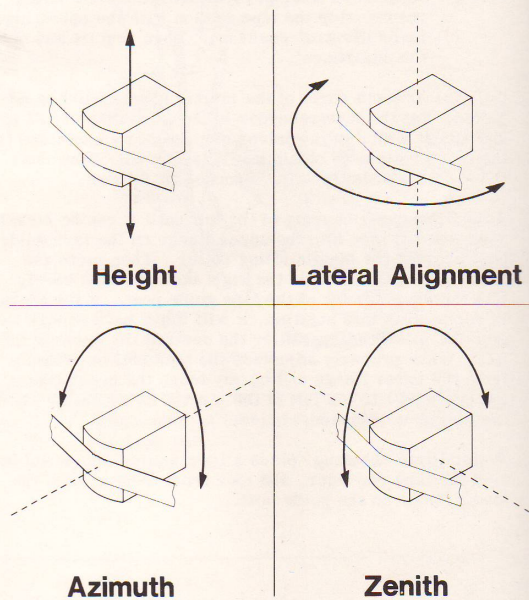

Fig. 3.1 Head adjustment.

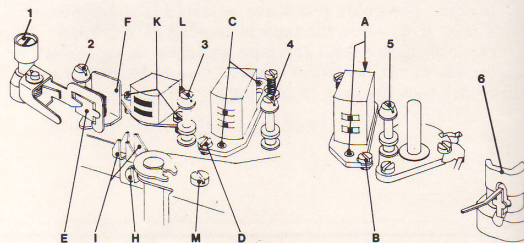

Fig. 3.2 Tape path adjustment screws.

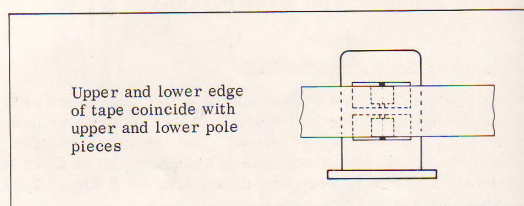

Fig. 3.3 2-track playback head. Height adjustment.



### 3.2.2 Record Head

#### Height Alignment

Adjust screws C (fig. 3.2) so that approximately 0.1 mm of the upper pole piece is visible above the tape. Use both screws to maintain the head front in parallel with the tape. To check the height position, record a 1000 Hz signal at a level well above normal on a new tape. Then dip the recorded length of the tape in "Magna-See" to make the tracks become visible. Correct height position corresponds to the tracks being symmetrically positioned across the width of the tape.

#### Azimuth Alignment

This adjustment requires that the bias head has been properly aligned. (See paragraph 3.2.3.)

Load a new tape. Make a 7 1/2 ips stereo recording of a 15 kHz signal with B-test (both RECORD and PLAYBACK buttons depressed). Connect an AC voltmeter to each one of the line outputs (RADIO socket) and set the INPUT LEVEL controls to obtain a reading of 75 mV. Adjust the screw D for maximum output of both channels, or best compromise.

### 3.2.3 Erase Head

#### Height Alignment

When the erase head is correctly aligned, approximately 0.25 mm of the ferrite cores should be visible above and below the tape. If necessary, adjust the screws K and L (fig. 3.2). Use both screws to maintain parallelity between headfront and tape. Check the height by running a prerecorded tape (Tandberg test tape No. 9) through in stereo recording with both INPUT LEVEL controls in minimum position. Dip the tape in "Magna-See" and check that the erased tracks are symmetrically positioned on the tape.

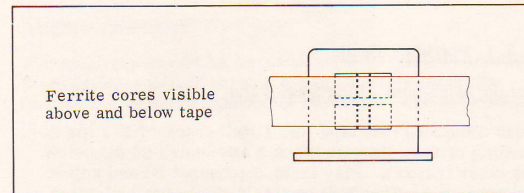

Fig. 3.4 2-track erase head. Height adjustment.

#### Azimuth Alignment

The head gaps should be perpendicular to the tape motion. If necessary, adjust with the screws K while maintaining the headfront parallel with the tape. This adjustment is not critical.

### 3.2.4 Alignment of Hum Shield for the Playback Head

The hum shield for the playback head is so positioned on the pressure roller arm that the shield is right in front of the head during playback.

Without tape in the tape path, set the recorder for stereo playback and put a piece of paper between the end-stop sensor and the guide post to start the motor. Set START/STOP knob to START. Connect an AC voltmeter to each one of the line outputs (RADIO socket). Loosen the screw holding the shield one quarter turn. Pull the shield as far away from the head as the mounting hole permits and adjust the shield sideways to obtain minimum reading on both voltmeters, or the best possible compromise. The hum voltage should not exceed 1 mV. After the adjustment, tighten the screw and seal with laquer.



### 3.3 Head Alignment - 4-track Models

Prior to this alignment the tape path must be checked and aligned according to paragraph 2.3.

#### 3.3.1 Playback Head

##### Height Alignment Using Test Tape

Load Tandberg test tape No. 1 (full-track, 7 1/2 ips recording of 1000 Hz with track 3 attenuated 36 dB below the other tracks). Play track 3 (channel R) and adjust the screws A, (fig. 3.2) to obtain minimum indication on an AC voltmeter connected to one of the line outputs (RADIO-socket). Use both screws to maintain the head front parallel with the tape.

##### Height Alignment Without the Use of Test Tape

Adjust the screws A (fig. 3.2) so that the upper edge of the upper pole piece lines up with the upper edge of the tape. See fig. 3.5. Turn both screws by equal amounts to maintain the head front parallel with the tape.

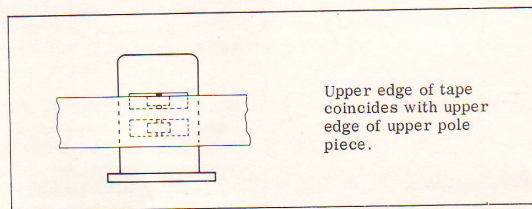

Fig. 3.5 4-track playback head. Coarse height adjustment.

When the record head has been aligned, the playback head can be checked as follows:

On a new tape record a 1000 Hz signal on track 1 (channel L) and a 500 Hz signal on track 3 (channel R), both at a level well above normal. Turn the tape around and play track 2 (channel R) in the opposite direction. When the head is in correct height position, no tone should be heard. If the 1000 Hz tone can be heard, the playback head is too low. If the 500 Hz tone is heard, the head is too high.

##### Azimuth Alignment

As explained for 2-track models. See paragraph 3.2.1.

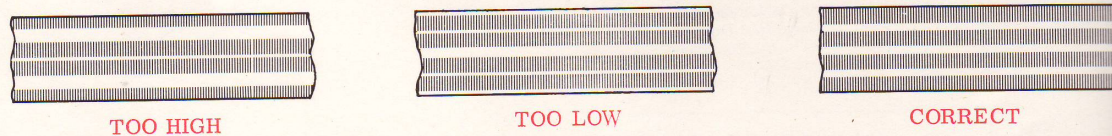

Fig. 3.7 Track measurement, 4-track record head.

##### Adjustment of Lateral Position

Checking and adjustment is performed as explained for 2-track models. See paragraph 3.2.1.

#### 3.3.2 Record Head

##### Height Alignment

Adjust the height adjustment screws C (fig. 3.2) so that approximately 0.1 mm of the pole piece is visible above the tape. See fig. 3.6. Turn both screws by equal amounts to maintain the head front parallel with the tape.

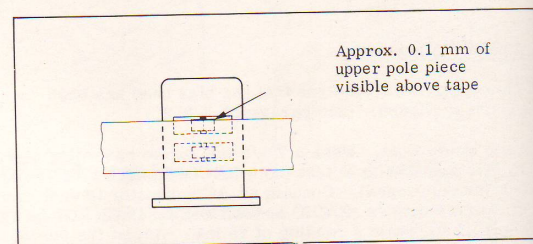

Fig. 3.6 4-track record head. Coarse height adjustment.

A test recording with subsequent track measurement should be carried out as follows:

Load a new tape. Record a signal in stereo at a level well above normal. After about 5 seconds, turn the tape around and record in the opposite direction on the same length of the tape. Cut off a length of the recorded tape and dip it in "Magna-See", to make the tracks become visible as four dark stripes with spacings in a lighter shade. The tracks should be evenly distributed across the width of the tape. See fig. 3.7.

##### Azimuth Alignment

As explained for 2-track models. See paragraph 3.2.2.



### 3.3.3 Erase Head

#### Height Alignment

Approximately 0.2 mm of the upper ferrite core should be visible above the tape. If not, adjust the screws K and L (fig. 3.2). Turn both screws by equal amounts to maintain the head front parallel with the tape. Then check the height position by track measurement.

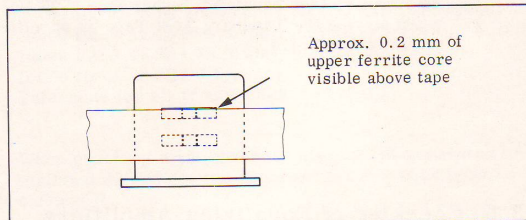

Fig. 3.8 4-track erase head. Coarse height adjustment

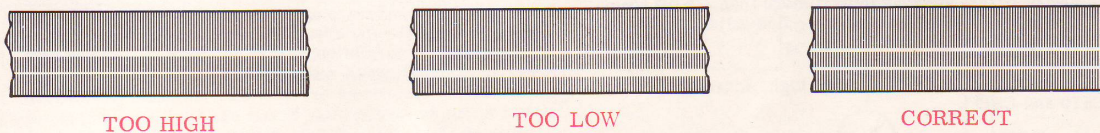

Fig. 3.9 Track measurement, 4-track erase head.

Load a Tandberg test tape No. 9 or another prerecorded full-track tape. Record 400 Hz for a few seconds on track 3 (channel R) at 7 1/2 ips. Dip the tape in "Magna-See" and check that the recorded track is centered in the erased track on the tape (fig. 3.9). If necessary, readjust, and make a new test recording with subsequent track measurements.

#### Azimuth Alignment

The head gap should be perpendicular to the tape motion. If necessary, adjust screws K (fig. 3.2), without disturbing the vertical position of the head. The alignment is not critical.

### 3.3.4 Alignment of Hum Shield for the Playback Head

As explained for 2-track models. See paragraph 3.2.5.

## 3.4 Adjustment of Amplifiers

### 3.4.1 Playback Level

Connect an AC voltmeter to each one of the line outputs (RADIO-socket). Play both channels from Tandberg Test Tape No. 4 at 7 1/2 ips. Adjust R 451 (left channel) and R 351 (right channel) to obtain a voltmeter reading of 0.75 V.

### 3.4.2 Bias

Load a Low Noise tape of good quality and connect an audio signal generator to both line inputs and an AC voltmeter to each one of the line outputs (RADIO socket). Tune the generator to 1000 Hz and set its output level at 0.5 V. Start the recorder in stereo recording at 7 1/2 ips with B-test (both RECORD and PLAYBACK buttons depressed). Set INPUT LEVEL to obtain a voltmeter reading of approximately 75 mV. Adjust C 510 (left channel) and C 511 (right channel) for maximum voltmeter indication.

False maximum reading may occur if the capacitor is too small.

To ensure an absolutely flat response in the treble range, check the overall record/playback curves and if necessary readjust the bias. See paragraph 3.4.3.

### 3.4.3 Adjustment of Record Level

Record a 400 Hz signal in stereo at 7 1/2 ips with A-test (both PLAYBACK buttons released) using new Low Noise Tape. Connect an AC voltmeter to each one of the line outputs and set INPUT LEVEL controls for 0.75 V reading on the voltmeters.

Depress both PLAYBACK buttons (B-test) and adjust R 117 (left channel), and R 217 (right channel) to obtain the same output voltage as in A-test (0.75 V).



### 3.4.4 Checking of the Frequency Response

If the bias has been optimally adjusted at 1000 Hz as described in paragraph 3.4.2, the response is flat over the specified frequency range. Component tolerances may, however, cause a departure from the ideal curve particularly in the treble range, and adjustment of the bias may be necessary. Check the frequency response as follows:

Connect an AC voltmeter to each one of the line outputs (RADIO-socket) via a low-pass or band-stop filter tuned to 85.5 kHz to prevent leakage of oscillator voltage from affecting the voltmeter reading. Connect an audio generator to the line inputs.

Load a Low Noise tape of good quality, and start the recorder for recording in 3 3/4 ips with B-test (both RECORD and PLAYBACK buttons depressed). Set the audio generator to 400 Hz and adjust INPUT LEVEL controls so that both voltmeters indicate 24 mV (30 dB below normal level which is 0.75 V). The output at 400 Hz is taken as the 0 dB reference level.

Alter the signal frequency to 12500 Hz while maintaining the same output from the generator and the same setting of the INPUT LEVEL controls. Check that the output voltage in B-test does not depart more than  $\pm 2$  dB from the reference level. If necessary, fine-adjust the azimuth position of the record head.

If the voltage at 12 500 Hz is too high, increase the bias (C510 and C511).

If the voltage at 12500 Hz is too low, repeat the adjustment explained for 7 1/2 ips in paragraph 3.4.2, but this time for 3 3/4 ips. This will result in a slight reduction of the bias and give a higher output at treble frequencies. If the output voltage is still too low at 12500 Hz, the equalizing amplifiers must be checked separately (see paragraphs 3.5.1 - 3.5.3). A further reduction of the bias is not recommendable, as it would have an unfavourable effect on the signal/noise ratio.

After adjustment of the bias, the record level must be readjusted (paragraph 3.4.3)

Check at other frequencies between 50 and 12500 Hz that the output level does not depart more than  $\pm 2$  dB from the reference level.

Finally check the frequency curves for 1 7/8 ips between 50 and 6000 Hz and for 7 1/2 ips between 40 and 18000 Hz.

### 3.4.5 Adjustment of Record Level Indicators

Connect an audio generator set for 0.5 V output at 400 Hz to the line inputs and an AC voltmeter to each one of the line outputs. Record in stereo with B-test, using Low Noise Tape of good quality and with the INPUT LEVEL controls set to give a voltmeter reading of 0.75 V for both channels.

Adjust R 433 (left channel) and R 333 (right channel) for 0 dB indication on the record level meters. Release the PLAYBACK buttons (A-test) and check that the output voltage is still 0.75 V for both channels.

After adjustment of the record level indicators, check the total distortion from tape and amplifiers as follows:

In addition to the equipment already in use (above), connect a distortion meter to each one of the line outputs (RADIO socket). Make a 7 1/2 ips stereo recording of a 400 Hz signal at 0 dB record level. If the distortion at the output (B-test) exceeds 3 %, the record level must be decreased as required and the record level meters re-adjusted to 0 dB for the new level.

To obtain correct output voltage (0.75 V) in playback from a tape recorded at 0 dB level, the playback level must also be readjusted. Record a 400 Hz signal at 0 dB in stereo with A-test. If the preceding adjustments have been correctly performed, the AC voltmeters connected to the line outputs will indicate 0.75 V. Depress the PLAYBACK buttons (B-test) and adjust R 451 (left channel) and R 351 (right channel) for 0.75 V at both line outputs.

NOTE: This correction of the playback level results in an output voltage somewhat higher than 0.75 V when playing the Tandberg Test Tape as specified in paragraph 3.4.1.

## 3.5 Checking of Equalizing Amplifiers

If the overall record/playback curves are not within tolerances even after the adjustments described in the preceding paragraph, it will be necessary to check the record and playback equalization amplifiers separately.

### 3.5.1 Checking of Playback Amplifiers Using Test Tape

Play Tandberg Test Tape No. 3 which is a full-track 7 1/2 ips recording of 250-10000-5000-1000-100-50-250 Hz. The tape is recorded in accordance with N.A.B. standard. Taking the level at 250 Hz as reference level (0 dB), the tolerances at the various frequencies are: 10 kHz: +4 dB, 5 kHz: -1 dB, +3 dB, all other frequencies:  $\pm 2$  dB.

### 3.5.2 Checking the Playback Equalizing Curves

Connect a 10 ohm resistor in series with playback head, and an audio signal generator to head via a series connection of 1 kohm and 320  $\mu$ F (fig. 3.10). Connect an AC voltmeter to one of the line outputs and set the recorder for playback from channel L. To avoid clipping of the signal, connect an oscilloscope in parallel with the AC voltmeter so that the output waveform can be observed.

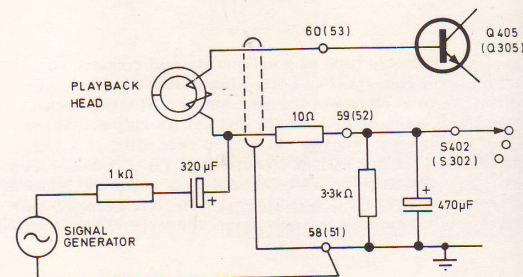

Fig. 3.10 Connections for checking of playback curves.



Tune the signal generator to 400 Hz and set its output voltage to give about 75 mV on the voltmeter connected to the line output (will correspond to 7-10 mV from the signal generator). Use this output as a reference and check that the playback amplifier gain varies according to the frequencies listed below:

50 Hz: + 13 dB. All tape speeds.  
 100 Hz: + 11 dB. All tape speeds.  
 400 Hz: 0 dB (reference level). All tape speeds.  
 5000 Hz: - 15 dB (7 1/2 ips), - 12 dB (3 3/4 ips), - 7 dB (1 7/8 ips).  
 10000 Hz: - 16 dB (7 1/2 ips), - 11 dB (3 3/4 ips).  
 15000 Hz: - 15 dB (7 1/2 ips).  
 Tolerance for all frequencies:  $\pm 1.5$  dB.

50 Hz: + 2 dB. All tape speeds.  
 100 Hz: + 1 dB. All tape speeds.  
 400 Hz: 0 dB (reference level). All tape speeds.  
 5000 Hz: + 4 dB (7 1/2 ips), + 6 dB (3 3/4 ips), + 12 dB (1 7/8 ips).  
 10000 Hz: + 7 dB (7 1/2 ips), + 11 dB (3 3/4 ips).  
 15000 Hz: + 8 dB (7 1/2 ips).

Tolerance for all frequencies:  $\pm 1.5$  dB.

Do not forget to remove the 100 ohm resistors in series with the record head winding and resolder resistor R 502 into circuitry when the measurements have been completed.

When checking right channel, connect the generator to terminal 52 and set the recorder for playback from channel R.

### 3.5.3 Checking the Record Equalizing Curves

To enable measurement of the record head current, insert a 100 ohm resistor between the head winding and ground as shown in fig. 3.11, and connect an AC voltmeter across the resistor. To stop the oscillator, solder resistor R 502 free from the board and connect an audio signal generator to the line inputs. Set the output of the signal generator at approximately 0.5 V.

Set the recorder for recording on one or both channels, and adjust the level to approximately minus 30 dB (- 10 dB by means of the input level controls and then a 20 dB step down on the generator).

Using the output at 400 Hz as a 0 dB reference, check that the record amplifier gain varies with the frequencies listed below.

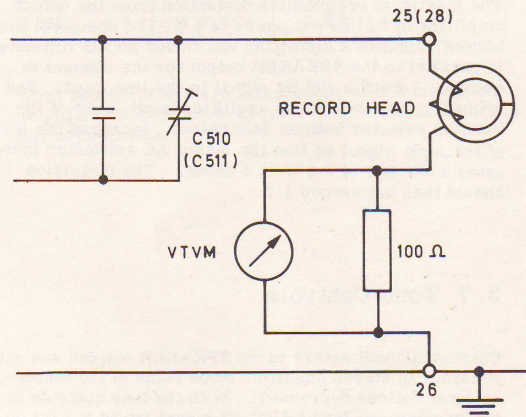

Fig. 3.11 Connections for checking record curves.

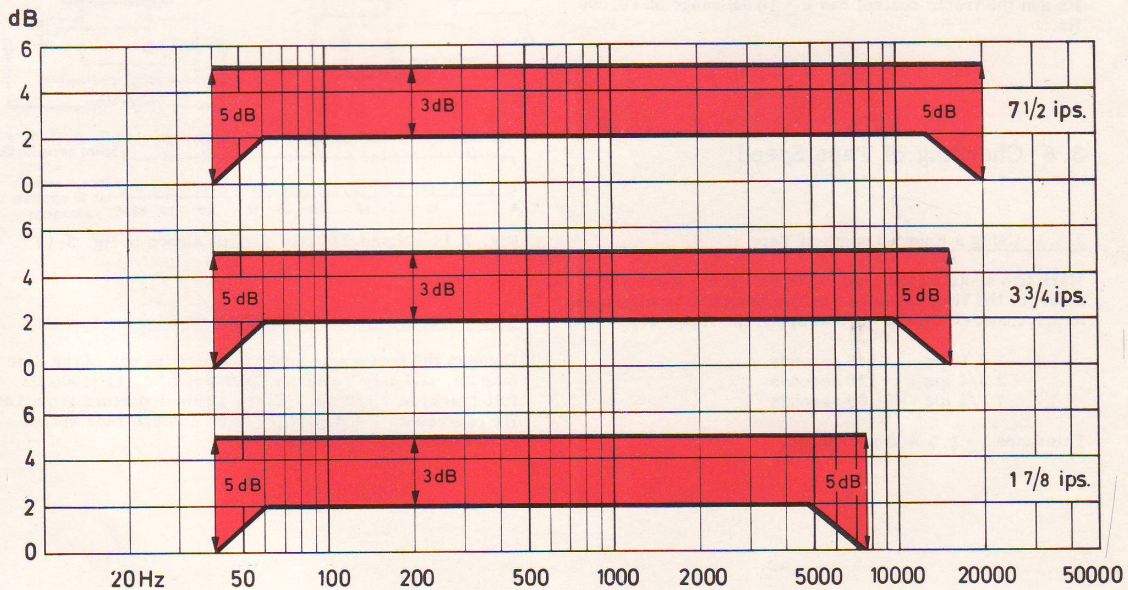

Fig. 3.12 Total frequency response tolerance according to DIN 45511.



### 3.6 Output Amplifiers

#### 3.6.1 Quiescent Current

Observe that the power has been on for a while before measuring the quiescent current. Set VOLUME controls to zero.

Connect a voltmeter across resistors R 139 and R 140 channel L, (R 239 and R 240 channel R), and adjust with the potentiometer R 134 (R 234 channel R) until the meter reads 30 - 100 mV.

#### 3.6.2 Checking of Distortion

The maximum permissible distortion from the output amplifier at full output power is 1%. To check the distortion, connect a distortion meter and an AC voltmeter in parallel to the SPEAKER output for the channel in question. Feed a 400 Hz signal to the line input. The recorder must be set for amplifier mode (none of the function selector buttons depressed). Increase the level of the input signal so that the output AC voltmeter indicates 4 - 4.5 V (4 - 6 W in 4 ohms). The distortion should then not exceed 1%.

### 3.7 Tone Controls

Connect AC voltmeters to the SPEAKER outputs and set the recorder in stereo amplifier mode (none of the function selector buttons depressed). With the tone controls in centre position, feed a 1000 Hz signal (about 0.5 V) into the line inputs and set INPUT LEVEL and VOLUME to obtain an output level of approximately 200 mV. Taking this output as a 0 dB reference, alter the frequency to check that the bass control has a  $\pm 10$  dB range at 50 Hz and the treble control has a  $\pm 10$  dB range at 10,000 Hz.

### 3.8 Checking of Tape Speed

#### 3.8.1 Using a Known Length of Tape

Mark two spots on the tape, 1144 cm (45'0") apart and measure the time taken to run this length of tape through in drive mode. At the normal speed the times are:

1 7/8 ips	240 seconds
3 3/4 ips	120 seconds
7 1/2 ips	60 seconds

Tolerance:  $\pm 1.5\%$  at all speeds.

#### 3.8.2 Using Transformer and AC Voltmeter

Connect an AC voltmeter and the secondary winding of a mains transformer (0.5 - 6 V 50/60 Hz) to one of the SPEAKER outputs as shown in fig. 3.16. Play Tandberg Test Tape 10a if the line frequency is 50 Hz (or 19a if the line frequency is 60 Hz) at 7 1/2 ips. Adjust VOLUME to obtain an output voltage approximately equal to the transformer secondary voltage. Any departure from correct speed will cause the voltmeter needle to pendle at the beat frequency. Measure the time for 10 complete excursions of the meter needle and read the deviation from nominal tape speed in the nomogram, fig. 3.17.

To determine whether the speed is too high or too low, brake the supply turntable lightly. If the beat frequency then increases (faster pendling), the speed is too low.

For checking of the tape speed at 3 3/4 ips, use Tandberg Test Tape 10b (line frequency 50 Hz) or 19b (line frequency 60 Hz).

Speed tolerance: 1.5% for all tape speeds.

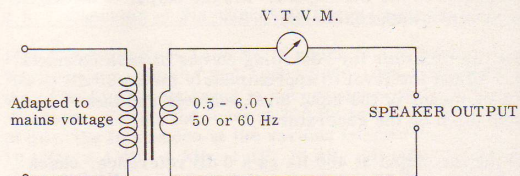

Fig. 3.13 Connections for speed control using transformer and AC voltmeter.

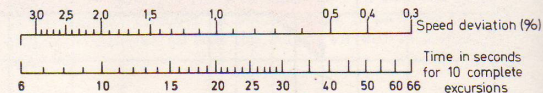

Fig. 3.14 Nomogram for circuit shown in fig. 3.13.

#### 3.8.3 Using Frequency Meter or Counter

Connect the frequency meter (counter) to one of the line outputs, and play Tandberg Test Tape No. 11 (1000 Hz full-track) at 7 1/2 ips. Every 10 Hz departure from 1000 Hz represents 1% departure from nominal tape speed. Speed tolerance:  $\pm 1.5\%$ .



## 4.0 Modifications

### 4.1 Modifications for a Different Line Voltage and Frequency

A label on the power transformer shows how to wire transformer and motor for 115/130/230/240 V, 50 Hz. Another label on the motor shows the rewiring for 115/230 V, 60 Hz.

When converting to operation on a different frequency, the motor pulley must be replaced. Please specify part number when ordering motor pulley:

Motor pulley for 50 Hz: Part No. 301826  
 Motor pulley for 60 Hz: Part No. 248351B

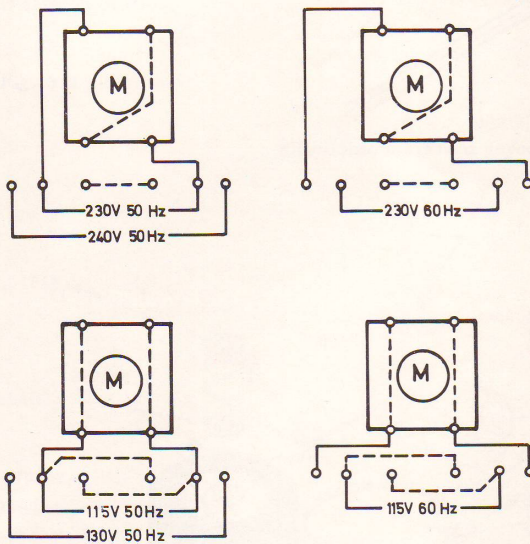

Fig. 4.1 Rewiring for motor and mains transformer.

### 4.2 Modification 2-Track/4-Track

The following components differ in the 2-track and 4-track models:

Part	4-track	2-track	Notes
Record head	11R - F53	07R - F82	Fig. 5.6
Playback head	10P - C03	11P - F83	Fig. 5.6
Erase head	13E - C44	20E - D87	Fig. 5.6
R 432	3.3 K	2.7 K	
R 332	3.3 K	2.7 K	

When modifications are introduced, adjust heads and amplifiers according to chapter 3.0, electrical checks and adjustments.



## 5.0 Illustrations with Part Numbers

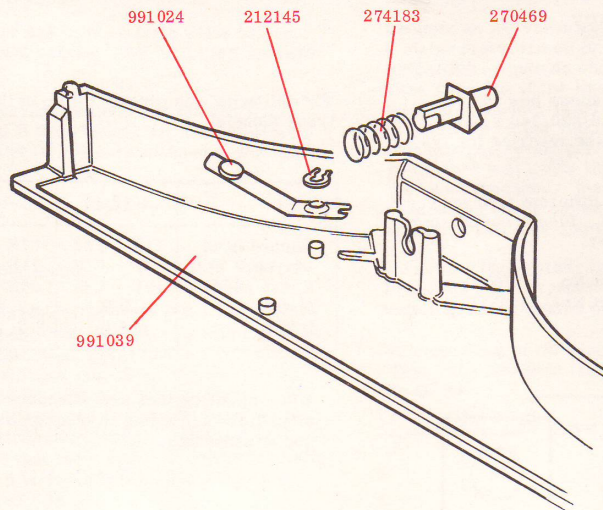

Head cover seen from underneath.

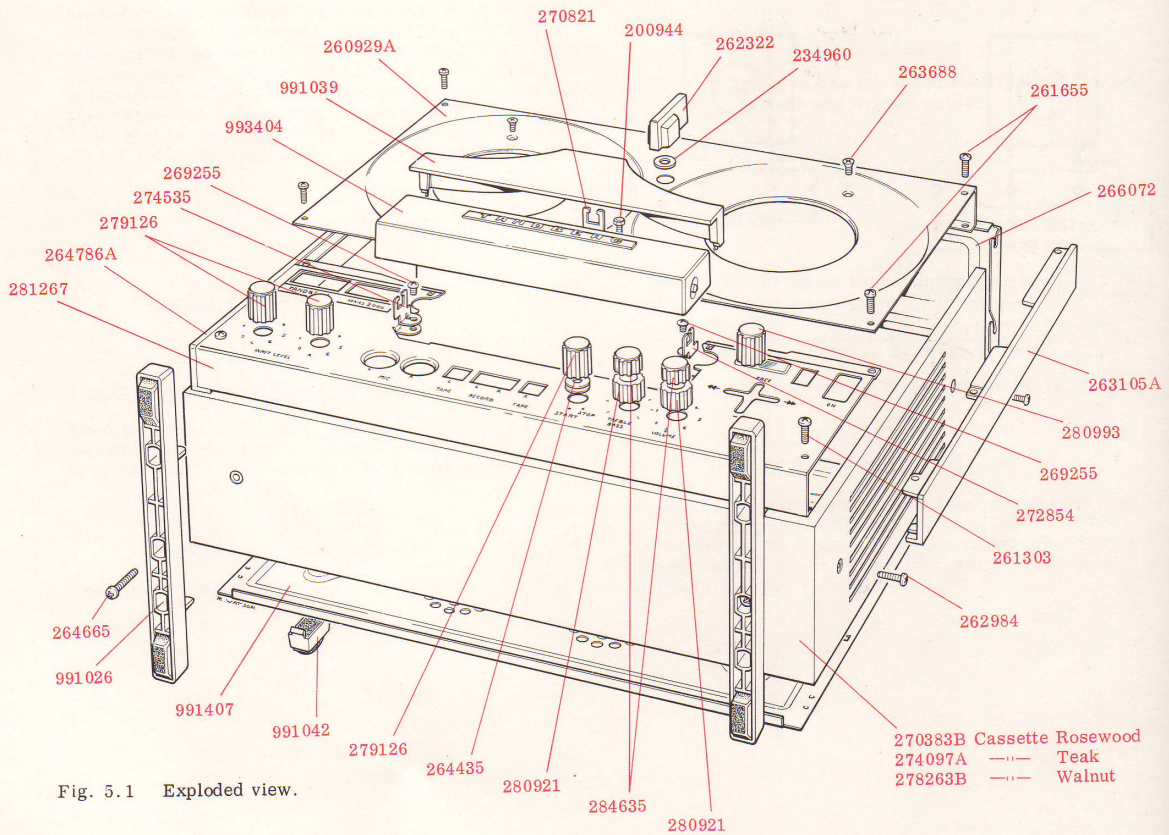

Fig. 5.1 Exploded view.



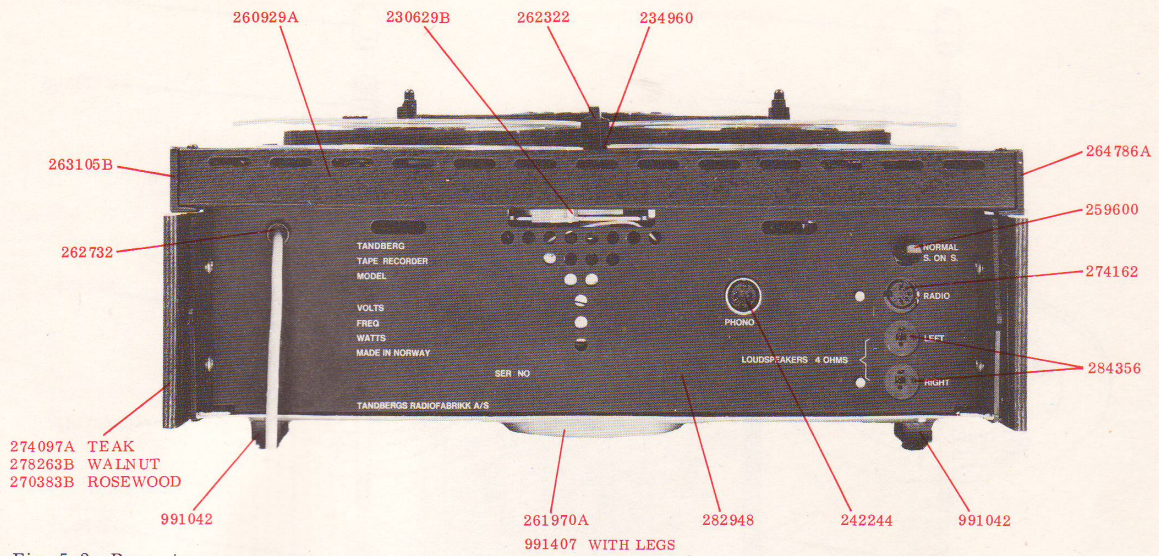

Fig. 5.2 Rear view

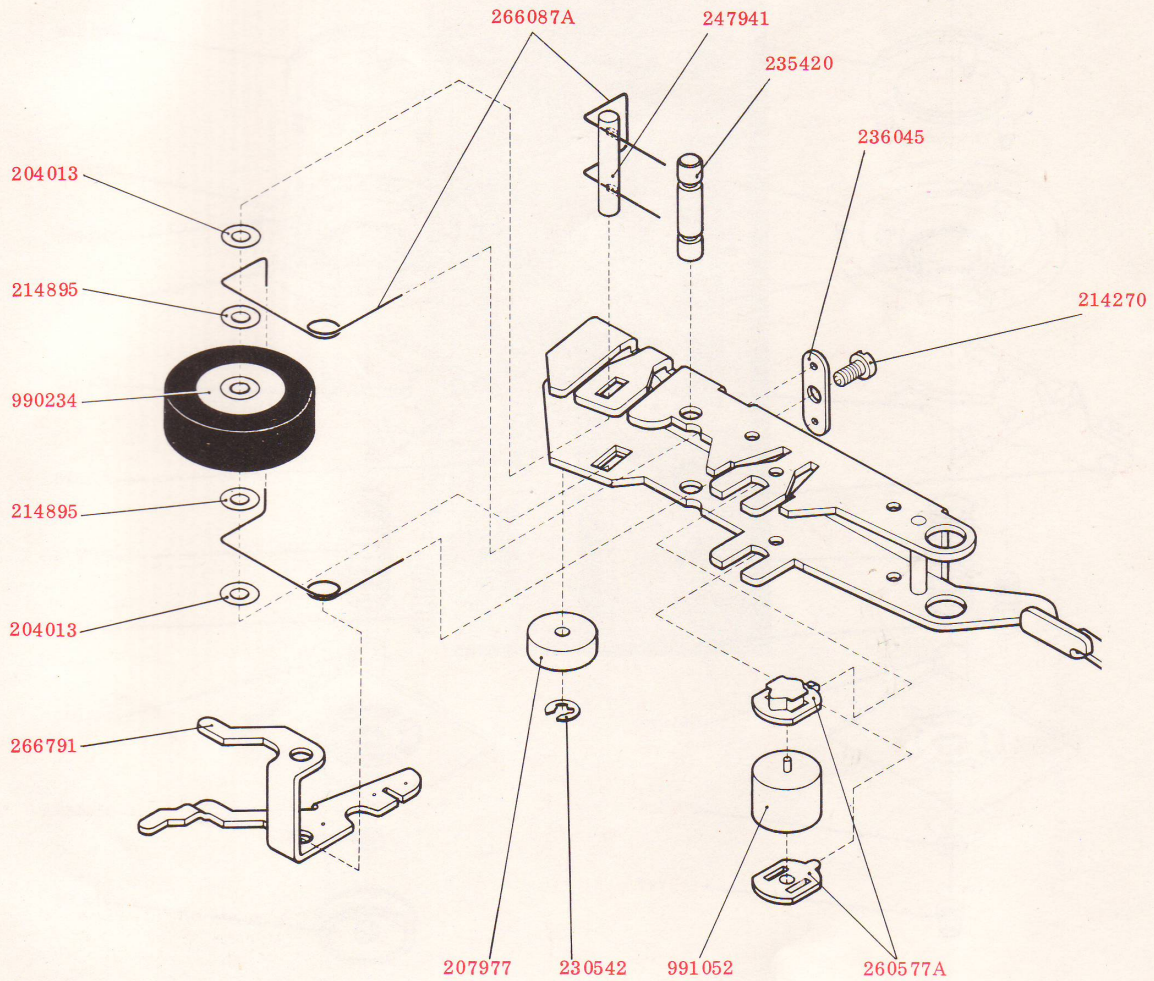

Fig. 5.3 Pressure roller arm.



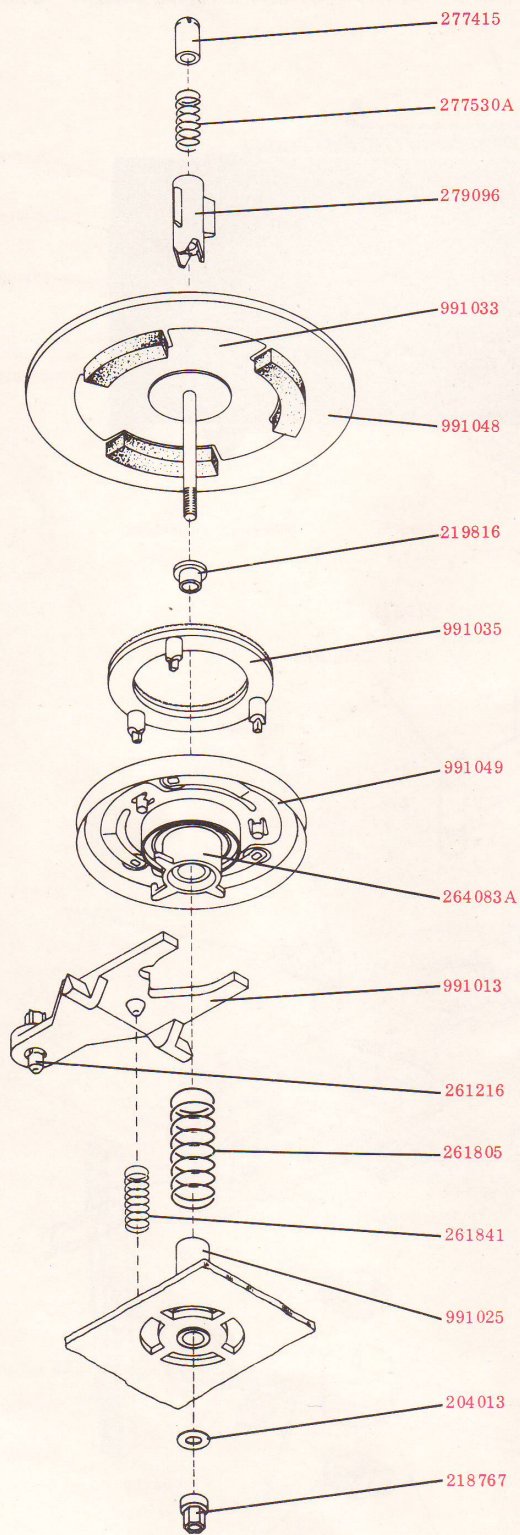

Fig. 5.4 Left turntable.

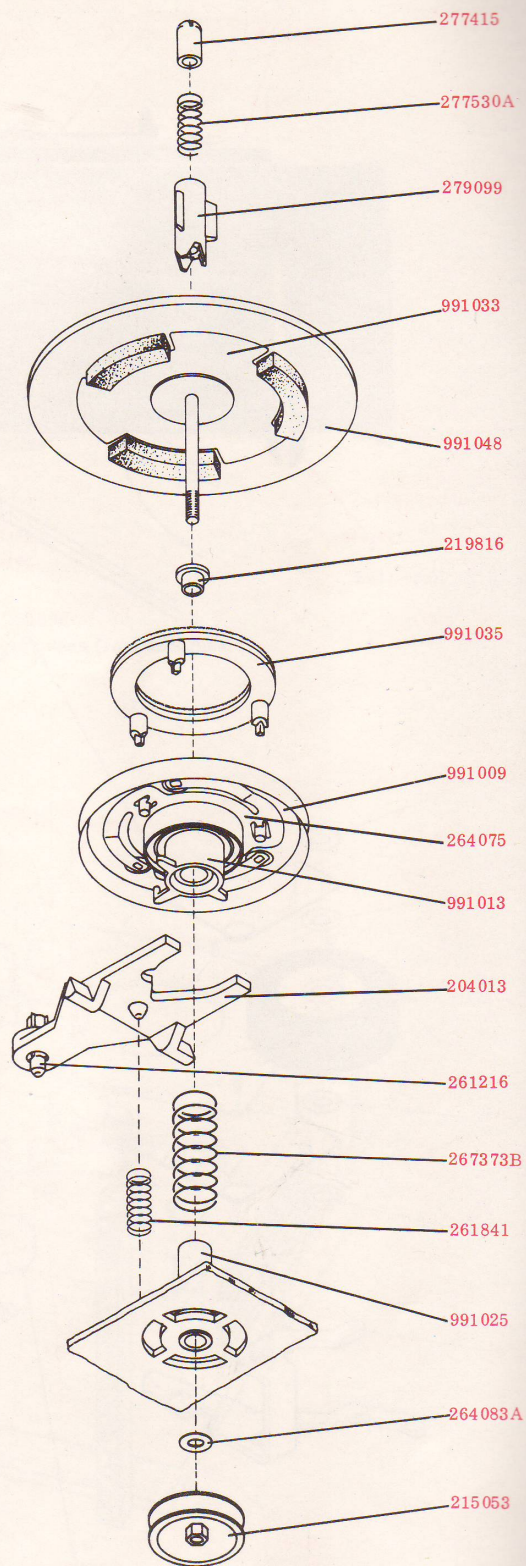

Fig. 5.5 Right turntable.



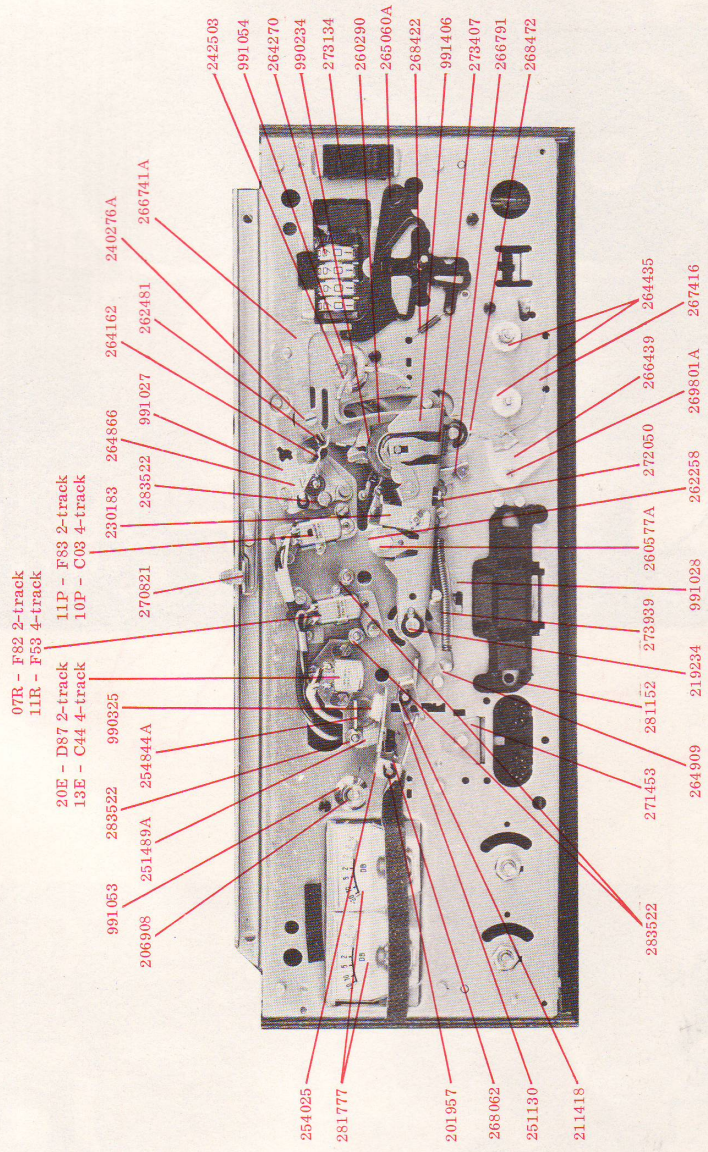

Fig. 5.6 Front top view with covers removed.



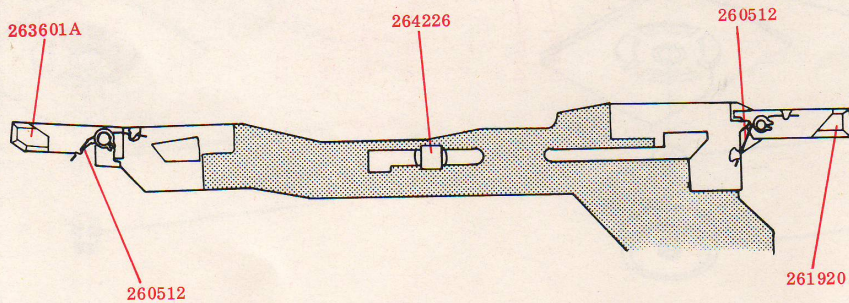
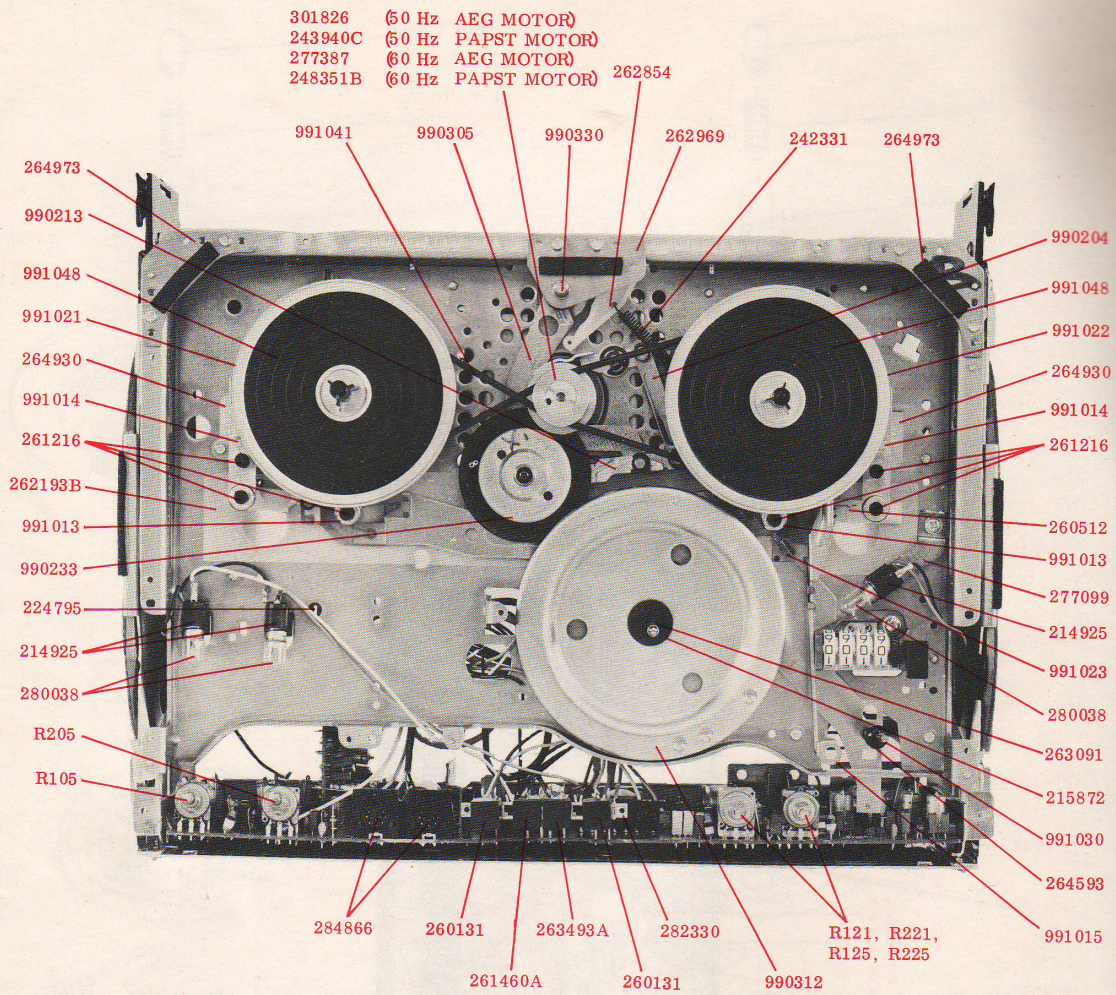

Fig. 5.7 Top view with upper mounting plate removed.



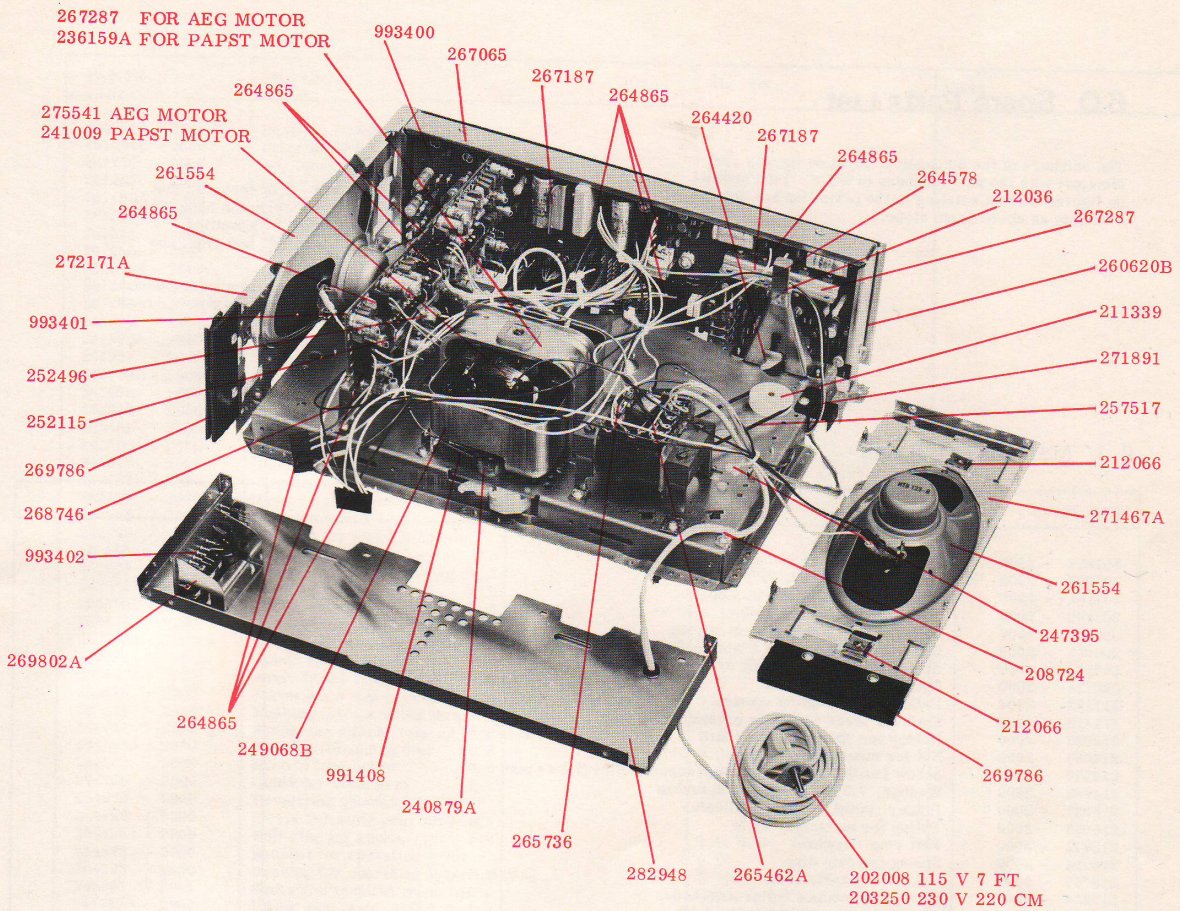

Fig. 5.8 Bottom view.

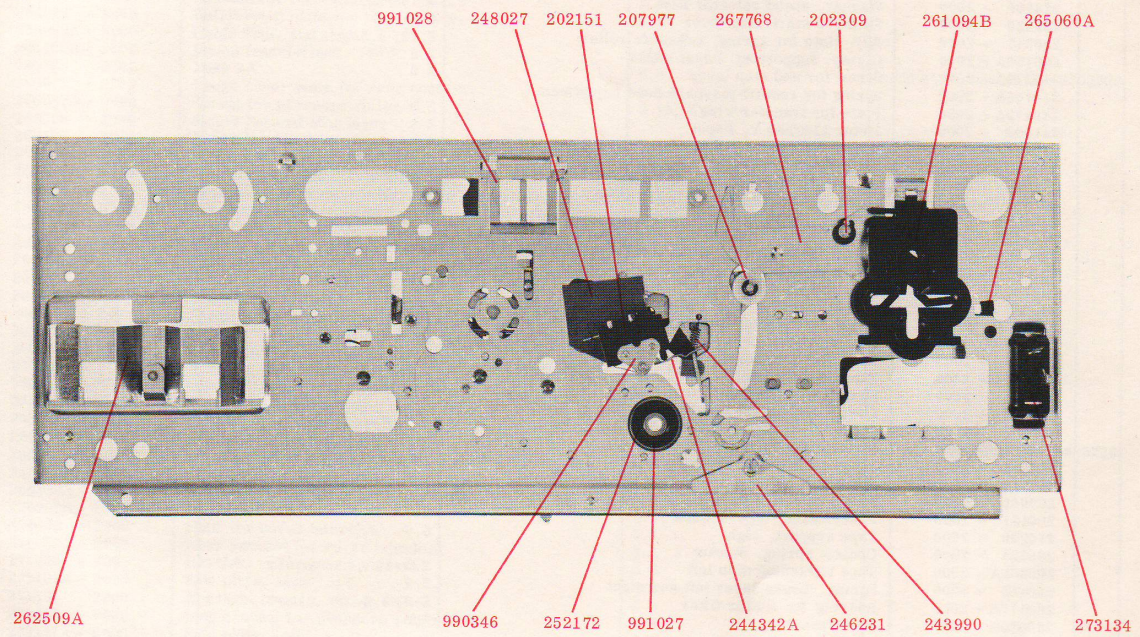

Fig. 5.9 Upper mounting plate.



## 6.0 Spare Parts List

The numbers of the mechanical parts on figures are identical with the part numbers in store. Part shown on figures without existing in the parts list are not available as spare parts alone.

### Ordering of Parts

When ordering a mechanical part, it is essential that the appropriate part number and description being used as a reference in this manual, must be specified. For ordering of electrical components, however, the position number must be used.

Note: If modifications according to list are introduced from a certain serial number, this number must be specified.

### 6.1 Mechanical Parts

Part No.	Description	Fig. ref.	Notes
201957 - 2000	Shaft for pressure pad arm	5.6	
202008 - 2000	Mains cable, 115 V, 7FT	5.8	
202151 - 2000	Microswitch RX1 for end stop	5.9	
202309 - 2000	Shaft for eccentric segment	5.9	
203250 - 2000	Mains cable, 230 V 220 cm w/plug	5.8	
204013 - 2000	Washer, 7.5 x 4.2 x 0.5 mm turbax	5.3, 5.4, 5.5	
207977 - 2000	Acetal roller for indexing eccent. segment	5.3, 5.9	
208724 - 2000	Clamp for mains cable	5.8	
211339 - 2000	Pulley for revolution counter	5.8	
211418 - 2000	Shaft for lever operating pressure pad arm	5.6	
212036 - 2000	Holder for operating lever ball	5.8	
212066 - 2000	Nut for mounting of cabinet	5.8	
214270 - 2000	Screw for adj. plate, spring pressure roller (2.6 x 4 mm)	5.3	
214895 - 2000	Washer, 7.5 x 4.2 x 0.3 mm turbax	5.3	
214925 - 2000	Holder, lamp, counter/indicator		
215053 - 2000	Pulley for turntable, right	5.5, 5.7	
215872 - 2000	Felt ring, flywheel	5.7	
216734 - 2000	Spring for cam disc		
218767 - 2000	Nut for turntable shaft, left	5.4	
219234 - 2000	Shaft for pressure roller arm assy.	5.6	
219816 - 2000	Flange for turntable housing L&R	5.4, 5.5	
224795 - 2000	Support for PW board	5.7	
230183 - 2000	Shield for playback head	5.2, 5.6	
230542 - 2000	Circlip, 2.3 mm	5.3	
230629B - 2000	Roller for speed selector arm	5.8	
234960 - 2000	Washer, speed selector knob.	5.1, 5.2	
235420 - 2000	Shaft for start/stop lever	5.3	
236045 - 2000	Adj. plate for spring, pressure roller	2.15, 5.3	
236159A - 2000	Clamp, supporting Papst motor	5.8	
240276A - 2000	Screw for end stop lever	5.6	
240406A - 2000	Spring for record-playback head adjustment		
240879A - 2000	Plate for transfer wire	5.8	
241009 - 2000	Motor 115/230 V, Papst	5.8	
242244 - 2000	Socket for record player, DIN	5.2	
242331 - 2000	Spring for cam disc arm	5.7	
242503 - 2000	Tape feeler for end stop mechanism	2.7, 5.6	
243940C - 2000	Motor pulley for Papst motor, 50 Hz	5.7	
243990 - 2000	Spring for tape feeler, end stop mechanism	2.7, 5.9	
244342A - 2000	Lever for end stop switch	5.9	
246231 - 2000	Clamp for end stop switch wires	5.9	
247395 - 2000	Clip 9 mm (3/8") for wires	5.8	
247941 - 2000	Shaft for pressure roller	2.15, 5.3	
248027 - 2000	Insulator for end stop switch	5.9	
248351B - 2000	Motor pulley for Papst motor, 60 Hz	5.7	
249068B - 2000	Box for motor	5.8	
251130 - 2000	Lever for pressure pad arm	5.6	
251489A - 2000	Tape support left	2.11, 2.13, 5.6	
252115 - 2000	Equalization switch	5.9	
252172 - 2000	Lower bearing for flywheel	5.9	
252496 - 2000	Clamp, link, equal. switch	5.9	
254025 - 2000	Pressure pad arm	2.11, 2.12, 2.13, 2.14, 5.6	
254844A - 2000	Support for pressure pad & tape	2.11, 2.13, 5.6	
257517 - 2000	Drive belt for counter	5.8	
259600 - 2000	Sound-on-Sound switch	5.2	
260131 - 2000	Push-button, tape/source	5.7	
260290 - 2000	Tape support, right	5.6	
260325 - 2000	Contact spring, Stocko		
260361A - 2000	Tape tightening disc left	2.5	
260512 - 2000	Spring, brake lever left and right	5.7	
260577A - 2000	Bearing for flutter filter	5.3, 5.6	
260620B - 2000	Front panel	5.8	



Part No.	Description	Fig. ref.	Notes
260929A - 2000	Rear top cover plate	5.1, 5.2	
261094B - 2000	Index guide for operating lever	5.9	
261216 - 2000	Adj. screw for clutch- and brake levers	2.6, 5.4, 5.5, 5.7	
261303 - 2000	Screw, 3 x 10 mm for front cover plate	5.1	
261460A - 2000	Button for recording left channel	5.7	
261525 - 2000	Stud for lifting arm	5.8	
261554 - 2000	Loudspeaker HT 123 - 8 ohms	5.1	
261655 - 2000	Screw, japanned, 3 x 10 mm for rear top cover plate	5.4	
261805A - 2000	Coil spring for left clutch disc	2.3, 5.4, 5.5	
261841 - 2000	Coil spring for clutch- and brake levers	5.7	
261885 - 2000	Screw for feeler arm, end stop	5.2	
261920 - 2000	Arm, brake right, acetal	5.7	
261970A - 2000	Bottom cover	5.2	
261992 - 2000	Thrust disc for flywheel bearing	5.7	
262193B - 2000	Mylar slide plate	2.15, 5.3, 5.6	
262258 - 2000	Flutter filter roller	5.1, 5.2	
262322 - 2000	Knob for speed selector	5.6	
262481 - 2000	Tape braking arm, start/stop	5.9	
262509A - 2000	Shield for indicator	5.2	
262545 - 2000	Holder for speed selector arm spring	5.7	
262732 - 2000	Grommet for mains cable	5.7	
262739 - 2000	Lower spring for operating lever	5.7	
262854 - 2000	Speed selector arm	5.7	
262969 - 2000	Bracket for speed selector	5.1	
262984 - 2000	Screw 5/8" for cabinet	5.7	
263077 - 2000	Spring for tape tightening disc	5.1	
263091 - 2000	Housing, flywheel	5.7	
263105B - 2000	Upper side plate, right	5.1, 5.2	
263443 - 2000	Bracket for flywheel bearing	5.7	
263493A - 2000	Button for recording right channel	5.7	
263522A - 2000	Upper spring for operating lever	5.7	
263601A - 2000	Arm, brake left, acetal	5.1	
263688 - 2000	Screw 3 x 8 mm c.sunk for rear top cover plate	5.5	
263874 - 2000	Bushing for operating lever	2.3, 2.4, 5.4, 5.5	
264075 - 2000	Spring for clutch, take up turntable	5.6	
264083A - 2000	Bushing for clutch disc	5.7	
264162 - 2000	Rubber tape brake	5.6	
264226 - 2000	Guide for slide arm	5.7	
264270 - 2000	Revolution counter	5.6	
264420 - 2000	Sleeve for slide arm damping	5.1, 5.6	
264435 - 2000	Felt ring for knobs	5.8	
264578 - 2000	Bracket for operating lever	5.7	
264593 - 2000	Bushing for operating lever indexing	5.1	
264665 - 2000	Screw for vertical mounting	5.1, 5.2	
264786A - 2000	Upper side plate, left	5.8	
264830 - 2000	Rubber foot for vertical mount. leg	5.6, 5.7	
264865 - 2000	Terminal plug 7 pins, main ampl. board	5.6	
264866 - 2000	Spring for tape brake arm	2.6, 5.7	
264909 - 2000	Post for pressure roller arm spring	5.6	
264930 - 2000	Bracket for turntable brake levers	5.6	
264973 - 2000	Reinforcing plate for rear corners	5.6, 5.9	
265060A - 2000	Guide arm, end stop	5.8	
265462A - 2000	Mains transformer, 720 Y	5.8	
265736 - 2000	Fuse 2A	5.1	Valid above serial No. 2363236
266072 - 2000	Loose cover plate for rear connect.	2.15, 5.3	
266087A - 2000	Spring for pressure roller	5.6	
266309 - 2000	Sleeve for end stop lever	5.6	
266439 - 2000	Lever for instantaneous start/stop mechanism	2.7, 5.6	
266733 - 2000	Nut 3 mm, tape guide	5.6	
266741A - 2000	Arm for end stop mechanism	5.8	
266791 - 2000	Fork for instantaneous start-stop mechanism	5.8	
267065 - 2000	Bracket, main amplifier board	5.8	
267187 - 2000	Heath sink, brass.	5.8	
267287 - 2000	Clamp, supporting AEG motor	5.8	
267373B - 2000	Coil spring for left and right clutch disc	2.3, 2.5, 5.4, 5.5	
267416 - 2000	Spring for inst. start/stop arm.	5.6	
267768 - 2000	Eccentric segment	5.9	
268062 - 2000	Spring for pressure pad arm	2.11, 2.12, 2.13, 2.14, 5.6	
268120 - 2000	Bracket for instantaneous start/stop	5.6	
268422 - 2000	Spring for end stop guide arm	5.6	
268472 - 2000	Arm for instantaneous start/stop	5.8	
268746 - 2000	Support, equalizing amplifier board	5.1	
269097 - 2000	Strap for transfer wire	5.8	
269255 - 2000	Screw for cover bracket 3 x 4 mm	5.1	
269450 - 2000	Fuse, 1.25 A slow	5.8	Valid below serial No. 2363236
269786 - 2000	Bracket for fastening rear cover plate	5.6	
269801A - 2000	Shaft for inst. start/stop lever	5.8	
269802A - 2000	Bracket, mounting connector board	5.1, 5.2	
270383B - 2000	Rosewood cabinet	5.1	
270469 - 2000	Shaft for cover interlock	5.1, 5.6	
270821 - 2000	Rear bracket for cover interlock	5.6	
271453 - 2000	Bracket, microphone contact	5.8	
271467A - 2000	Side plate, right	5.8	
271891 - 2000	Bracket, plastic, mains switch	5.8	
272050 - 2000	Stop bracket for pressure roller arm	5.6	
272171A - 2000	Side plate, left	5.8	
272402 - 2000	Spring, transfer wheel holder		



Part No.	Description	Fig. ref.	Notes
272854 - 2000	Right bracket for cover interlock	5.1	
273134 - 2000	Power switch	5.6, 5.9	
273407 - 2000	Spring for fork, pressure roller arm	5.6	
273559 - 2000	Window for counter		
273939 - 2000	Return spring for pressure roller arm	5.6	
274097A - 2000	Teak cabinet	5.1, 5.2	
274162 - 2000	Socket for radio in/output, DIN	5.2	
274183 - 2000	Spring for cover interlock	5.1	
274535 - 2000	Left bracket for cover interlock	5.1	
275541 - 2000	Motor, 115/230 V AEG	5.8	
277099 - 2000	Bracket, counter lamp	5.7	
277387 - 2000	Motor pulley for AEG motor, 60 Hz	5.7	
277415 - 2000	Screw, acetal, reel lock	2.3, 5.4, 5.5	
277530A - 2000	Spring, reel lock	5.4, 5.5	
278263B - 2000	Walnut cabinet	5.1, 5.2	
279096 - 2000	Housing, reel lock	2.3, 5.4, 5.5	
279126 - 2000	Knob, input level, start/stop	5.1	
280038 - 2000	Lamp for counter and indicator	5.7	
280921 - 2000	Knob, lower, playback/bass	5.1	
280993 - 2000	Knob, operating lever	5.1	
281152 - 2000	Guide plate, push-buttons	5.6	
281267 - 2000	Top cover, front	5.1	
281777 - 2000	Indicator for recording	5.6	
282330 - 2000	Switch, push-buttons	5.7	
282948 - 2000	Rear cover plate, European version	5.2, 5.8	
283522 - 2000	Spacer, tape guide	5.6	
284356 - 2000	Socket for loudspeaker, DIN	5.2	
284578 - 2000	Spring, tape guide spacer		
284635 - 2000	Knob, upper, playback/treble	5.1	
284866 - 2000	Connector for microphone	5.7	
301826 - 2000	Motor pulley for AEG motor, 50 Hz	5.7	
990204 - 2000	Parallel arm, complete	5.7	
990213 - 2000	Holder for transfer wheel	5.7	
990233 - 2000	Transfer wheel	5.7	
990234 - 2000	Pressure roller	2.15, 5.3, 5.6	
990242 - 2000	Transformer, oscillator, T1		
990305 - 2000	Arm for transfer wheel	5.7	
990312 - 2000	Flywheel with capstan	5.7	
990325 - 2000	Pressure pad	2.11, 2.12, 2.13, 2.14, 5.6	
990330 - 2000	Lifting cam disc w. shaft	5.7	
990346 - 2000	Bracket with shaft, end stop	5.9	
991009 - 2000	Right clutch disc	2.3, 5.5	
991013 - 2000	R & L clutch lever w. screw	2.3, 2.4, 5.4, 5.5, 5.7	
991014 - 2000	R & L brake lever w. screw	2.6, 5.7	
991015 - 2000	Releasing arm w. pulling rod	5.7	
991017 - 2000	Arm for clutch and brake slide	2.3, 2.6, 5.7	
991021 - 2000	Left turntable brake spring w. pad	5.7	
991022 - 2000	Right turntable brake spring w. pad	5.7	
991023 - 2000	Flywheel brake spring w. pad	5.7	
991024 - 2000	Thrust spring for capstan	5.1	
991025 - 2000	Housing for turntable bearing, left and right	5.4, 5.5	
991026 - 2000	Vertical mounting leg w. rubber feet	5.1	
991027 - 2000	Upper flywheel bearing, compl.	2.7, 5.6, 5.9	
991028 - 2000	Record interlock plate w. shaft	5.6, 5.9	
991030 - 2000	Operating lever w. ball	5.7	
991033 - 2000	Mylar sheet w. felt	2.3, 5.4, 5.5	
991035 - 2000	Tape tightening disc, L & R	2.3, 5.4, 5.5	
991039 - 2000	Rear tape path cover	5.1	
991041 - 2000	Rubber drive belt	5.7	
991042 - 2000	Housing for rubber foot	5.1, 5.2	
991048 - 2000	Turntable, left and right	2.3, 2.5, 2.6, 5.7	
991049 - 2000	Clutch disc, left	5.4	
991052 - 2000	Flutter roller	5.3	
991053 - 2000	Tape guide, left	5.6	
991054 - 2000	Tape guide, right	5.6	
991406 - 2000	Pressure roller arm, compl.	5.3, 5.6	
991407 - 2000	Bottom cover, w/legs	5.1, 5.2	
991408 - 2000	Transfer wire, equal. switch, complete	5.8	
993400 - 2000	Board, mains amplifier	5.8	
993401 - 2000	Board, equalizing amplifier	5.8	
993402 - 2000	Board, input/output connectors	5.8	
993403 - 2000	Set of knobs, complete	5.1	
993404 - 2000	Front tape path cover	5.1	



6.1.1 Screws, Washers, Nuts, and Circlips

Screws		Washers		
261885 - 2000	2 x 5 mm	230542 - 2000	2.3 mm	DIN 6799
214270 - 2000	2.6 x 4 mm	239651 - 2000	3.2 mm	DIN 6799
270002 - 2000	2.6 x 10 mm	235937 - 2000	4 mm	DIN 6799
210556 - 2000	3 x 3 mm	214895 - 2000	4.2 x 7.5 x 0.3 mm	Turbax
269255 - 2000	3 x 4 mm	204013 - 2000	4.2 x 7.5 x 0.5 mm	Turbax
215951 - 2000	3 x 5 mm	217856 - 2000	5.2 x 7.5 x 0.2 mm	Turbax
204809 - 2000	3 x 8 mm	200299 - 2000	5.2 x 7.5 x 0.5 mm	Turbax
263688 - 2000	3 x 8 mm			
217632 - 2000	3 x 10 mm			
261303 - 2000	3 x 10 mm			
261655 - 2000	3 x 10 mm			
210622 - 2000	3 x 18 mm			
206908 - 2000	3 x 20 mm			
204658 - 2000	4 x 6 mm			
		Nuts		
232367 - 2000	3/16" No. 4	209566 - 2000	2.6 mm	
200944 - 2000	1/4" No. 4	266733 - 2000	3 mm	
231267 - 2000	1/4" No. 4	232066 - 2000	Cabinet mounting	
227899 - 2000	1/4" No. 6			
218675 - 2000	3/8" No. 4			
269298 - 2000	1/2" No. 2			
262984 - 2000	5/8" No. 6			
213767 - 2000	3/4" No. 4			
		Circlips		
		236346 - 2000	2 mm	
		212145 - 2000	2.5 mm	
		208431 - 2000	3 mm	
		201003 - 2000	4 mm	
		217540 - 2000	5 mm	
		213826 - 2000	6 mm	



## 6.2 Electrical Parts

### 6.2.1 Resistors

Ref. No.	Description	Notes
R101 - 2000	47 kohm 1/3 W 5 %	
R102 - 2000	47 kohm 1/2 W 5 %	
R103 - 2000	10 kohm 1/3 W 10 %	
R104 - 2000	220 kohm 1/2 W 5 %	
R106 - 2000	150 ohm 1/2 W 5 %	
R107 - 2000	100 kohm 1/2 W 5 %	
R108 - 2000	10 kohm 1/3 W 10 %	
R109 - 2000	1.8 kohm 1/3 W 10 %	
R110 - 2000	120 kohm 1/2 W 5 %	
R111 - 2000	560 ohm 1/2 W 5 %	
R112 - 2000	10 kohm 1/3 W 10 %	
R113 - 2000	1 kohm 1/3 W 10 %	Valid above serial No. 2362380
R114 - 2000	1 kohm 1/2 W 5 %	
R115 - 2000	1 kohm 1/3 W 10 %	
R116 - 2000	1 kohm 1/3 W 5 %	
R120 - 2000	5.6 kohm 1/3 W 10 %	
R122 - 2000	2.2 kohm 1/3 W 10 %	
R123 - 2000	18 kohm 1/4 W 5 %	
R124 - 2000	150 kohm 1/3 W 10 %	
R126 - 2000	1.5 kohm 1/3 W 5 %	
R128 - 2000	1 Mohm 1/3 W 10 %	
R129 - 2000	560 kohm 1/3 W 10 %	
R130 - 2000	150 kohm 1/3 W 10 %	
R131 - 2000	5.6 kohm 1/3 W 10 %	
R132 - 2000	100 ohm 1/2 W 10 %	
R133 - 2000	8.2 kohm 1/3 W 10 %	
R134 - 2000	220 ohm 1/3 W 10 %	Removed from serial No. 2662380
R135 - 2000	2.2 kohm 1/3 W 10 %	
R136 - 2000	2.2 kohm 1/3 W 10 %	
R137 - 2000	180 ohm 1/3 W 10 %	
R138 - 2000	180 ohm 1/3 W 10 %	
R139 - 2000	1 ohm 2 W 10 %	Wirewound
R140 - 2000	1 ohm 2 W 10 %	Wirewound
R141 - 2000	10 ohm 1/3 W 10 %	
R201 - 2000	47 kohm 1/3 W 10 %	
R202 - 2000	47 kohm 1/3 W 5 %	
R203 - 2000	10 kohm 1/3 W 10 %	
R204 - 2000	220 kohm 1/3 W 5 %	
R206 - 2000	150 kohm 1/3 W 5 %	
R207 - 2000	100 kohm 1/3 W 5 %	
R208 - 2000	10 kohm 1/3 W 10 %	
R209 - 2000	1.8 kohm 1/3 W 10 %	
R210 - 2000	120 kohm 1/3 W 5 %	
R211 - 2000	560 ohm 1/2 W 5 %	
R212 - 2000	10 kohm 1/3 W 10 %	Valid above serial No. 2362380
R213 - 2000	1 kohm 1/3 W 5 %	
R214 - 2000	1 kohm 1/4 W 5 %	
R215 - 2000	1 kohm 1/3 W 5 %	
R216 - 2000	1 kohm 1/3 W 5 %	
R220 - 2000	5.6 kohm 1/3 W 10 %	
R220 - 2000	2.2 kohm 1/2 W 10 %	
R223 - 2000	18 kohm 1/4 W 5 %	
R224 - 2000	150 kohm 1/3 W 10 %	
R226 - 2000	1.5 kohm 1/3 W 5 %	
R228 - 2000	1 Mohm 1/3 W 10 %	
R229 - 2000	560 kohm 1/3 W 10 %	
R230 - 2000	150 kohm 1/3 W 10 %	
R231 - 2000	5.6 kohm 1/3 W 10 %	
R232 - 2000	100 ohm 1/3 W 10 %	
R233 - 2000	8.2 kohm 1/3 W 10 %	
R234 - 2000	220 ohm 1/3 W 10 %	Removed from serial No. 2362380
R235 - 2000	2.2 kohm 1/3 W 10 %	
R236 - 2000	2.2 kohm 1/3 W 10 %	
R237 - 2000	108 ohm 1/3 W 10 %	
R238 - 2000	180 ohm 1/3 W 10 %	
R239 - 2000	1 ohm 2 W 10 %	Wirewound
R240 - 2000	1 ohm 2 W 10 %	Wirewound
R241 - 2000	10 ohm 1/3 W 10 %	
R317 - 2000	15 kohm 1/3 W 5 %	
R318 - 2000	680 ohm 1/3 W 5 %	
R319 - 2000	82 kohm 1/3 W 5 %	
R320 - 2000	1.5 kohm 1/3 W 5 %	
R321 - 2000	120 kohm 1/3 W 5 %	
R322 - 2000	1 kohm 1/3 W 5 %	
R323 - 2000	10 kohm 1/3 W 5 %	
R324 - 2000	1 kohm 1/3 W 5 %	
R325 - 2000	15 kohm 1/3 W 5 %	
R326 - 2000	2.7 kohm 1/3 W 5 %	
R327 - 2000	820 ohm 1/3 W 5 %	
R328 - 2000	820 ohm 1/3 W 5 %	



Ref. No.	Description	Notes
R329 - 2000	220 ohm 1/3 W 5 %	
R330 - 2000	470 ohm 1/3 W 5 %	
R331 - 2000	270 ohm 1/3 W 5 %	
R332 - 2000	3.3 kohm 1/3 W 10 %	4-track version
R332 - 2000	2.7 kohm 1/3 W 10 %	2-track version
R334 - 2000	1 Mohm 1/3 W 5 %	
R335 - 2000	15 kohm 1/3 W 5 %	
R336 - 2000	6.8 kohm 1/2 W 5 %	
R339 - 2000	680 kohm 1/3 W 5 %	
R340 - 2000	5.6 kohm 1/3 W 5 %	
R341 - 2000	330 kohm 1/3 W 10 %	
R342 - 2000	3.3 kohm 1/3 W 5 %	
R343 - 2000	3.3 kohm 1/2 W 5 %	
R344 - 2000	1.5 kohm 1/3 W 5 %	
R345 - 2000	680 kohm 1/3 W 5 %	
R346 - 2000	220 ohm 1/3 W 5 %	
R347 - 2000	68 kohm 1/3 W 5 %	
R348 - 2000	22 kohm 1/3 W 5 %	
R349 - 2000	3.3 kohm 1/3 W 5 %	
R350 - 2000	2.2 kohm 1/3 W 5 %	
R352 - 2000	820 kohm 1/3 W 5 %	Valid above serial No. 2361300
R353 - 2000	56 kohm 1/3 W 5 %	
R354 - 2000	10 kohm 1/3 W 5 %	
R355 - 2000	330 ohm 1/3 W 5 %	
R356 - 2000	470 ohm 1/3 W 10 %	Valid above serial No. 2361300
R357 - 2000	1 kohm 1/3 W 10 %	
R358 - 2000	680 ohm 1/3 W 10 %	
R359 - 2000	1 kohm 1/3 W 10 %	Introduced from serial No. 2361300
R417 - 2000	15 kohm 1/3 W 5 %	Introduced from serial No. 2361300
R418 - 2000	680 ohm 1/3 W 5 %	
R419 - 2000	82 kohm 1/3 W 5 %	
R420 - 2000	1.5 kohm 1/3 W 5 %	
R421 - 2000	120 kohm 1/3 W 5 %	
R422 - 2000	1 kohm 1/3 W 5 %	
R423 - 2000	10 kohm 1/3 W 5 %	
R424 - 2000	1 kohm 1/3 W 5 %	
R425 - 2000	15 kohm 1/3 W 5 %	
R426 - 2000	2.7 kohm 1/3 W 5 %	
R427 - 2000	820 ohm 1/3 W 5 %	
R428 - 2000	820 ohm 1/3 W 5 %	
R429 - 2000	220 ohm 1/3 W 5 %	
R430 - 2000	470 ohm 1/3 W 5 %	
R431 - 2000	270 ohm 1/3 W 5 %	
R432 - 2000	3.3 kohm 1/3 W 5 %	4-track version
R432 - 2000	2.7 kohm 1/3 W 5 %	4-track version
R434 - 2000	1 Mohm 1/3 W 5 %	
R436 - 2000	6.8 kohm 1/3 W 5 %	
R439 - 2000	680 kohm 1/3 W 5 %	
R440 - 2000	5.6 kohm 1/3 W 5 %	
R441 - 2000	330 kohm 1/3 W 5 %	
R442 - 2000	3.3 kohm 1/3 W 5 %	
R443 - 2000	3.3 kohm 1/3 W 5 %	
R444 - 2000	1.5 kohm 1/3 W 5 %	
R445 - 2000	680 kohm 1/3 W 5 %	
R446 - 2000	220 ohm 1/3 W 5 %	
R447 - 2000	68 kohm 1/3 W 5 %	
R448 - 2000	22 kohm 1/3 W 5 %	
R449 - 2000	3.3 kohm 1/3 W 5 %	
R450 - 2000	2.2 kohm 1/3 W 5 %	
R452 - 2000	820 kohm 1/3 W 10 %	Valid above serial No. 2361300
R453 - 2000	56 kohm 1/3 W 5 %	
R454 - 2000	10 kohm 1/3 W 10 %	
R455 - 2000	330 ohm 1/3 W 5 %	
R456 - 2000	470 ohm 1/3 W 10 %	
R457 - 2000	1 kohm 1/3 W 5 %	Valid above serial No. 2361300
R458 - 2000	680 ohm 1/3 W 10 %	
R459 - 2000	1 kohm 1/3 W 10 %	Introduced from serial No. 2361300
R501 - 2000	1 kohm 1/4 W 5 %	Introduced from serial No. 2361300
R502 - 2000	10 ohm 1/3 W 10 %	Valid above serial No. 2362380
R503 - 2000	150 ohm 1/3 W 10 %	Valid above serial No. 2362380
R504 - 2000	150 ohm 1/3 W 10 %	
R505 - 2000	82 ohm 1/3 W 10 %	
R506 - 2000	82 ohm 1/3 W 10 %	
R507 - 2000	47 kohm 1/3 W 10 %	
R508 - 2000	47 kohm 1/3 W 10 %	
R509 - 2000	82 ohm 1/3 W 10 %	
R510 - 2000	560 ohm 1/3 W 10 %	
R511 - 2000	1 kohm 1/3 W 5 %	
R512 - 2000	1.8 kohm 1 W 10 %	
R513 - 2000	470 ohm 1 W 10 %	
R514 - 2000	150 kohm 1/3 W 10 %	



6.2.2 Capacitors

Ref. No.	Description	Type	Notes
C101 - 2000	0.1 μF 100 V 20 %	Metallized polyester	
C102 - 2000	180 pF 500 V 10 %	Ceramic	
C103 - 2000	22 μF 35 V - 10/+ 100 %	Electrolytic	
C104 - 2000	39 pF 500 V 10 %	Ceramic	
C105 - 2000	100 μF 25 V - 10/+ 100 %	Electrolytic	
C106 - 2000	100 μF 25 V - 10/+ 100 %	Electrolytic	
C107 - 2000	4700 pF 100 V 10 %	Metallized polyester	
C120 - 2000	3300 pF 100 V 20 %	Metallized polyester	
C121 - 2000	0.033 μF 100 V 20 %	Metallized polyester	
C122 - 2000	0.022 μF 100 V 20 %	Metallized polyester	
C123 - 2000	0.1 μF 100 V 20 %	Metallized polyester	
C124 - 2000	0.1 μF 100 V 20 %	Metallized polyester	
C125 - 2000	470 pF 500 V 20 %	Ceramic	
C126 - 2000	2.2 μF 63 V - 10/+ 100 %	Electrolytic	
C127 - 2000	47 μF 35 V - 10/+ 100 %	Electrolytic	
C128 - 2000	47 μF 35 V - 10/+ 100 %	Electrolytic	
C129 - 2000	1000 μF 25 V - 10/+ 50 %	Electrolytic	
C130 - 2000	0.1 μF 100 V 20 %	Metallized polyester	
C201 - 2000	0.1 μF 100 V 20 %	Metallized polyester	
C202 - 2000	180 pF 500 V 10 %	Ceramic	
C203 - 2000	22 μF 35 V - 10/+ 100 %	Electrolytic	
C204 - 2000	39 pF 500 V 10 %	Ceramic	
C205 - 2000	100 μF 25 V - 10/+ 100 %	Electrolytic	
C206 - 2000	100 μF 25 V - 10/+ 100 %	Electrolytic	
C207 - 2000	4700 pF 100 V 10 %	Metallized polyester	
C220 - 2000	3300 pF 100 V 20 %	Metallized polyester	
C221 - 2000	0.033 μF 100 V 20 %	Metallized polyester	
C222 - 2000	0.022 μF 100 V 20 %	Metallized polyester	
C223 - 2000	0.1 μF 100 V 20 %	Metallized polyester	
C224 - 2000	0.1 μF 100 V 20 %	Metallized polyester	
C225 - 2000	470 pF 500 V 20 %	Ceramic	
C226 - 2000	2.2 μF 63 V - 10/+ 100 %	Electrolytic	
C227 - 2000	47 μF 35 V - 10/+ 100 %	Electrolytic	
C228 - 2000	47 μF 35 V - 10/+ 100 %	Electrolytic	
C229 - 2000	1000 μF 25 V - 10/+ 50 %	Electrolytic	
C230 - 2000	0.1 μF 100 V 20 %	Metallized polyester	
C309 - 2000	2.2 μF 63 V - 10/+ 100 %	Electrolytic	
C310 - 2000	22 μF 35 V - 10/+ 100 %	Electrolytic	
C311 - 2000	470 pF 500 V 20 %	Ceramic	
C312 - 2000	0.22 μF 250 V 10 %	Metallized polyester	
C313 - 2000	0.022 μF 100 V 10 %	Metallized polyester	
C314 - 2000	0.15 μF 100 V 5 %	Metallized polyester	
C315 - 2000	0.022 μF 100 V 5 %	Metallized polyester	
C316 - 2000	0.01 μF 100 V 10 %	Metallized polyester	
C317 - 2000	0.01 μF 100 V 10 %	Metallized polyester	
C318 - 2000	2.2 μF 63 V - 10/+ 100 %	Electrolytic	
C319 - 2000	2.2 μF 63 V - 10/+ 100 %	Electrolytic	
C320 - 2000	47 μF 35 V - 10/+ 100 %	Electrolytic	
C321 - 2000	22 pF 400 V 20 %	Ceramic	
C322 - 2000	470 pF 500 V 20 %	Ceramic	
C323 - 2000	100 pF 400 V 10 %	Ceramic	
C324 - 2000	0.01 μF 100 V 10 %	Metallized polyester	
C325 - 2000	100 μF 25 V - 10/+ 100 %	Electrolytic	
C326 - 2000	470 pF 500 V 20 %	Ceramic	
C327 - 2000	10 μF 63 V - 10/+ 100 %	Electrolytic	
C328 - 2000	470 μF 3 V - 10/+ 100 %	Electrolytic	
C329 - 2000	100 μF 25 V - 10/+ 100 %	Electrolytic	
C330 - 2000	0.1 μF 100 V 10 %	Metallized polyester	
C331 - 2000	100 μF 25 V - 10/+ 100 %	Electrolytic	
C332 - 2000	470 pF 500 V 20 %	Metallized polyester	
C333 - 2000	100 μF 25 V - 10/+ 100 %	Electrolytic	
C334 - 2000	68 pF 400 V 10 %	Ceramic	
C409 - 2000	2.2 μF 63 V - 10/+ 100 %	Electrolytic	
C410 - 2000	22 μF 35 V - 10/+ 100 %	Electrolytic	
C411 - 2000	470 pF 500 V 20 %	Ceramic	
C412 - 2000	0.22 μF 250 V 10 %	Polyester	
C413 - 2000	0.022 μF 100 V 10 %	Metallized polyester	
C414 - 2000	0.15 μF 100 V 5 %	Metallized polyester	
C415 - 2000	0.22 μF 100 V 5 %	Metallized polyester	
C416 - 2000	0.01 μF 100 V 10 %	Metallized polyester	
C417 - 2000	0.01 μF 100 V 10 %	Metallized polyester	
C418 - 2000	2.2 μF 63 V - 10/+ 100 %	Electrolytic	
C419 - 2000	2.2 μF 63 V - 10/+ 100 %	Electrolytic	
C420 - 2000	47 μF 35 V - 10/+ 100 %	Electrolytic	
C421 - 2000	22 pF 400 V 10 %	Ceramic	
C422 - 2000	470 pF 500 V 20 %	Ceramic	
C423 - 2000	100 pF 400 V 10 %	Ceramic	
C424 - 2000	0.01 μF 100 V 10 %	Metallized polyester	
C425 - 2000	100 μF 25 V - 10/+ 100 %	Electrolytic	
C426 - 2000	470 pF 500 V 20 %	Ceramic	
C427 - 2000	10 μF 63 V - 10/+ 100 %	Electrolytic	
C428 - 2000	470 μF 3 V - 10/+ 100 %	Electrolytic	
C429 - 2000	100 μF 25 V - 10/+ 100 %	Electrolytic	
C430 - 2000	0.1 μF 250 V 10 %	Polyester	
C431 - 2000	100 μF 25 V - 10/+ 100 %	Electrolytic	



Ref. No.	Description	Type	Notes
C432 - 2000	470 pF 500 V 20 %	Ceramic	
C433 - 2000	100 $\mu$ F 25 V - 10/+ 100 %	Electrolytic	
C434 - 2000	68 pF 400 V 10 %	Ceramic	
C501 - 2000	100 $\mu$ F 25 V - 10/+ 100 %	Electrolytic	
C502 - 2000	270 pF 500 V 10 %	Ceramic	
C503 - 2000	470 pF 500 V 20 %	Ceramic	
C504 - 2000	1000 pF 63 V 5 %	Metallized polyester	
C505 - 2000	1000 pF 63 V 5 %	Metallized polyester	
C506 - 2000	1000 $\mu$ F 35/40 V - 10/+ 100 %	Electrolytic	
C507 - 2000	1000 $\mu$ F 50/60 V - 10/+ 100 %	Electrolytic	
C508 - 2000	0.1 $\mu$ F 100 V 20 %	Metallized polyester	
C509 - 2000	0.1 $\mu$ F 100 V 20 %	Metallized polyester	
C510 - 2000	10-40 pF	Ceramic	Trimming
C511 - 2000	10-40 pF	Ceramic	Trimming
C512 - 2000	22 pF 400 V 10 %	Ceramic	
C513 - 2000	22 pF 400 V 10 %	Ceramic	
C514 - 2000	3300 pF 63 V 2.5 %	Metallized polyester	Introduced from serial No. 2360700
C515 - 2000	3300 pF 63 V 2.5 %	Metallized polyester	Introduced from serial No. 2360700

### 6.2.3 Potentiometers

Ref. No.	Description	Notes
R105 - 2000	1 Mohm Positive exponent.	
R117 - 2000	10 kohm Linear	
R121 - 2000	4 x 100 kohm Linear	
R125 - 2000	4 x 100 kohm Linear	
R127 - 2000	2 x 10 kohm Positive logarithm.	
R134 - 2000	500 ohm Linear	
R205 - 2000	1 Mohm Positive exponent.	Introduced from serial No. 2362380
R217 - 2000	10 kohm Linear	
R221 - 2000	4 x 100 kohm Linear	
R225 - 2000	4 x 100 kohm Linear	
R227 - 2000	2 x 10 kohm Positive logarithm.	
R234 - 2000	500 ohm Linear	
R333 - 2000	50 kohm Linear	Introduced from serial No. 2362380
R351 - 2000	1 kohm Linear	
R433 - 2000	50 kohm Linear	
R451 - 2000	1 kohm Linear	

### 6.2.4 Transistors

Ref. No.	Type	Notes
Q101 - 2000	BC 149B	
Q102 - 2000	BC 149B	
Q103 - 2000	BC 148A - BC 208A	
Q120 - 2000	BC 148A - BC 208A	
Q121 - 2000	2N 4126	
Q122 - 2000	BC 107B	
Q123 - 2000	BC 177B	
Q124 - 2000	BD 176	
Q125 - 2000	BD 175	
Q201 - 2000	BC 149B	
Q202 - 2000	BC 149B	
Q203 - 2000	BC 148A - BC 208A	
Q204 - 2000	BC 148A - BC 208A	
Q221 - 2000	2N 4126	
Q222 - 2000	BC 107B	
Q223 - 2000	BC 177B	
Q224 - 2000	BD 176	
Q225 - 2000	BD 175	
Q301 - 2000	BC 148A - BC 208A	
Q302 - 2000	BC 148A - BC 208A	
Q303 - 2000	BC 107B	
Q304 - 2000	BC 147B	
Q305 - 2000	BC 149C	
Q306 - 2000	BC 149C	
Q307 - 2000	BC 147B	
Q308 - 2000	BC 148B - BC 208B	



Ref. No.	Description	Notes
Q309 - 2000	BC 107B	
Q401 - 2000	BC 148B - BC 208B	
Q402 - 2000	BC 148B - BC 208B	
Q403 - 2000	BC 107B	
Q404 - 2000	BC 147B	
Q405 - 2000	BC 149B	
Q406 - 2000	BC 149B	
Q407 - 2000	BC 147B	
Q408 - 2000	BC 148B - BC 208B	
Q409 - 2000	BC 107B	
Q501 - 2000	U 2848/1	
Q502 - 2000	U 2848/1	
Q503 - 2000	BC 147B	
Q504 - 2000	BC 107B	
Q505 - 2000	MJE 371	

#### 6.2.5 Heads

Ref. No.	Description	Notes
11R - F53 - 2000	Record head	4-track
07R - F82 - 2000	Record head	2-track
10P - C03 - 2000	Playback head	4-track
11P - F83 - 2000	Playback head	2-track
13E - C44 - 2000	Erase head	4-track
20E - D87 - 2000	Erase head	2-track

#### 6.2.6 Diodes

Ref. No.	Type	Notes
D120 - 2000	1N4148	
D220 - 2000	1N4148	
D501 - 2000	1N4148	
D502 - 2000	1N4148	
D503 - 2000	1N5254B	Zener 27 V



## 7.0 Block Diagram

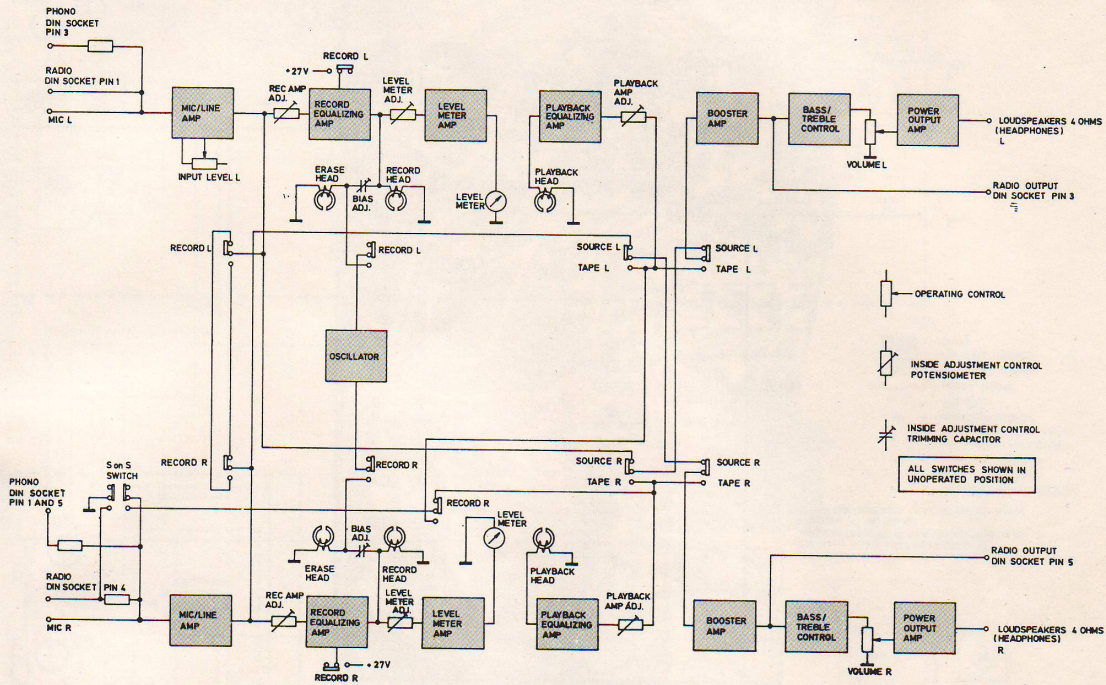

## 8.0 Printed Wiring Boards and Circuit Diagram

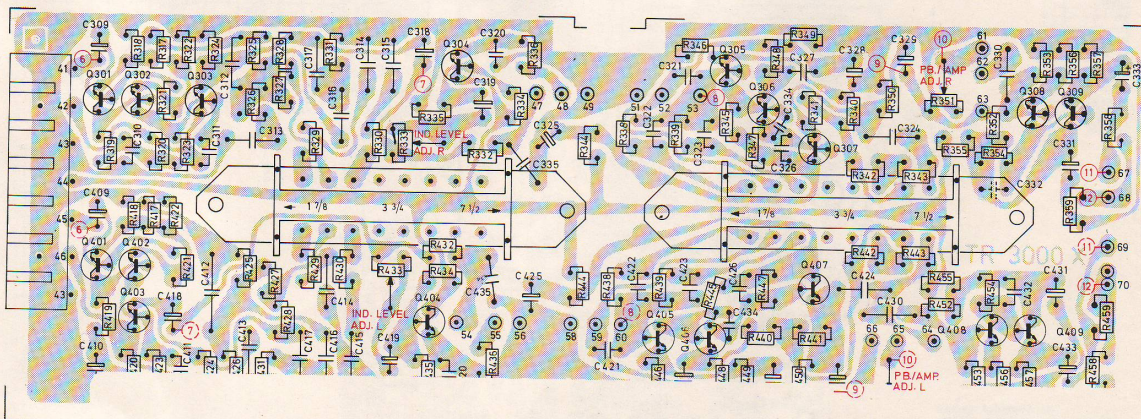

Board for record equalizing amplifiers, level indicator amplifiers, playback equalizing amplifiers and booster amplifiers, channels L and R. Printed side.





Tandbergs Radiofabrikk A/S, Kjelsås.

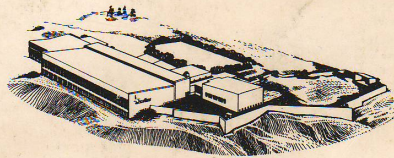

Tandbergs Radiofabrikk A/S, div. Kjeller.

**TANDBERGS RADIOFABRIKK A/S**

P.O.B. 9, Korsvoll, Oslo 8, Norway



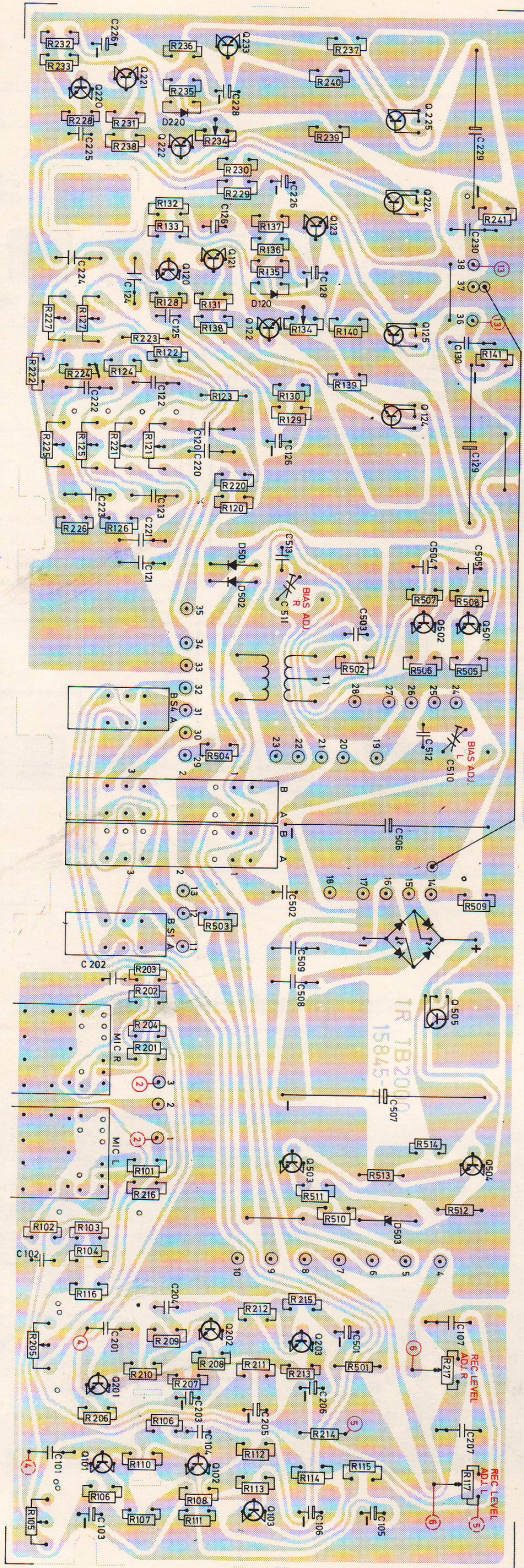

Board for mic/line amplifiers, buffer amplifiers, oscillator, bias and DC voltage regulator, channels L and R. Printed side.

BL  
RO.  
GR.



TABLE OF CONTENTS

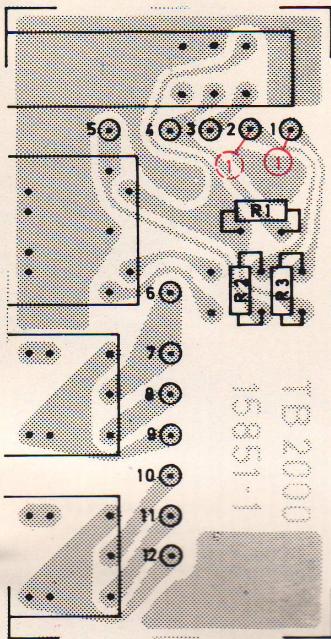

Input and output terminal board,  
channels L and R. Printed side.







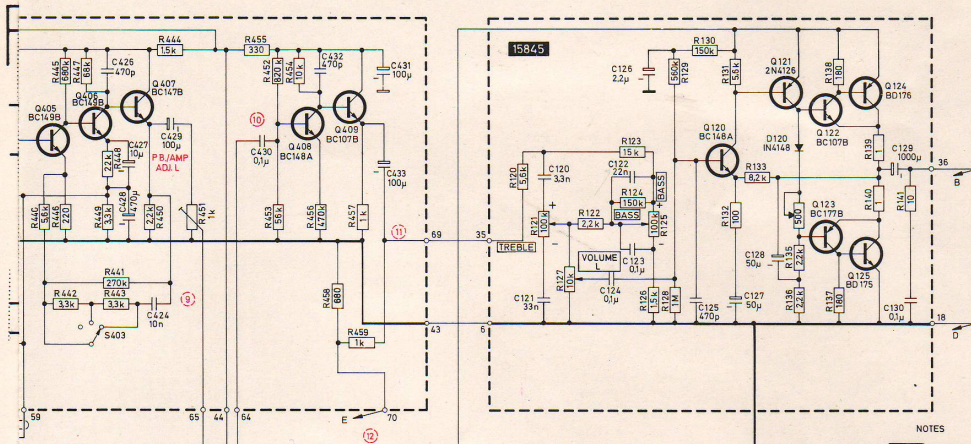

*→ Fuse for feed!  
Pris 25-30 kr*

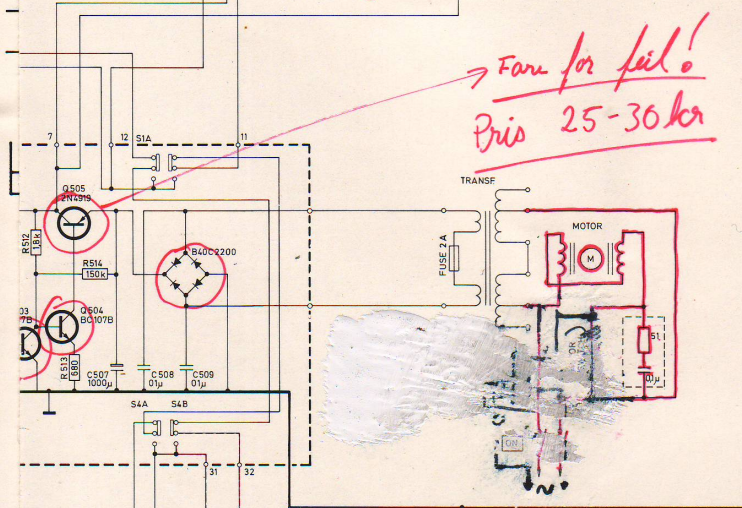

- NOTES
- 15/53 = BOARD
  - MIC L = TOP PLATE MARKING
  - LEFT = REAR PANEL MARKING
  - REC LEVEL = PRESET CONTROL
  - Ⓢ Ⓢ = TEST POINT
  - 24 = CONNECTION TERMINAL
  - L = UPPER TRACK-LEFT CHANNEL
  - R = LOWER TRACK-RIGHT CHANNEL
  - = SIGNAL PATH, PLAYBACK
  - = SIGNAL PATH, RECORD
  - = DEPOSITED CARBON RESISTORS
- CAPACITORS INDICATED IN pF UNLESS OTHERWISE SPECIFIED  
 μ=1000 000 pF  
 RESISTORS INDICATED IN OHMS UNLESS OTHERWISE SPECIFIED  
 k=1000 OHMS M=1000 000 OHMS  
 VOLTAGES GIVEN IN PARENTHESES REFER TO RECORD POSITION

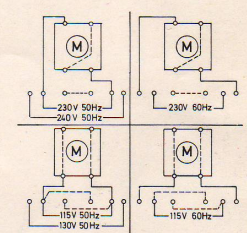

TRANSFORMER AND MOTOR CONNECTIONS

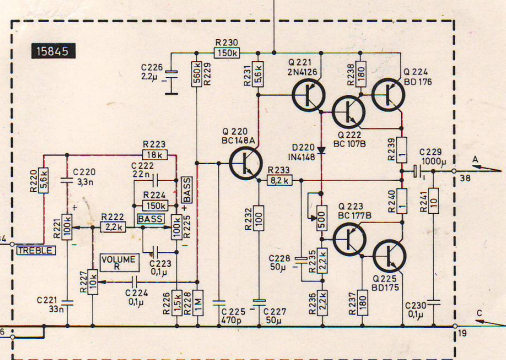
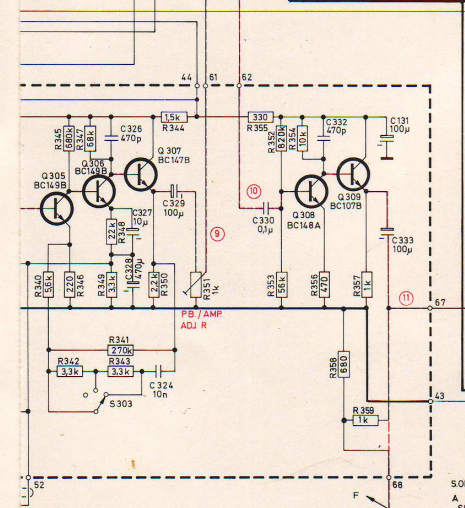

SENSITIVITY	AT 400Hz	MIC / PHONO
1	150mV	4mV
2	75mV	2mV
3	50mV	1.3V
4	30mV	0.75mV
5	20mV	0.5mV
6	15mV	0.35mV
7	10mV	0.25mV
8	7.5mV	0.175mV
9	5mV	0.125mV
10	3.5mV	0.0875mV
11	2.5mV	0.0625mV
12	1.75mV	0.04375mV
13	1.25mV	0.03125mV

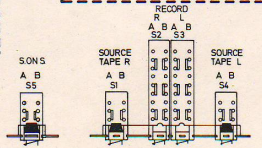

SWITCHES ARE SHOWN IN UNOPERATED POSITION.

Tandbergs Radiofabrik A/S  
 WIRING DIAGRAM FOR TB 2000  
 PART NO. 304018-2