

December 1965

TANDBERG TAPE-RECORDER

MODELS 74-72 and 74B-72B

Service Manual



Tandberg
RADIO

TANDBERGS RADIOFABRIKK A/S - OSLO - NORWAY

Preface

This service manual covers the Tandberg tape recorder models 74 – 72 and 74 B – 72 B.

The model 74 is a complete quarter-track, three speed stereo, record, and playback unit with two heads. It is equipped with separate record and playback preamplifiers for each channel. The combined record/power output amplifiers can be switched between record amplifiers or playback power amplifiers. The model 74 B is similar to the model 74, but is furnished with a playback pre-amplifier output stage, for each channel, in addition to the combined record/power output amplifier, and a center channel output. The model 72 is the half-track version of the model 74. The model 72 B is the half-track version of the model 74 B.

All four models have exactly the same mechanical system.

We hope that everyone concerned with our products will find this service manual useful.

May 1964.

This second edition of the service manual has been changed to incorporate certain modifications which have been made in the tape recorder to improve the equipment.

October 1965.

Contents

	Page		Page
1.0 Technical specification, Tandberg tape recorder models 74 — 72 and 74B — 72B	4	5.1.5 The record/power output amplifier, as power output amplifier	27
2.0 The function of the controls	6	5.1.6 The playback pre-amplifier output stage	28
3.0 The input and output terminals	7	5.1.7 The record level indicator circuit	28
4.0 The mechanism, detailed description and adjustment instruction	8	5.1.8 The oscillator, bias and erase circuit	28
4.1 The operating lever	9	5.1.9 The power supply	29
4.1.1 The motor switch	9	5.2 The switching system	30
4.1.2 The eccentric segment	10	5.2.1 The function selector switch	30
4.1.3 The pressure wheel assembly	10	5.2.2 The speaker selector switch	30
4.1.4 The tape brake	12	5.2.3 Monaural recording on channel 1 or 2	31
4.1.5 The mechanical connection for the muting switch ..	12	5.2.4 Mixing during monaural recording	31
4.1.6 The trip bar	12	5.2.5 Stereo recording	32
4.2 The turntable assemblies	13	5.2.6 Monaural playback, channel 1 or 2	32
4.2.1 The supply turntable assembly	13	5.2.7 Stereo playback	32
4.2.2 The tape tight tension	13	5.2.8 Public address (stereo amplifier)	32
4.2.3 The take-up turntable assembly	14	5.2.9 Add a track	32
4.2.4 Horizontal and vertical alignment of the turntables	15	5.2.10 Sound on sound	32
4.3 Clutch alignments	15	5.3 Head alignment and track control with Tandberg test tapes	33
4.3.1 General	16	5.3.1 The models 74 and 74B	33
4.3.2 Fast rewind	16	5.3.2 The models 72 and 72B	33
4.3.3 Fast wind	17	5.4 Head alignment without Tandberg test tapes	34
4.3.4 Normal forward drive	17	5.4.1 Demagnetizing	34
4.3.5 Neutral	17	5.4.2 The adjustable tape guides	34
4.3.6 Free	18	5.4.3 The record/playback head	34
4.4 The motor pulley	18	5.4.4 The erase head	34
4.4.1 Threading of the rubber drive belt	19	5.5 Track control, models 74 and 74B without Tandberg test tapes	34
4.5 The speed transfer wheel	19	5.5.1 The The record/playback head	34
4.6 The lifting arm	19	5.5.2 The erase head	34
4.7 The flywheel with the capstan	19	5.6 Track control, models 72 and 72B without Tandberg test tapes	34
4.7.1 The brake for the flywheel	20	5.6.1 The erase head	34
4.8 The speed change mechanism	21	5.6.2 The record/playback head	34
4.9 The momentary start-stop feature	21	5.7 Electrical adjustments	34
4.10 The pressure pad	22	5.7.1 Adjustment of the oscillator and erase circuits	34
4.11 The automatic end stop switch	22	5.7.2 Bias adjustment	35
4.12 The revolution counter	22	5.7.3 Adjustment of the recording current and the indicators	35
4.13 Assembling the top cover	22	5.7.4 Adjustment of the FM-multiplex filters	36
5.0 The electronic circuits, detailed description and adjustment instruction	24	5.7.5 Adjustment of the input level set potentiometers ..	36
5.1 The main electronic units, block diagram	24	5.7.6 Playback amplifier test	36
5.1.1 The record pre-amplifier	24	5.7.7 Record amplifier test	36
5.1.2 The FM-multiplex filter	25	5.7.8 Total record and playback response	37
5.1.3 The record/power output amplifier, as record amplifier	25	5.7.9 Speed test	37
5.1.4 The playback pre-amplifier	27	5.7.10 Adjustment of the balance control	37
5.1.5 The record/power output amplifier, as power output amplifier	27	5.8 The distinction between the models 74 — 72 and 74B — 72B	37
5.1.6 The playback pre-amplifier output stage	28	5.9 Modification from quarter-track to half-track models	39
5.1.7 The record level indicator circuit	28	6.0 Parts list	44
5.1.8 The oscillator, bias and erase circuit	28	6.0.1 Mechanical parts	44
5.1.9 The power supply	29	6.0.2 Electrical parts	49
5.2 The switching system	30		
5.2.1 The function selector switch	30		
5.2.2 The speaker selector switch	30		
5.2.3 Monaural recording on channel 1 or 2	31		
5.2.4 Mixing during monaural recording	31		
5.2.5 Stereo recording	32		
5.2.6 Monaural playback, channel 1 or 2	32		
5.2.7 Stereo playback	32		
5.2.8 Public address (stereo amplifier)	32		
5.2.9 Add a track	32		
5.2.10 Sound on sound	32		
5.3 Head alignment and track control with Tandberg test tapes	33		
5.3.1 The models 74 and 74B	33		
5.3.2 The models 72 and 72B	33		
5.4 Head alignment without Tandberg test tapes	34		
5.4.1 Demagnetizing	34		
5.4.2 The adjustable tape guides	34		
5.4.3 The record/playback head	34		
5.4.4 The erase head	34		
5.5 Track control, models 74 and 74B without Tandberg test tapes	34		
5.5.1 The The record/playback head	34		
5.5.2 The erase head	34		
5.6 Track control, models 72 and 72B without Tandberg test tapes	34		
5.6.1 The erase head	34		
5.6.2 The record/playback head	34		
5.7 Electrical adjustments	34		
5.7.1 Adjustment of the oscillator and erase circuits	34		
5.7.2 Bias adjustment	35		
5.7.3 Adjustment of the recording current and the indicators	35		
5.7.4 Adjustment of the FM-multiplex filters	36		
5.7.5 Adjustment of the input level set potentiometers ..	36		
5.7.6 Playback amplifier test	36		
5.7.7 Record amplifier test	36		
5.7.8 Total record and playback response	37		
5.7.9 Speed test	37		
5.7.10 Adjustment of the balance control	37		
5.8 The distinction between the models 74 — 72 and 74B — 72B	37		
5.9 Modification from quarter-track to half-track models	39		
6.0 Parts list	44		
6.0.1 Mechanical parts	44		
6.0.2 Electrical parts	49		

1.0 Technical Specification, Tandberg tape recorder models 74-72 and 74B-72B

Power requirements:	110 - 125 - 145 - 200 - 220 - 245 volts, 50 c/s. U.S. model: 115 volts, 60 c/s.
Power consumption:	85 watts.
Motor:	Four pole, asynchronous capacitor motor.
Tape speed:	$7\frac{1}{2}$, $3\frac{3}{4}$, and $1\frac{7}{8}$ inches per second. The amplifiers are equalized to conform with N.A.B. standards.
Playing time. Models 74 and 74B:	Four-track recordings on 1800 ft. of tape: Tape speed $7\frac{1}{2}$ i.p.s.: Stereo 2 × 48 min. Mono 4 × 48 min. Tape speed $3\frac{3}{4}$ i.p.s.: Stereo 2 × 96 min. Mono 4 × 96 min. Tape speed $1\frac{7}{8}$ i.p.s.: Stereo 2 × 192 min. Mono 4 × 192 min.
Models 72 and 72B:	Two-track recordings on 1800 ft. of tape: Tape speed $7\frac{1}{2}$ i.p.s.: Stereo 48 min. Mono 2 × 48 min. Tape speed $3\frac{3}{4}$ i.p.s.: Stereo 96 min. Mono 2 × 96 min. Tape speed $1\frac{7}{8}$ i.p.s.: Stereo 192 min. Mono 2 × 192 min.
Fast wind and rewind:	The fast wind or rewind time for 1800 feet of tape is approx. 2½ minutes.
Tape path:	The tape moves from the left to the right. The heads are positioned with the air gaps pointing towards the front.
Recording tape:	Maximum reel diameter is 7". Good quality recording tape is recommended.
Automatic stop:	The automatic stop operates during record or playback as well as during fast wind or rewind modes.
Heads. Models 74 and 74B:	Quarter-track erase head. Quarter-track combined record and playback head. Air gap: 0.003 mm (.00012").
Models 72 and 72B:	Half-track erase head. Half-track combined record and playback head. Air gap: 0.003 mm (.00012").
Frequency response:	$7\frac{1}{2}$ i.p.s. 30–20 000 c/s (± 2 dB 40–16 000 c/s). $3\frac{3}{4}$ i.p.s. 30–14 000 c/s (± 2 dB 60–10 000 c/s). $1\frac{7}{8}$ i.p.s. 50– 7 000 c/s (± 2 dB 80– 5 000 c/s). In «AMPLIFIER» position: 40–16 000 c/s ± 2 dB.
Distortion:	The distortion from the tape recorded with a 400 c/s signal at maximum recording level is less than 5 % when played back.
Signal to noise ratio, Models 74 and 74B:	The signal to noise ratio is better than 53 dB with the tape recorded to 5 % distortion.
Models 72 and 72B:	The signal to noise ratio is better than 55 dB with the tape recorded to 5 % distortion.

Crosstalk:	The crosstalk rejection is better than 60 dB at 400 c/s.
Wow and flutter:	Better than .15 % at 7 ¹ / ₂ i.p.s. tape speed. Better than .2 % at 3 ³ / ₄ i.p.s. tape speed. Better than .3 % at 1 ⁷ / ₈ i.p.s. tape speed.
Erase and bias frequency:	The erase and bias frequency is 85.5 kc/s. The even harmonic distortion in the bias current is less than .5 %.
Recording level indicator:	The electronic beam indicator range is 20 dB plus overload, and is adjusted for maximum indication at 5 % distortion recorded on the tape. The indicators are equipped with damping circuits.
Input impedance:	Microphone input ch. 1 and ch. 2: Input impedance: 3 Mohm. Minimum input signal for maximum recording level at 1000 c/s: 2–2.5 mV. Maximum input voltage: 50 mV. Line inputs ch. 1 and ch. 2: Input impedance: between .1–.5 Mohm. Adjustable sensitivity: 2.5 mV–7V. Maximum input signal 7 V. FM-Multiplex inputs: 19 kc/s FM-multiplex filters are furnished on tape recorders sold in certain territories.
Playback pre-amplifier output:	Two playback pre-amplifier outputs are provided for connection to pre-amplifiers. Minimum load impedance: 100 kohm.
Low impedance output:	Two phono plugs are provided for connection of external speakers. Impedance: 4 ohm.
Center channel output:	Impedance: Min. 400 ohms.
Power output:	A tape recorded to maximum recording level (5 % distortion) will give an power output of 3 watts in each channel when played back at maximum output level.
Speakers:	Two speakers 7" × 4".
Bass switch:	The amplification will increase 8 dB at 100 c/s in playback or amplification modes, when the bass switch is set to «BASS» position. This increase of the low frequency amplification will only be present on the channel which is set up for playback or amplification even when the other channel is connected for recording.
Momentary start-stop lever:	The momentary start-stop lever starts or stops the recording or playback instantly.
Counter:	The 4 digit counter shows the number of revolutions of the take-up turntable.
Tubes. Models 72 and 74:	1 ECC 82 (12AU7), 2 ECC 83 (12AX7), 2 ECL 86 (6GW8), 2 EAM 86.
Models 72B and 74B:	1 ECC 82 (12AU7), 4 ECC 83 (12AX7), 2 EL 84 (6BQ5), 2 EAM 86.
Transistors:	2 AC107.
Rectifier:	One high voltage rectifier (B250 – C125).
Dimensions:	Teak cabinet 15 ³ / ₈ " long, 11 ¹³ / ₁₆ " wide, and 5 ⁷ / ₈ " high.
Weight:	Instrument alone 27.6 lbs, with carrying case 32.6 lbs.

2.0 The function of the controls

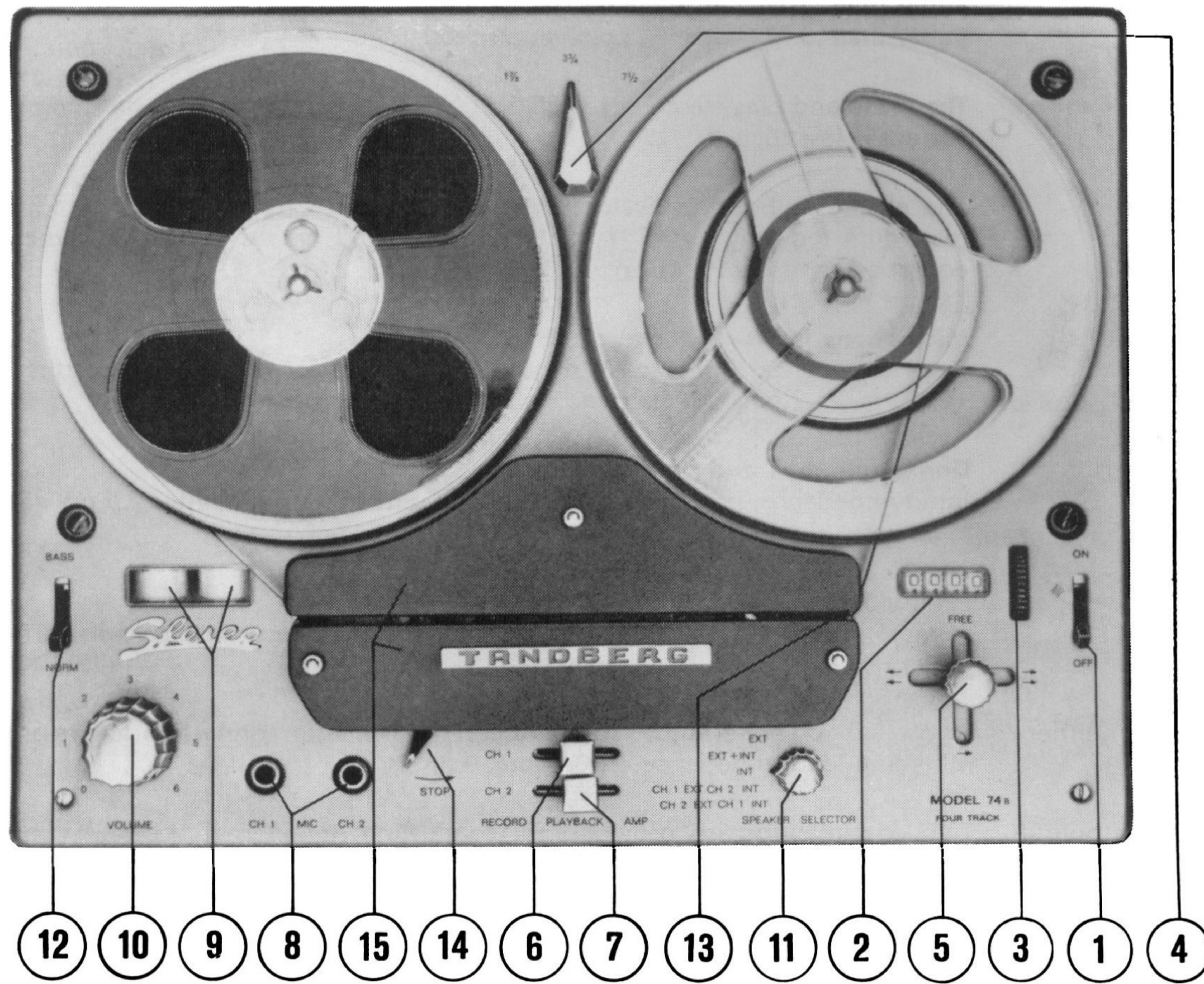

Fig. 1. The operating controls.

1. Power switch
2. Tape counter: indicates the position of the tape.
3. Re-set wheel: re-sets the tape counter to zero.
4. Speed selector: selects the required tape speed.
5. Operating lever: activates the mechanism in the tape recorder for the different modes of operation.
6. Function selector switch channel 1: activates the electronic circuits for record, playback, or amplifier modes, channel 1.
7. Function selector switch channel 2: activates the electronic circuits for record, playback, or amplifier modes, channel 2.
8. Microphone inputs: high impedance microphone inputs channel 1 and channel 2.
9. Record level indicators: indicates the recording level. Maximum recording level is obtained when the electronic beam indicators are closed.
left indicator: Channel 1 (upper track).
right indicator: Channel 2 (lower track).
10. Volume controls: controls the record gain in record mode and the output volume in playback mode.
Upper knob: Channel 1 (upper track).
Lower knob: Channel 2 (lower track).

11. Speaker selector switch.

Models 74 and 72: EXT: External speakers only.
 INT + EXT: Internal and external speakers.
 INT: Internal speakers only.

or:
 EXT: External speakers only.
 INT + EXT: Internal and external speakers.
 INT: Internal speakers only.
 CH. 2 INT: The output from ch. 2 is connected to both internal speakers.
 CH. 1 INT: The output from ch. 1 is connected to both internal speakers.

Models 74B and 72B:
 EXT: External speakers only.
 EXT + INT: External and internal speakers.
 INT: Internal speakers only.
 CH.1 EXT, CH. 2 INT: The output from ch. 1 is connected to both external speaker terminals. The output from ch. 2 is connected to both internal speakers.
 CH. 2 EXT, CH. 1 INT: The output from ch. 2 is connected to both external speaker terminals. The output from ch. 1 is connected to both internal speakers.

12. Bass switch: increases the amplification 8 dB at 100 c/s with the switch in «BASS» position. The frequency response will be straight when the switch is in «NORM» position. The switch is operative in playback mode, and in AMP position.

13. Automatic end stop switch: stops the motor when the tape runs out or if the tape breaks.

14. Momentary start-stop switch: stops the recording or playback instantly when the lever is moved to the right position. The record or playback will start immediately when the lever is moved to the left position.

15. Front and rear trim covers: remove the trim covers to clean or demagnetize the heads.

3.0 The input and output terminals

The input and output terminals, together with the input level set potentiometers are located at the rear of the tape recorder, ref. fig. 2 for the models 72 and 74 and fig. 3 for the models 72B and 74B.

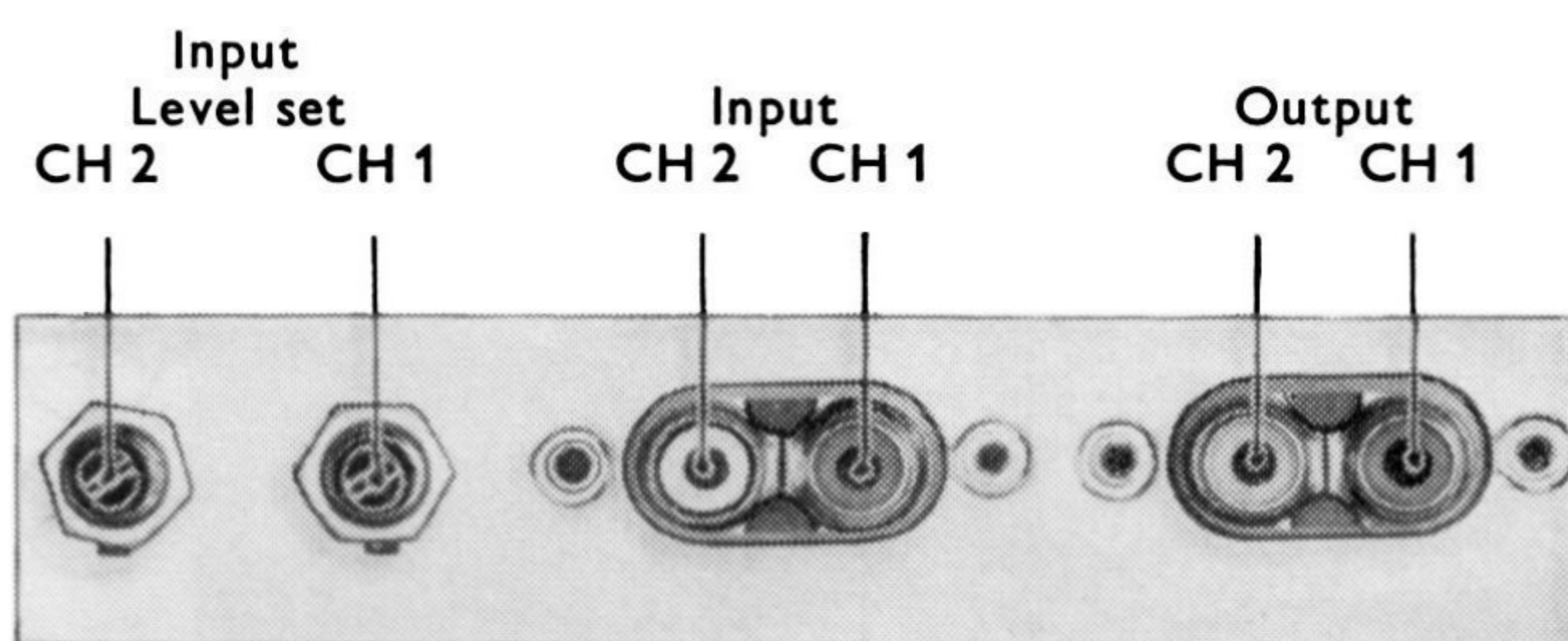

Fig. 2. The input and output terminals, models 74 and 72.

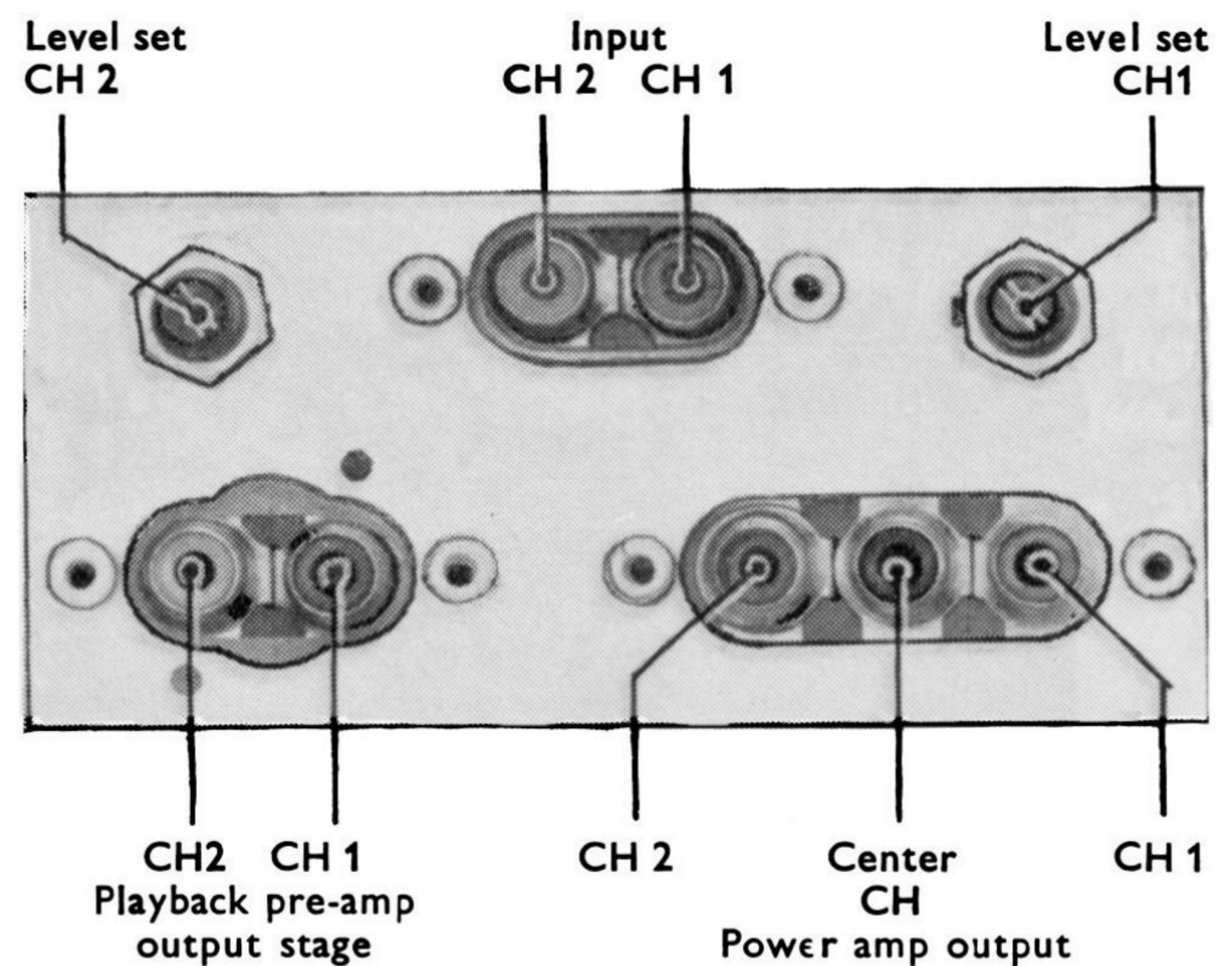

Fig. 3. The input and output terminals, models 74B and 72B.

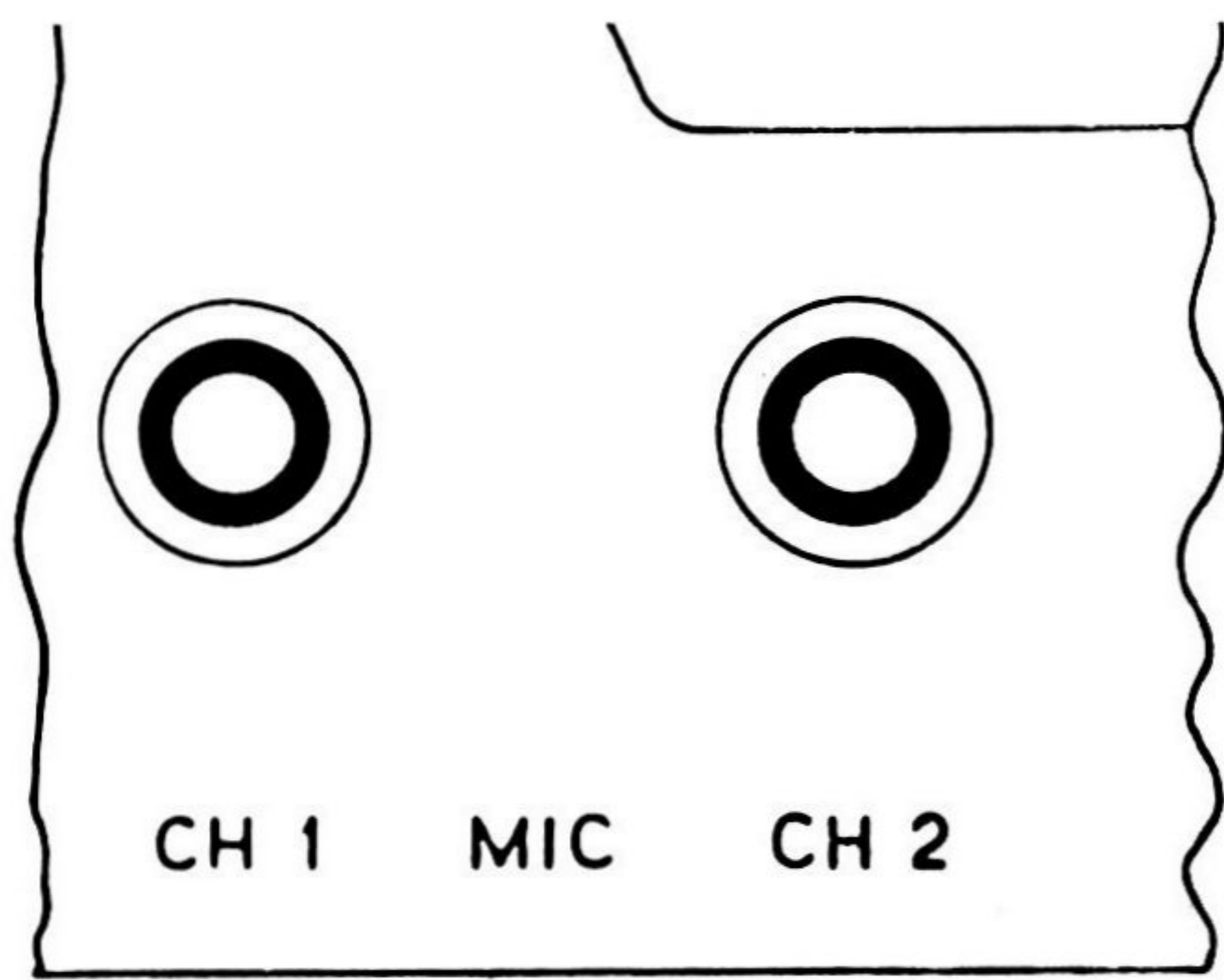

Fig. 4. The microphone inputs.

Microphone inputs

The microphone jacks are located below the front trim cover on top of the recorder, ref. fig. 4.

Input impedance: 3 Mohms.
 Max. input voltage: 50 mV.
 Minimum input signal for max. recording level at 1000 c/s: 2–2.5 mV.

4.0 The mechanism, detailed description and adjustment instruction

The models 74 – 72 and 74B – 72B have exactly the same mechanical system. The main function of the mechanical system is to drive

the turntables and the capstan in the different modes of tape motion. The mechanical function is activated by the operating lever.

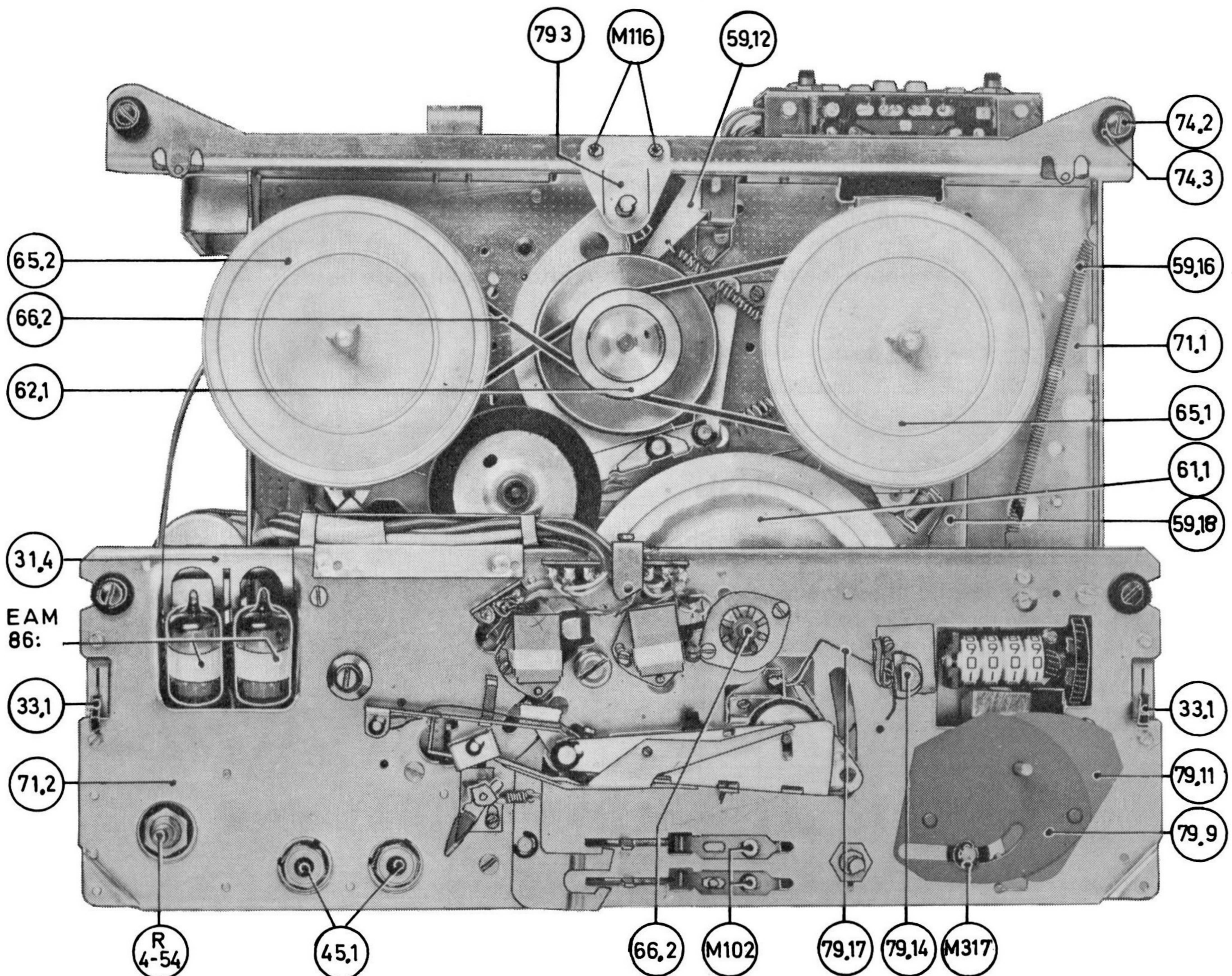

Fig. 5. Top view, with top cover removed.

Note: Ref. fig. 53 for tape recorders with serial No. below 720 000.

4.1 THE OPERATING LEVER

The operating lever (54.1) has five positions and is located at the right front corner of the tape recorder: Normal forward drive, fast forward drive, fast rewind, free, and neutral.

The operating lever activates the following parts:

The motor switch (33.2): disconnects the power to the motor (14.1) in neutral or free position of the operating lever.

The eccentric segment (59.17): guides the pressure wheel assembly (51.3) and the lifting arm (59.18).

The trip bar (52.1): activates the clutches under both turntables (65.1, 65.2).

4.1.1 The motor switch

The microswitch (33.2) is located on the bracket (54.9) for the operating lever, ref. fig. 6. The switch is connected in series with the motor current and is activated by the operating lever (54.1) to shut off the motor in neutral or free position.

Adjustments

The operating point of the microswitch (33.2) should be set according to fig. 7. The motor should start when the operating lever (54.1) is moved from neutral to either normal forward, fast wind or fast rewind position. Unscrew the three screws A, B, and C ref. fig. 6. Adjust the horizontal position of the delrin bracket (33.5) and the vertical position of the microswitch (33.2) obtaining proper positions for correct operating point.

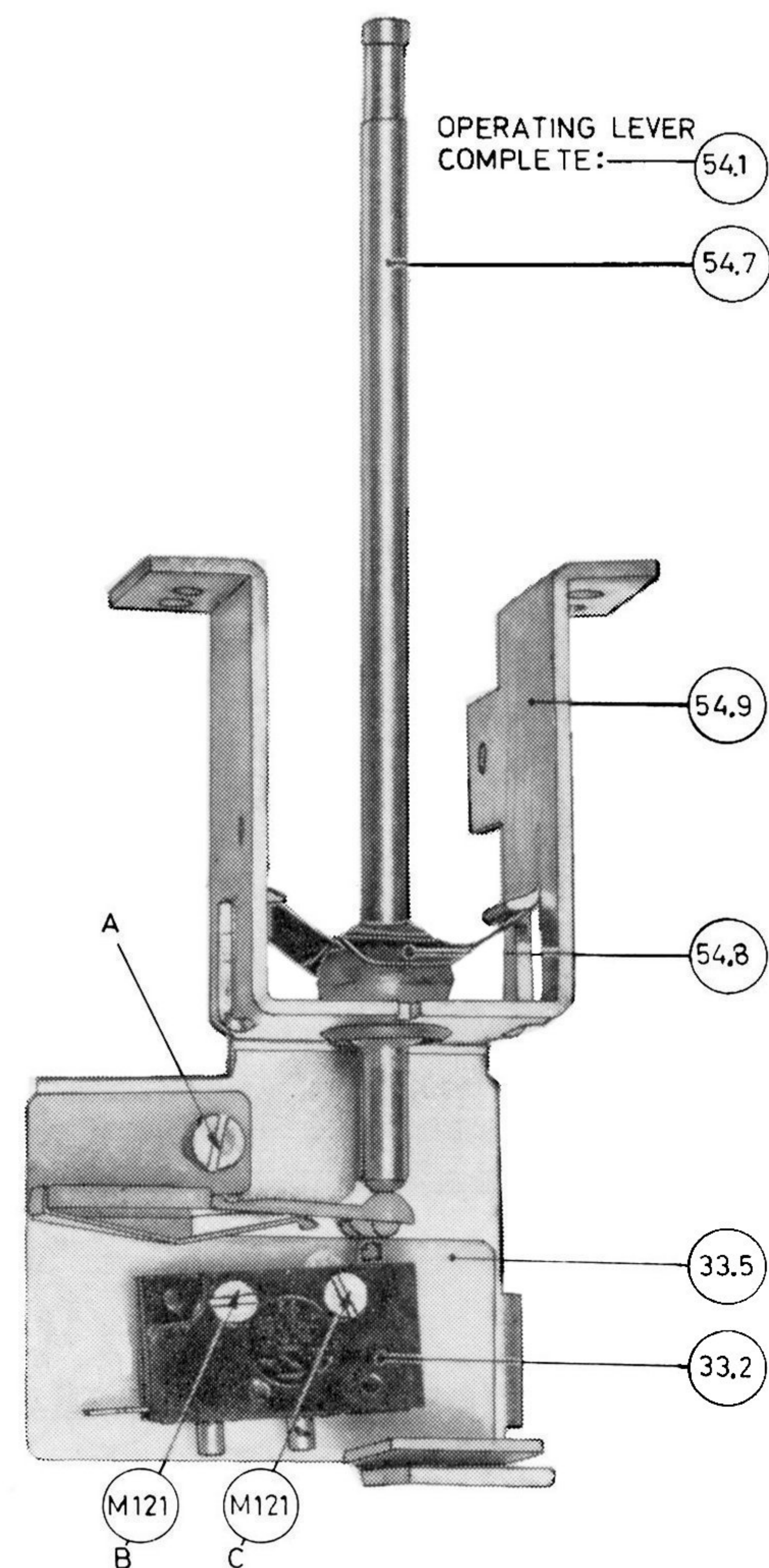

Fig. 6. The operating lever.

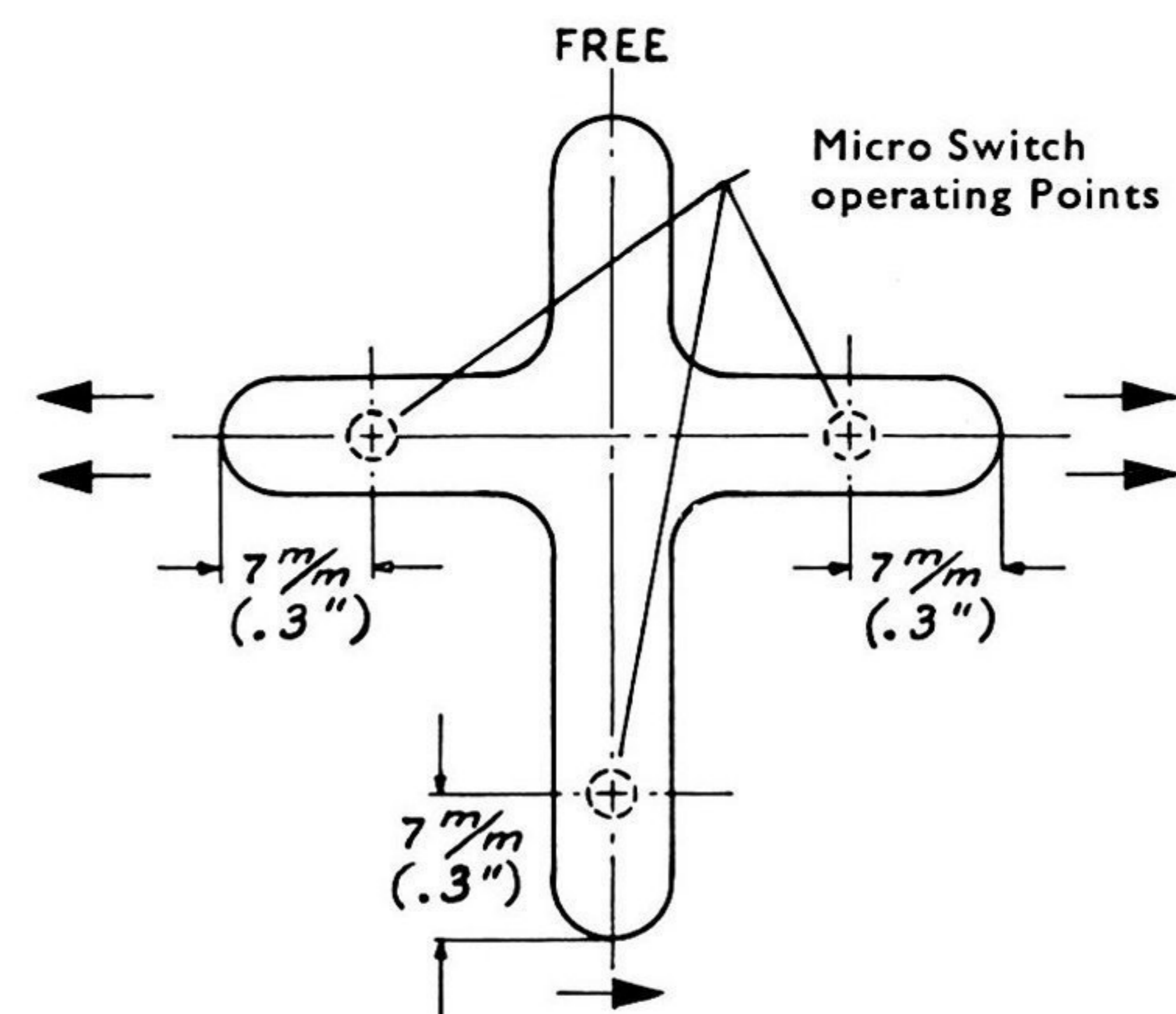

Fig. 7. Adjustment of the operating points for the microswitch.

4.1.2 The eccentric segment

The eccentric segment (59.17) is located underneath the upper mounting plate (71.2), and is connected to the operating lever (54.1). Ref. fig. 8 and 9. The eccentric segment (59.17) moves the pressure wheel assembly (51.3) with the pressure wheel (51.1)

against the capstan (66.2) when the operating lever (54.1) is being set to normal forward drive. The lifting arm (59.18) is linked to the eccentric segment (59.17) and releases the speed transfer wheel (53.1) from contacting the motor pulley (62.1) in all operating modes, except in the normal forward drive position.

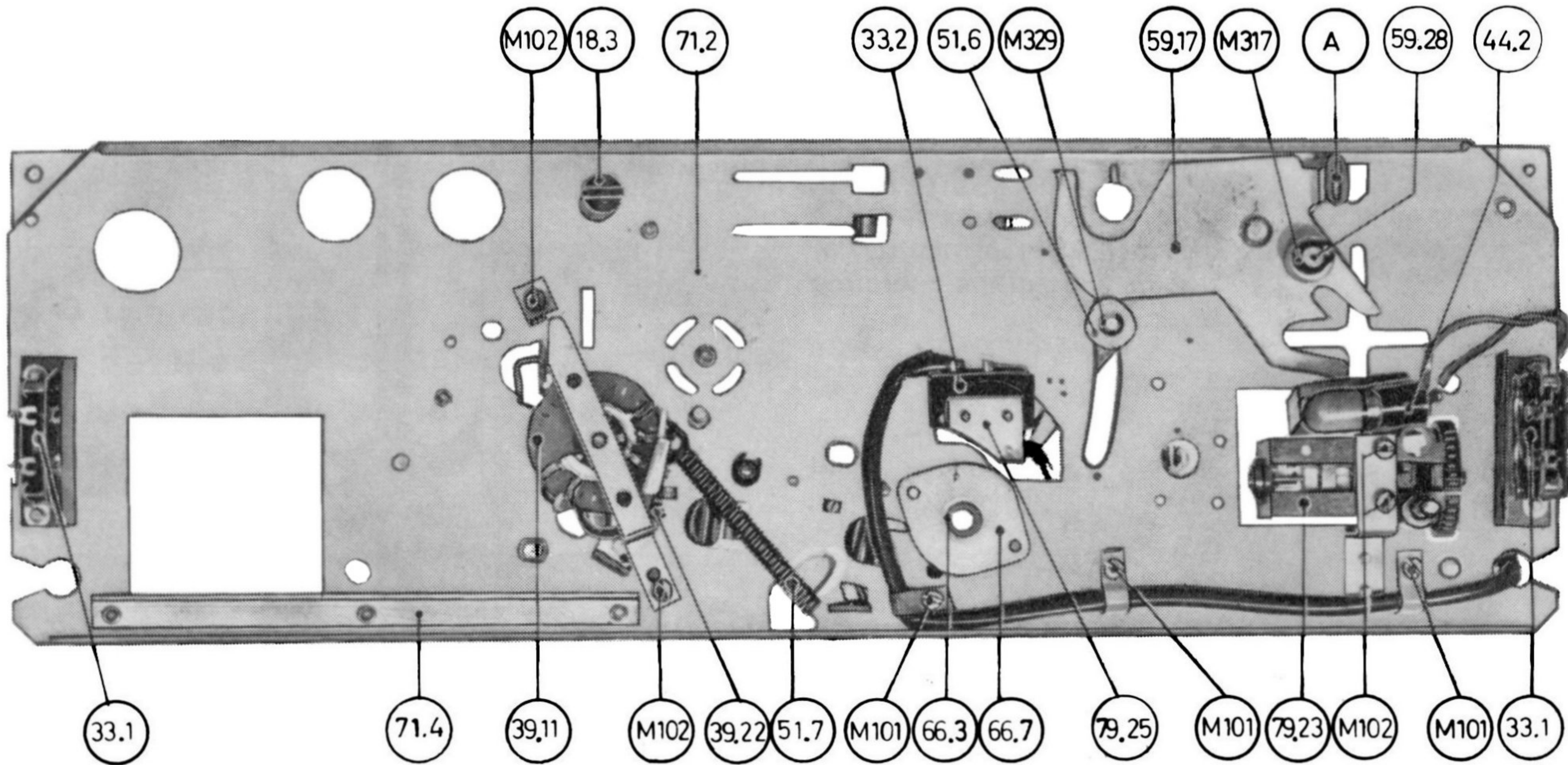

Fig. 8. The upper mounting plate, bottom view.

Adjustments

Adjust the return motion of the pressure wheel assembly (51.3) by bending the lug (A) ref. fig. 8 to

ascertain easy threading of the tape in the slot between the two trim covers (73.1, 73.2). The tape should not stick against the pressure wheel (51.1) during the threading.

4.1.3 The pressure wheel assembly

The pressure wheel assembly (51.3) is guided into operating position by the eccentric segment (59.17) when the operating lever (54.1) is moved to normal forward drive. The pressure wheel (51.1) is mounted under balanced spring tension, with the pressure wheel shaft (51.2) running through two oblong slots in the pressure wheel bracket (51.12). This mounting gives the pressure wheel (51.1) approx. 6 mm (1/4") horizontal springloaded play, on a line perpendicular to the front of the upper mounting plate (71.2). Ref. fig. 9.

Adjustments

The balanced spring tension of the pressure wheel (51.1) is adjusted to obtain uniform pressure of the pressure wheel against the capstan. Loosen screw E, and turn the spring equalization latch (51.11) clockwise or counter clockwise until the tape runs smoothly by the pressure wheel (51.1) in normal forward drive. Make sure that no air-pockets are formed between the tape and the pressure wheel (51.1) and that the tape is completely covered by the rubber surface of the pressure wheel. Ref. fig. 9 and 10.

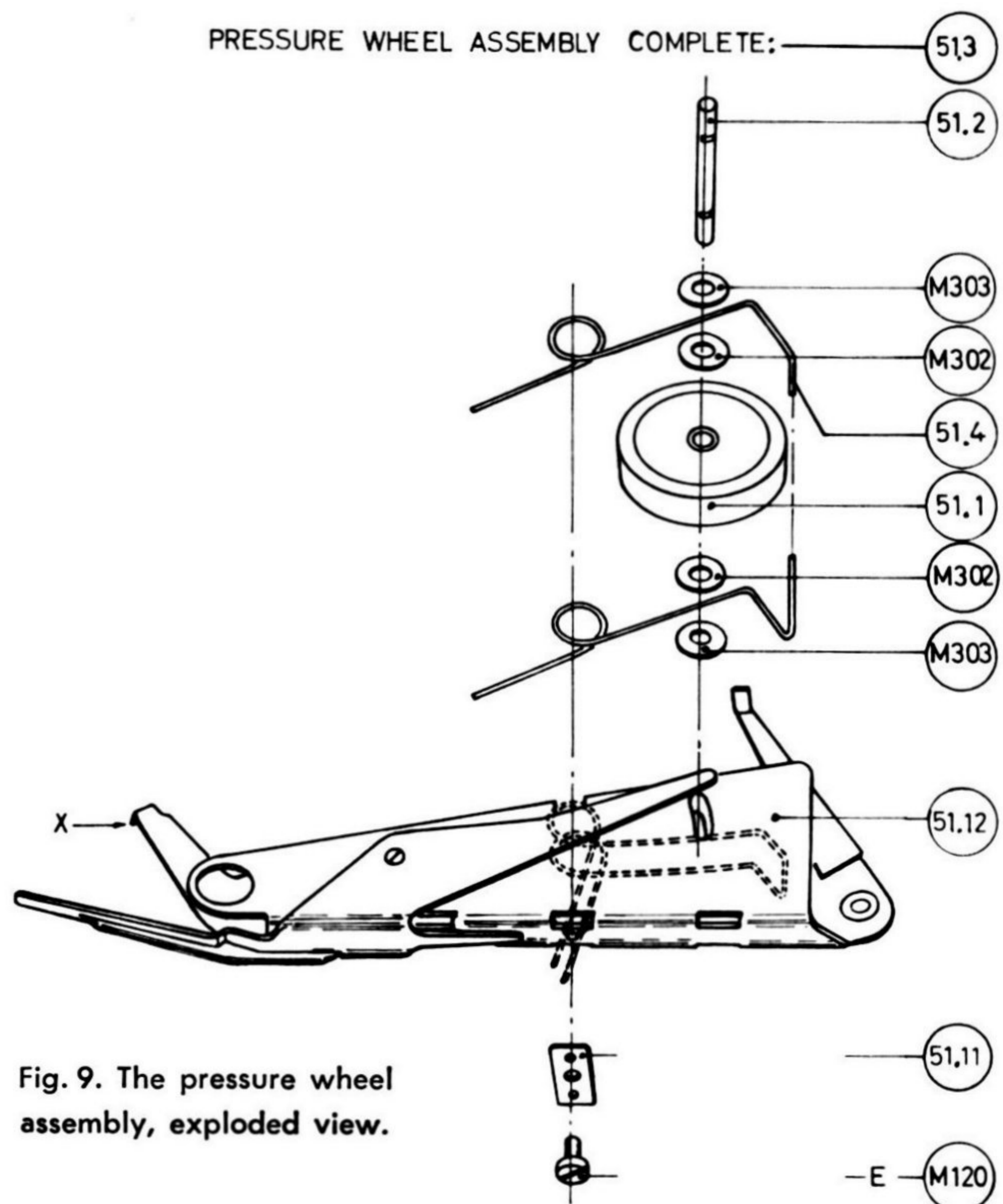

Fig. 9. The pressure wheel assembly, exploded view.

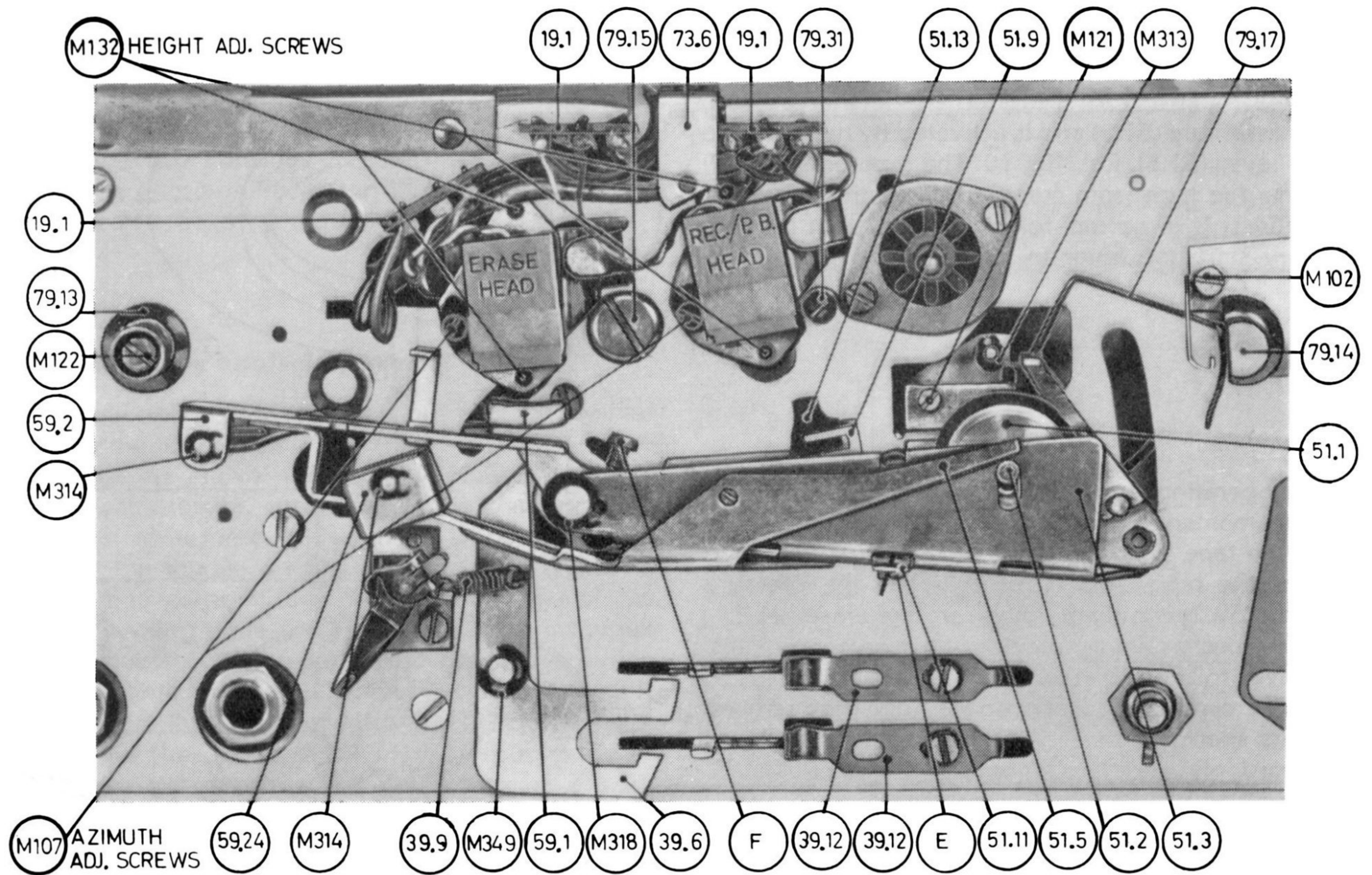

Fig. 10. Mounting of the heads with the pressure wheel assembly.

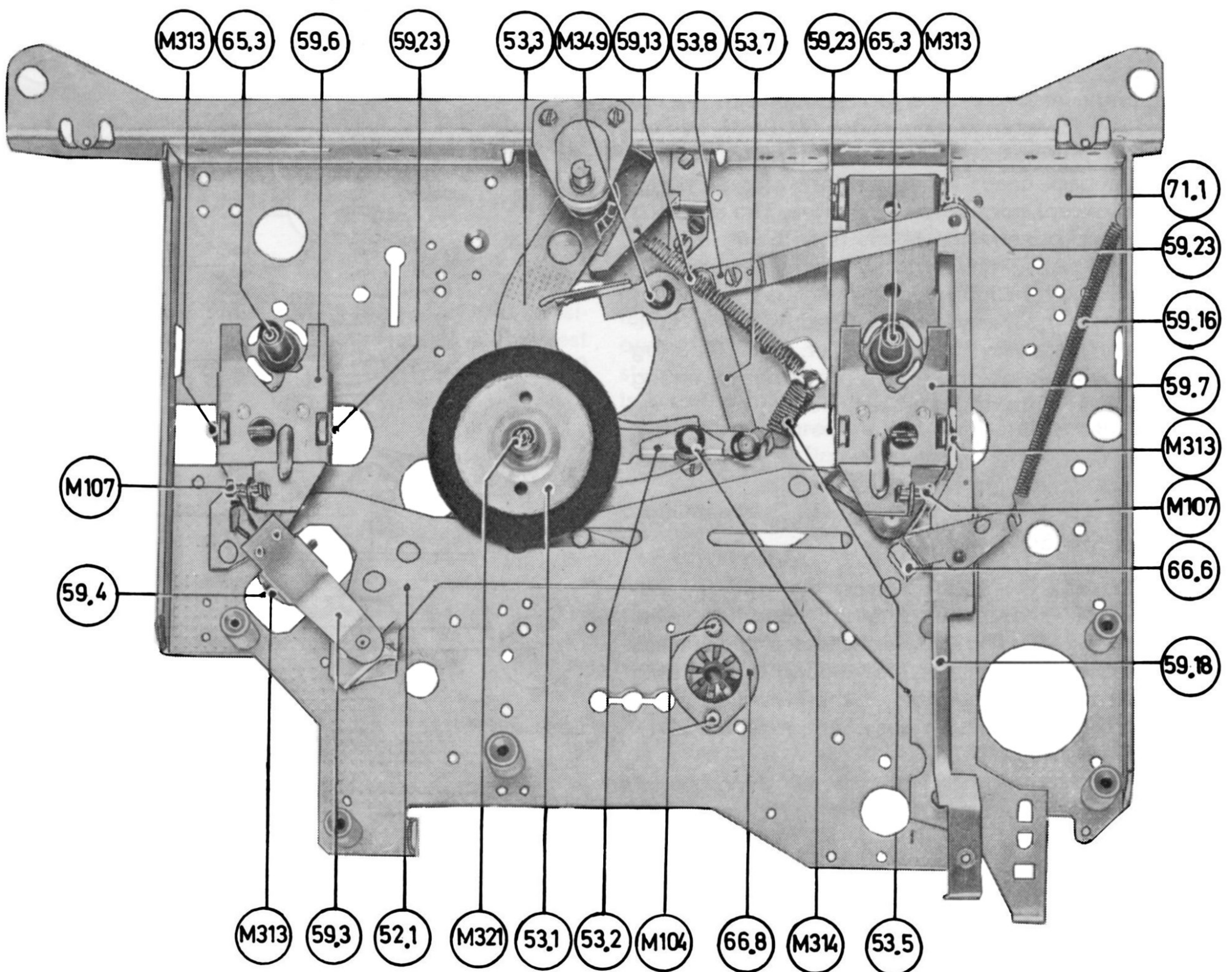

Fig. 11. The lower mounting plate, with the turntables removed.

Note: Ref. fig. 54 for tape recorders with serial No. below 720 000.

4.1.4 The tape brake

The tape brake (51.9) is located inside the pressure wheel assembly (51.3) and is activated by the pressure wheel lever (51.5). Ref. fig. 10. The tape brake (51.9) prevents the tape from creeping when the operating lever (54.1) is in normal forward drive, with the momentary start-stop lever in stop position (right position).

Adjustments

Set the operating lever (54.1) to normal forward drive and the momentary start-stop lever to the stop position, with tape inserted. The tape brake (51.9) should prevent the tape from creeping when the pressure pad arm (59.2) is pulled away from the erase head. Start the mechanism by moving the momentary start-stop lever to the left position. The tape brake (51.9) should be completely disengaged. Adjust the screw F until the spacing between the tape brake (51.9) and the record/playback head is approx. 2 mm (.08").

4.1.5 The mechanical connection for the muting switch

The muting switch (39.11) is located between the upper and the lower mounting plates (71.2, 71.1). Ref. fig. 8. The muting switch (39.11) shortcircuits both record playback heads in all positions of the operating lever, except normal forward drive. The switch is introduced to prevent the heads from being magnetized by the transient electrical shocks which will appear when the function selector switch is operated. The pressure wheel bracket (51.12) activates the muting switch (39.11) by the lug X. Ref. fig. 9. The lug enters through an oblong slot in the upper mounting plate (71.2) in front of the erase head.

4.1.6 The trip bar

The trip bar (52.1) is located across the lower mounting plate (71.1), and linked to the operating lever (54.1). Ref. fig. 11. The trip bar activates the clutches underneath both turntables (65.1, 65.2) by a sliding motion. The vertical position of the two clutches is determined by the raised areas of the trip bar (52.1).

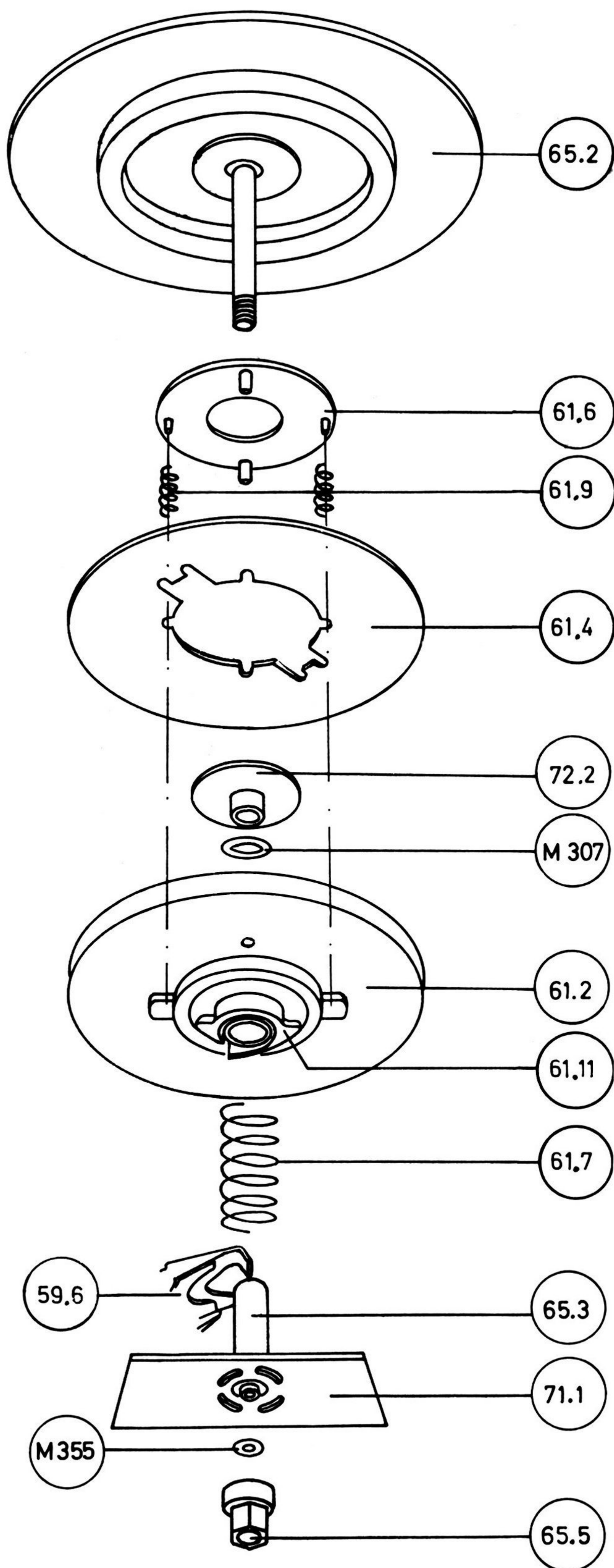

Fig. 12. The supply turntable assembly, exploded view.

Note: Ref. fig. 55 for tape recorders with serial No. below 719 000.

4.2 THE TURNTABLE ASSEMBLIES

The design of the turntable assemblies is shown in fig. 12 and 15. The turntable assemblies are built up around the two housings for the turntable bearings (65.3). The housings for the turntable bearings (65.3) are riveted to the lower mounting plate (71.1).

4.2.1 The supply turntable assembly

The supply turntable assembly is put together by first inserting the helical compression spring (61.7) and the pulley disc (61.2) over the housing (65.3). Make sure that the compression spring (61.7) fits into the cylindrical groove in the cartridge (61.11). The two delrin lugs and the tongue on the cartridge (61.11) should lie on a line perpendicular to the front edge of the upper mounting plate (71.2), with the delrin tongue pointing towards the front. Press down the pulley disc (61.2) until the delrin lugs on the cartridge (61.11) have passed through the notch in the clutch lever (59.6). Turn the cartridge (61.11) 90° counter clockwise. Make sure that the two delrin lugs have been locked in position by the claws on the clutch lever (59.6), and that the tongue on the cartridge (61.11) fits into the groove in the clutch lever (59.6). Ref. fig. 12 and 13.

Insert the flange for the turntable housing (72.2) by pressing it into the upper end of the housing (65.3). Place the mylar sheet (61.4) on the top of the pulley disc (61.2), and insert the two springs (61.9) in the wells. Attach the tape tight disc (61.6) with the short pins inside the two springs (61.9) and insert the turntable (65.2). Ref. fig. 14.

Move the operating lever (54.1) to the fast wind position. This will allow the supply turntable (65.2) to rest on the flange (72.2). Insert one teflon washer (M355)

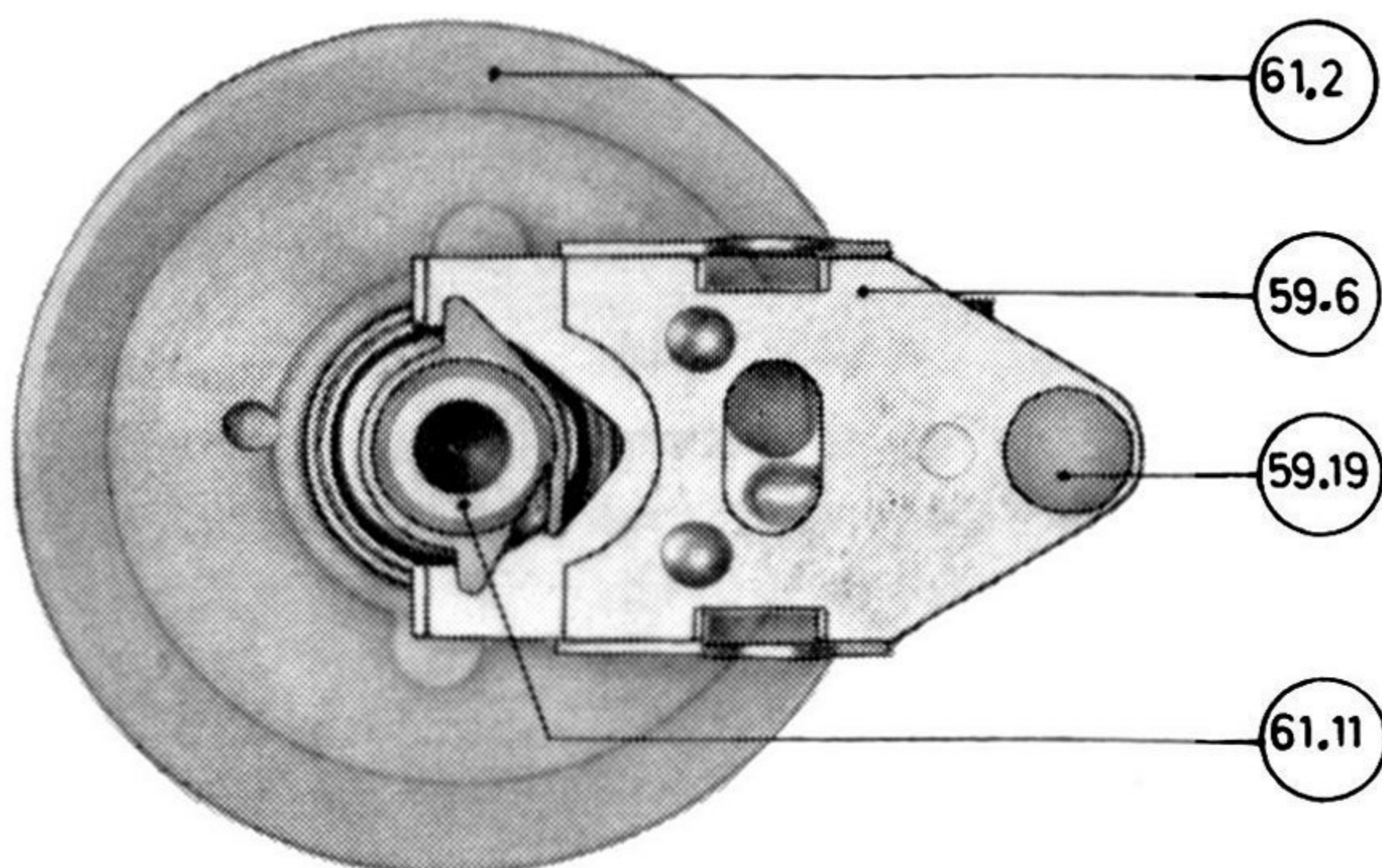

Fig. 13. The supply pulley disc with the clutch lever.

on the turntable shaft, under the lower mounting plate (71.1), before the delrin nut (65.5) is attached. Ascertain an axial play in the turntable shaft of approx. 0.1 mm (.04").

Note: The supply turntable assembly has been modified from ser. No. 719 001. Ref. fig. 55 and 57 for tape recorders with ser. No. below 719 000.

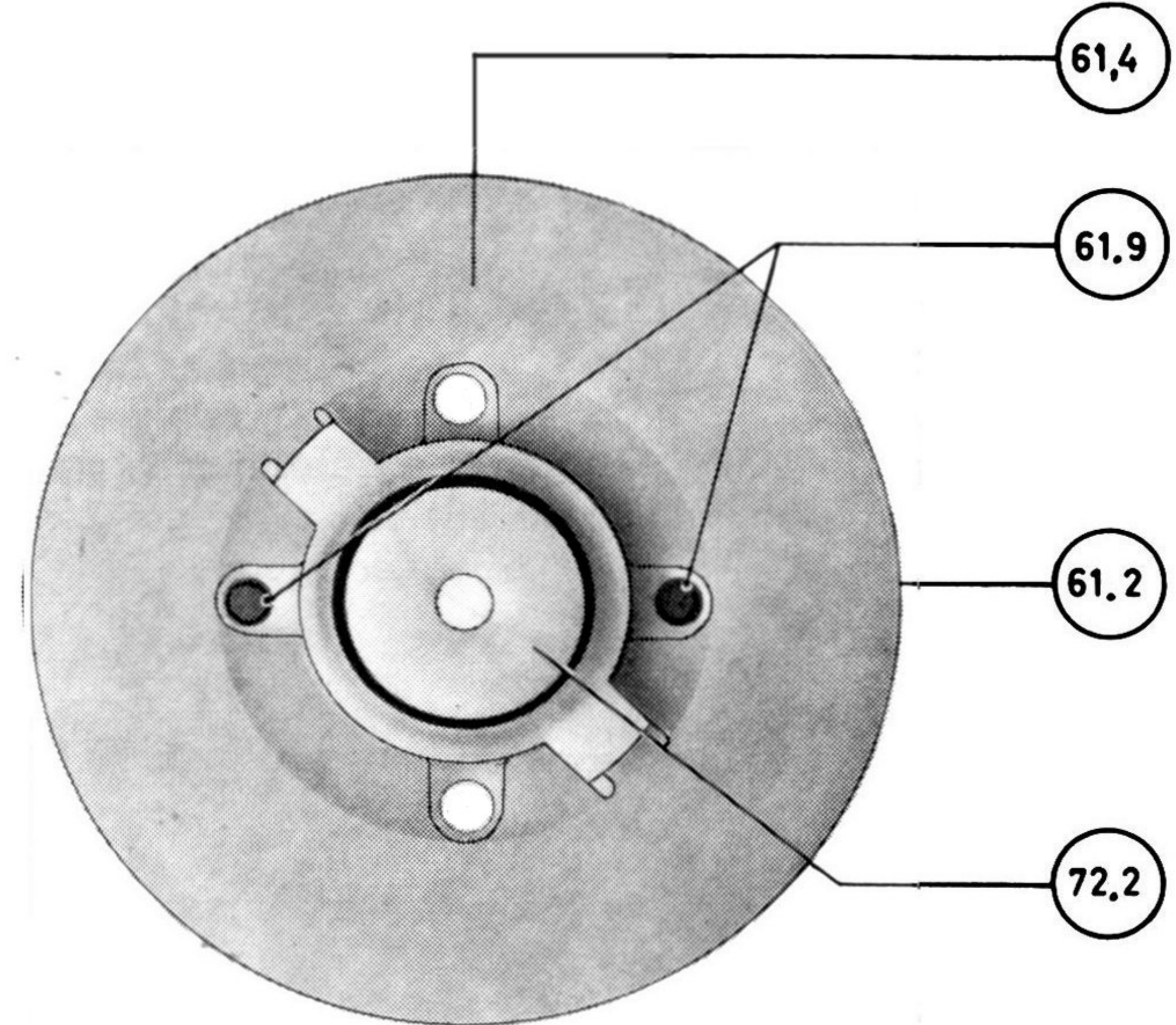

Fig. 14. The supply pulley disc with the mylar sheet.

Note: Ref. fig. 57 for tape recorders with serial No. below 719 000.

4.2.2 The tape tight tension

A slight permanent clockwise torque of the supply turntable (65.2) has been introduced to prevent a tape loop from being formed between the supply turntable (65.2) and the trim covers (73.1, 73.2) when the operating lever is in normal forward drive, and the start-stop lever is operated. The tape tight disc (61.6) is a spring loaded friction disc that presses against a round piece of green felt underneath the supply turntable (65.2), ref. fig. 12.

Adjustments

The adjustment is made by stretching or cutting the two springs (61.9). The torque should be just sufficient to take up the loop formed when the operating lever is in normal forward drive, and the tape recorder stopped by the momentary start-stop lever. The tape recorder should be loaded with a full 7" tape reel on the supply turntable (65.2).

Note: Do not increase this torque unnecessarily, as excessive torque might introduce wow and flutter.

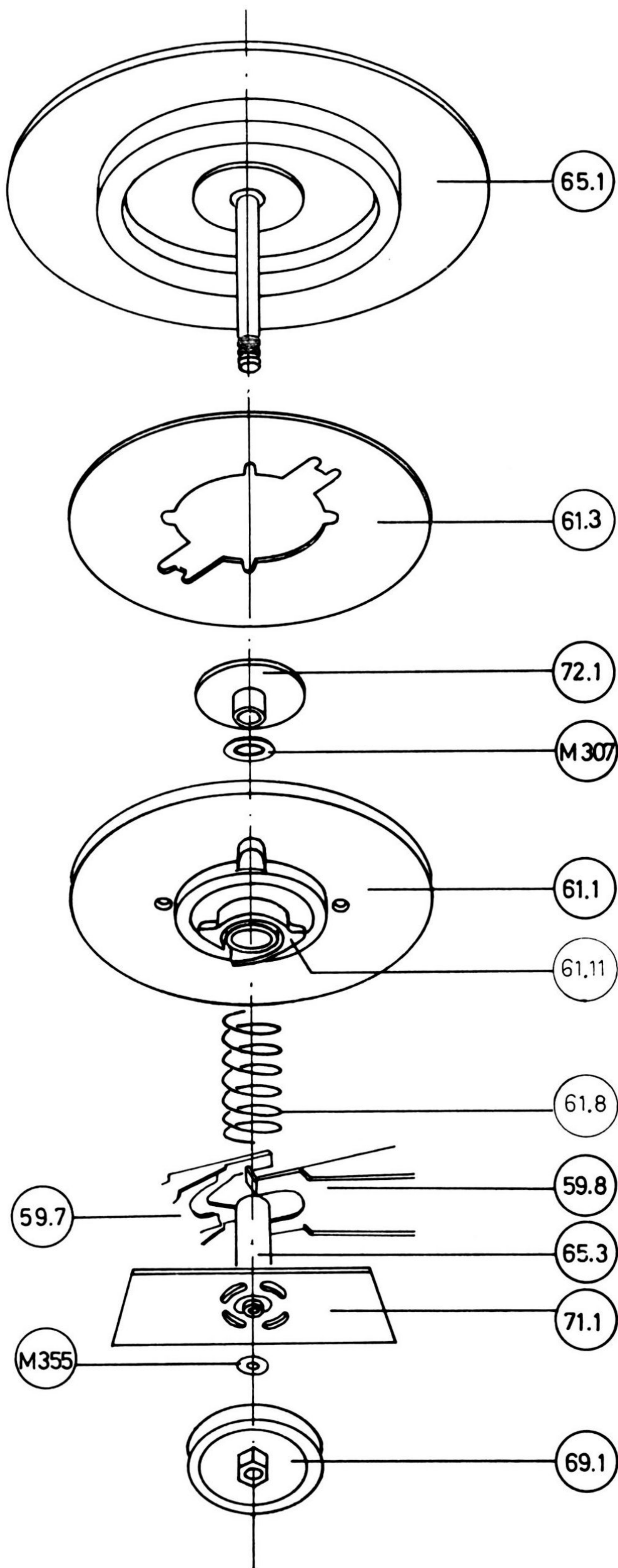

Fig. 15. The take-up turntable assembly, exploded view.

Note: Ref. fig. 56 for tape records with serial No. below 719 000.

4.2.3 The take-up turntable assembly

The take-up turntable is put together by first inserting the helical compression spring (61.8) and the pulley disc (61.1) over the housing (65.3). Make sure the compression spring (61.8) fits into the cylindrical groove in the cartridge (61.11). The two delrin lugs and the tongue on the cartridge (61.11), should lie on a line perpendicular to the front edge of the upper mounting plate (71.2), with the delrin tongue pointing at the rear edge of the lower mounting plate (71.1). Press down the pulley disc (61.1) until the delrin lugs on the cartridge (61.11) have passed through the notch in the upper clutch lever (59.7). Press the lower clutch lever (59.8) all the way down by using a screw driver. The space between the two clutch levers (59.7, 59.8) will now be approx. 6 mm (1/4"). Turn the cartridge (61.11) 90° clockwise, and make sure that the two delrin lugs have been locked in position by the claws on the lower clutch lever (59.8). Ref. fig. 15 and 16.

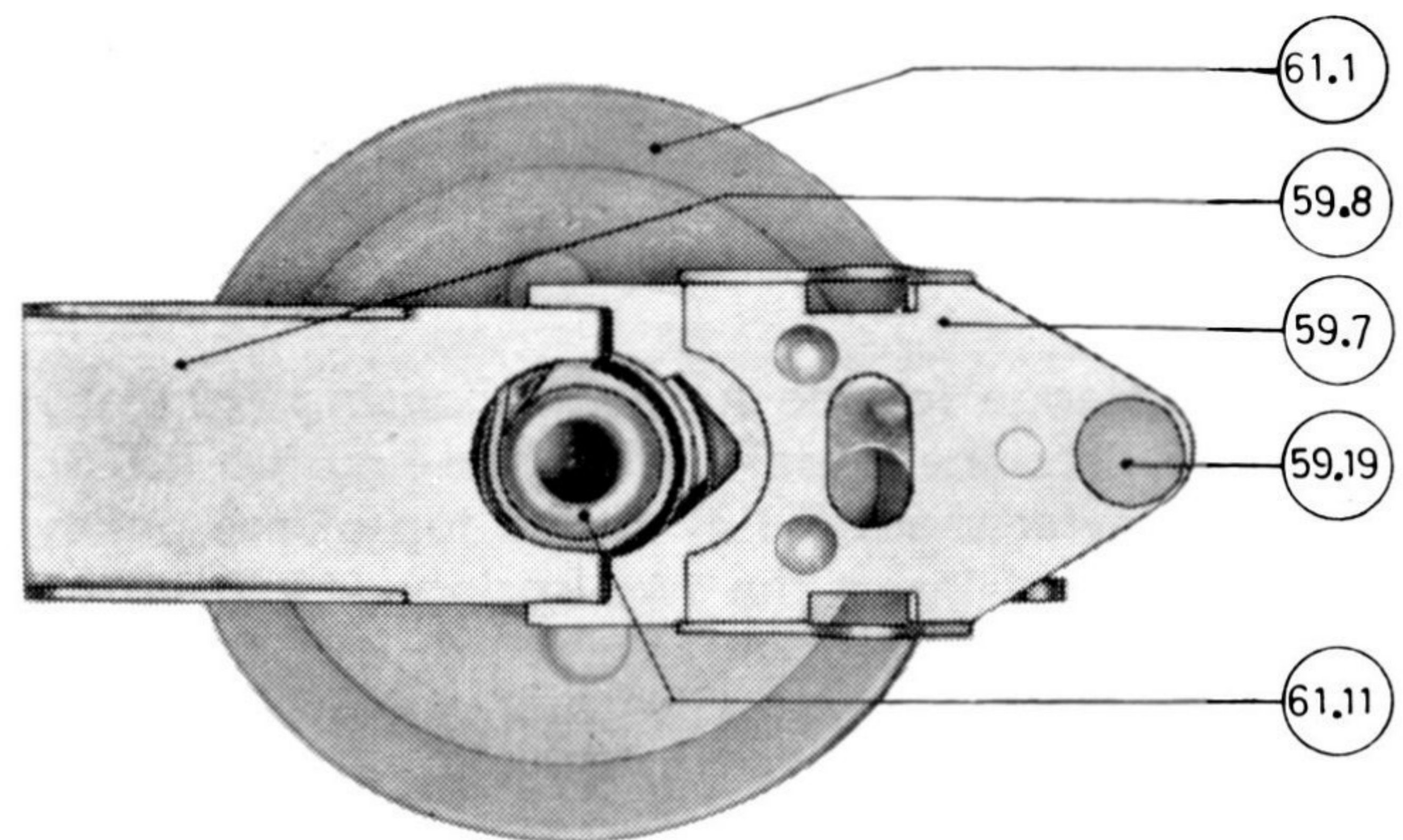

Fig. 16. The take-up pulley disc with the clutch levers.

Insert the flange for the turntable housing (72.1) by pressing it into the upper end of the housing (65.3) and insert the turntable (65.1).

Move the operating lever (54.1) to the fast rewind position. This will allow the take-up turntable (65.1) to rest on the flange (72.1). Insert one teflon washer (M355) on the turntable shaft, under the lower mounting plate (71.1) before the pulley (69.1) is attached. Ascertain an axial play of the turntable shaft of approx. 0.1 mm (.04").

4.2.4 Horizontal and vertical alignments of the turntables

Use the special tools 1, 2, and 3 for these alignments. Ref. fig. 59.

Horizontal alignments

The horizontal position of the two turntables (65.1, 65.2) parallel to the lower mounting plate (71.1) is checked by placing the special tool No. 1 across both turntables as shown in fig. 17. There should be no spacing between the ruler (tool No. 1) and the turntables.

Necessary adjustments are made by bedding the turntable housing in correct position. Use the special tool No. 3, as shown in fig. 18.

The horizontal position of both turntables (65.1, 65.2), parallel to a line perpendicular to the front edge of the upper mounting plate (71.2) is checked by using the special tool No. 2.

The edge of the special tool No. 2 should run exactly

into the tape groove in the guide (79.13, 79.14), when the operating lever (54.1) is in the neutral position. Ref. fig. 19.

Necessary adjustments are made by bending the turntable housing (65.3) in correct position. Use special tool No. 3, as shown in fig. 18.

Vertical alignments

The horizontal position of the turntables must be set before the vertical alignment is made.

The vertical position of the turntables is checked with the tape threaded on the recorder. The tape should not touch the edges of the plastic reels in any mode of operation.

The turntables are raised or lowered, if necessary, by adding or subtracting turbax washers (M306-7) between the flange for the turntable housing (72.1, 72.2) and the turntable housing (65.3). Ref. fig. 12 and 15. A final check of the horizontal position of the turntables should be made.

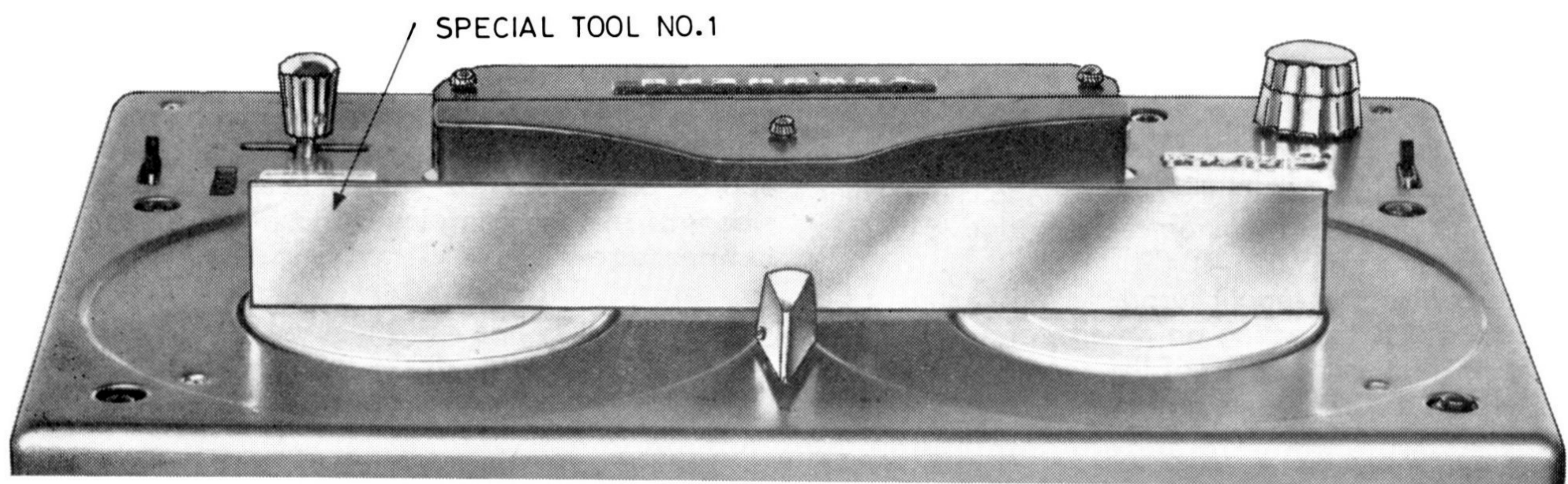

Fig. 17. Control of the horizontal position of the turntables with tool No. 1.

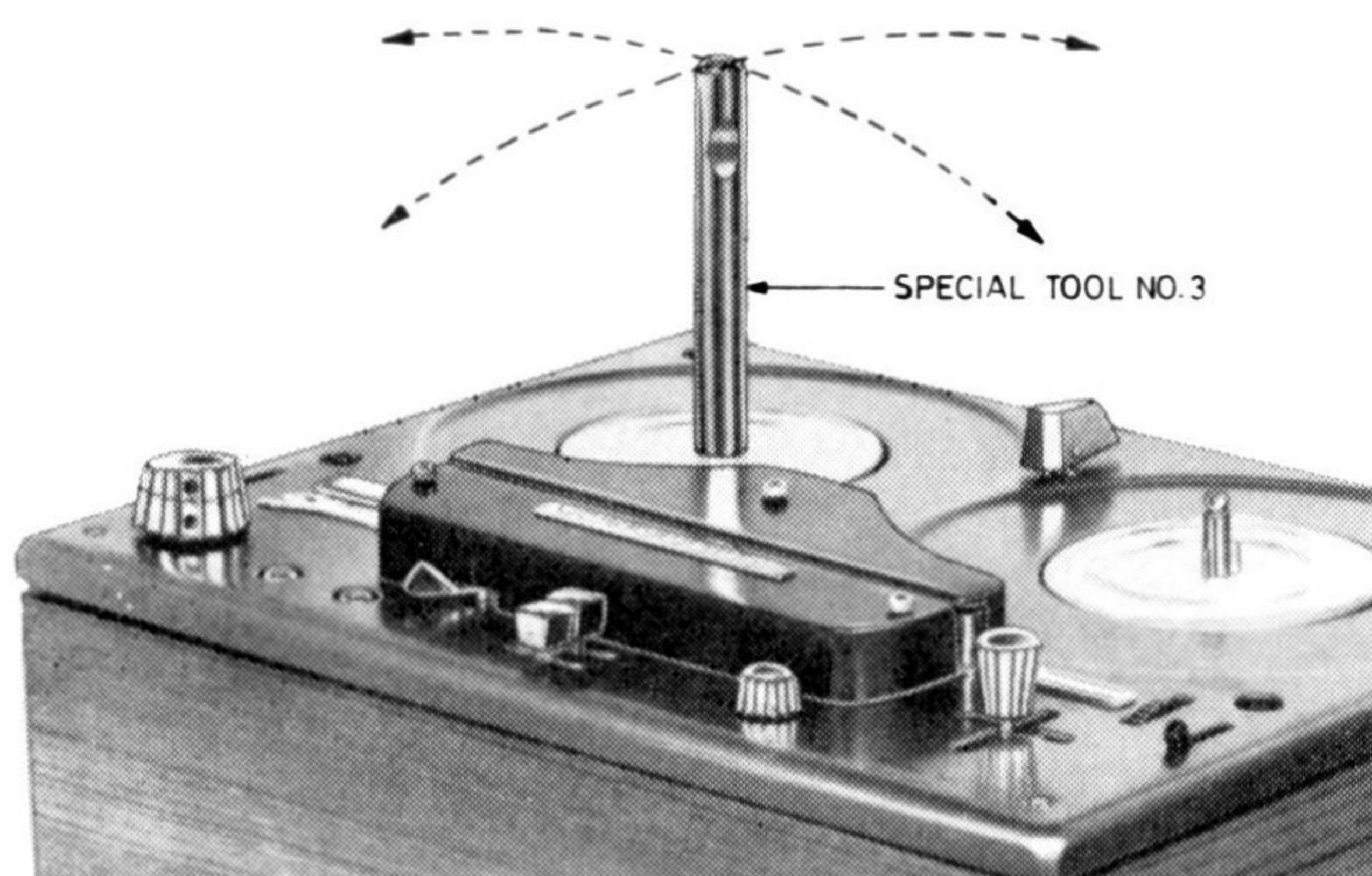

Fig. 18. Alignment of the horizontal position of the turntables with tool No. 3.



Fig. 19. Control of the horizontal position of the turntables with tool No. 2.

4.3 CLUTCH ALIGNMENTS

4.3.1 General

The motor will always run and drive both pulley discs (61.1, 61.2) when the operating lever (54.1) is set to either normal forward drive, fast wind, or fast rewind position. The two pulley discs will run in the opposite directions caused by the cross threading of the rubber drive belt (62.2). Ref. fig. 5.

The torque of the turntables (65.1, 65.2) is obtained by the friction between the pulley discs (61.1, 61.2) and the feltrings glued to the turntables (65.1, 65.2). The friction between the pulley discs and the turntables is determined by the position of the clutches mounted under each pulley disc. The clutches are operated by the trip bar (52.1), which is connected to the operating lever (54.1).

4.3.2 Fast rewind

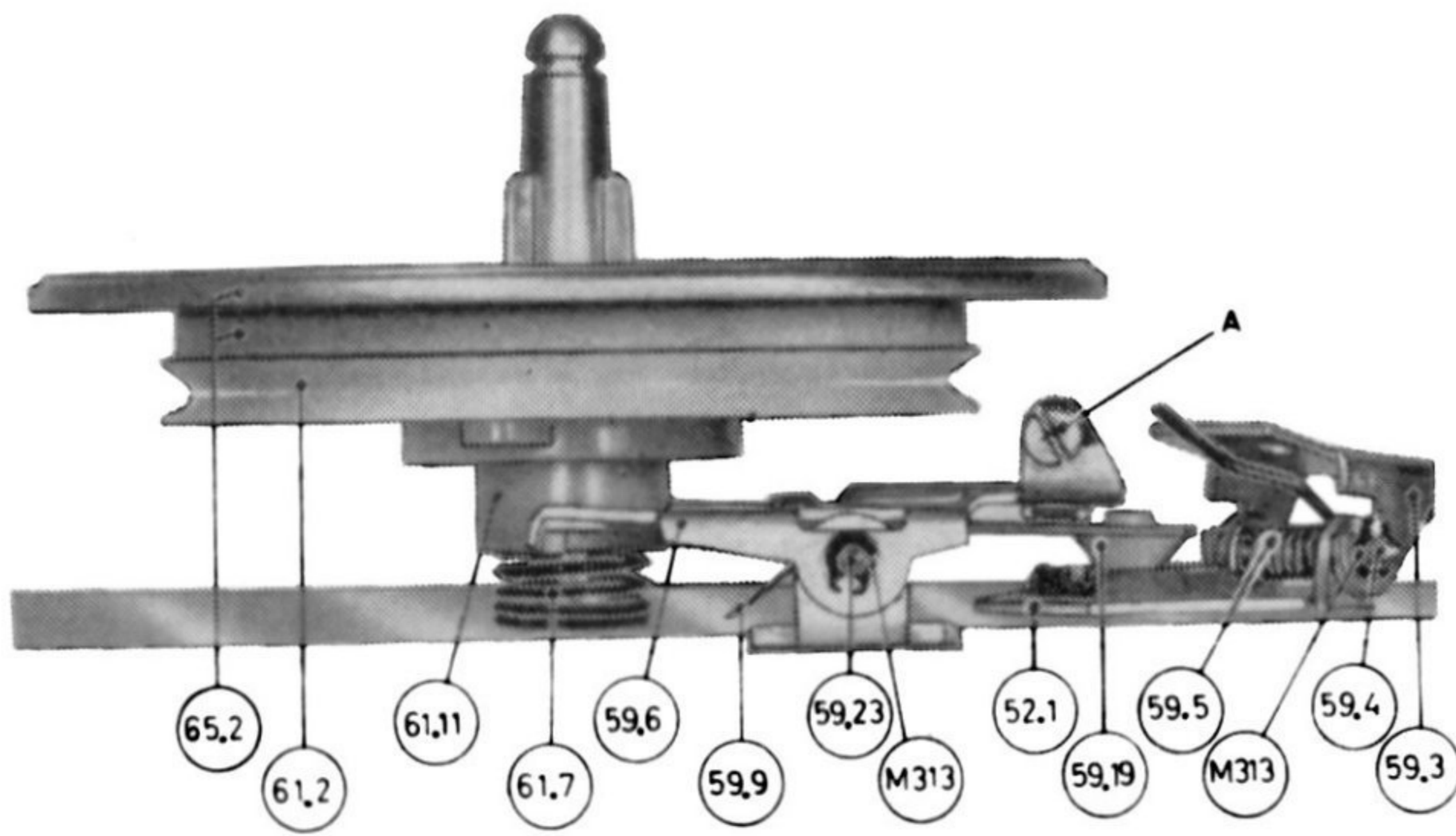

Fig. 20.

The supply turntable

The supply turntable (65.2) has maximum obtainable friction with the pulley disc (61.2) in this position. Ref. fig. 20.

The pulley disc (61.2) is pressed against the turntable (65.2) by the entire tension of the compression spring (61.7).

The trip bar (52.1) has moved, and the delrin button (59.19) on the clutch lever (59.6) is at the lowest position. The two delrin lugs on the cartridge (61.11) and the clutch lever (59.6) are disengaged.

Adjustments

Adjust the height of the clutch lever (59.6) by the screw (A) until the clearance between the clutch lever (59.6) and the delrin lugs on the cartridge (61.11) is approx. 0.5–1 mm (.02"–.04").

The torque of the supply turntable (65.2) should be min. 75 g (2¾ oz) acting on an arm of 8 cm (3½"). Recheck all other positions of the operating lever and finally seal the adjustment screw A.

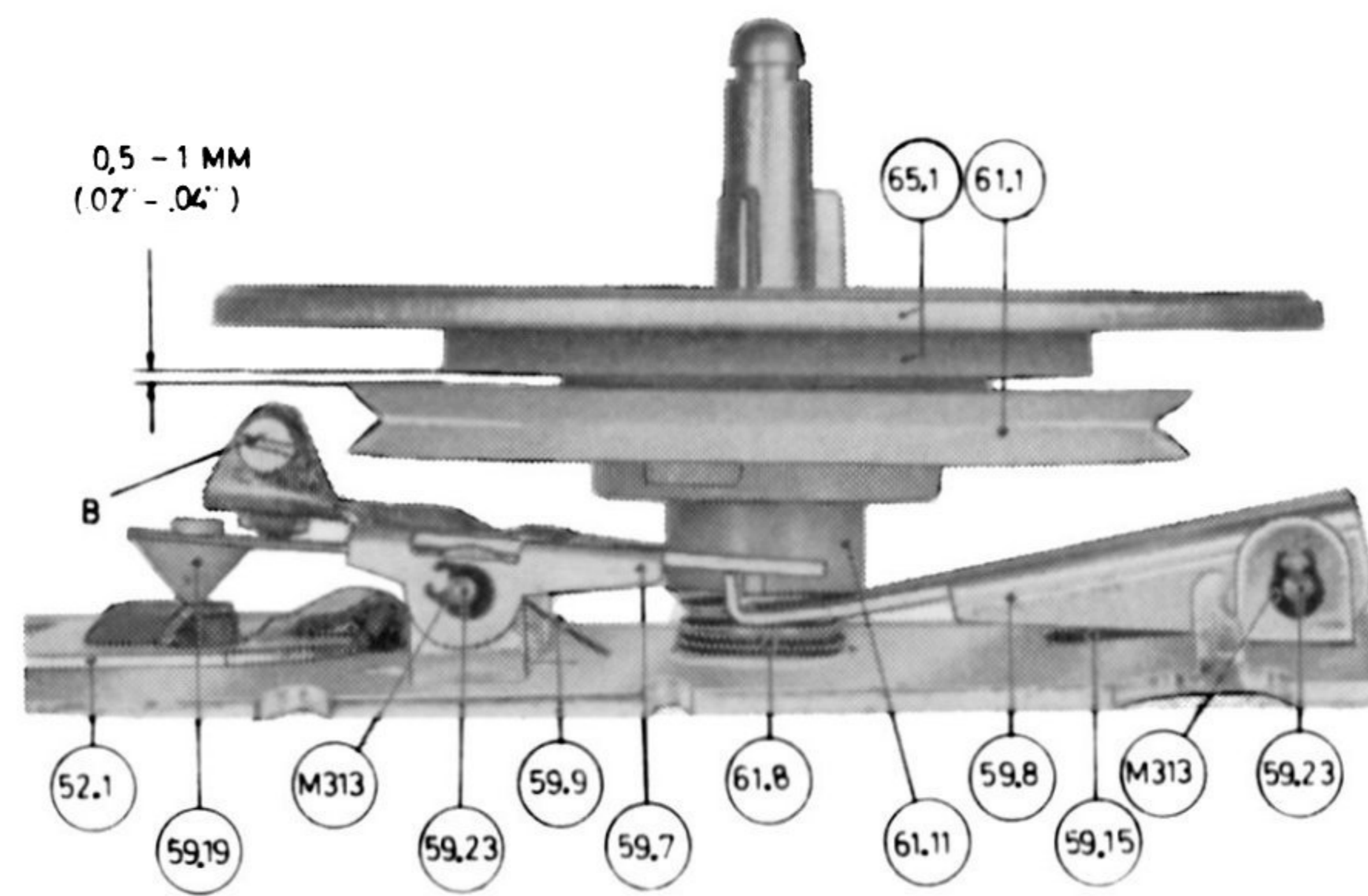

Fig. 21.

The take-up turntable

The take-up turntable (65.1) is completely disengaged from the pulley disc (61.1) and free-running in this position. Ref. fig. 21.

The trip bar (52.1) has moved, and the delrin button (59.19) on the upper clutch lever (59.7) is at the highest position, pressing down both the lower clutch lever (59.8) and the two delrin lugs on the cartridge (61.11).

Adjustments

Adjust the height of the upper clutch lever (59.7) by the screw (B) until the clearance between the pulley disc (61.1) and the feltring on the turntable (65.1) is approx. 0.5–1 mm (.02"–.04"). Recheck all other positions of the operating lever and finally seal the adjustment screw B.

4.3.3 Fast wind

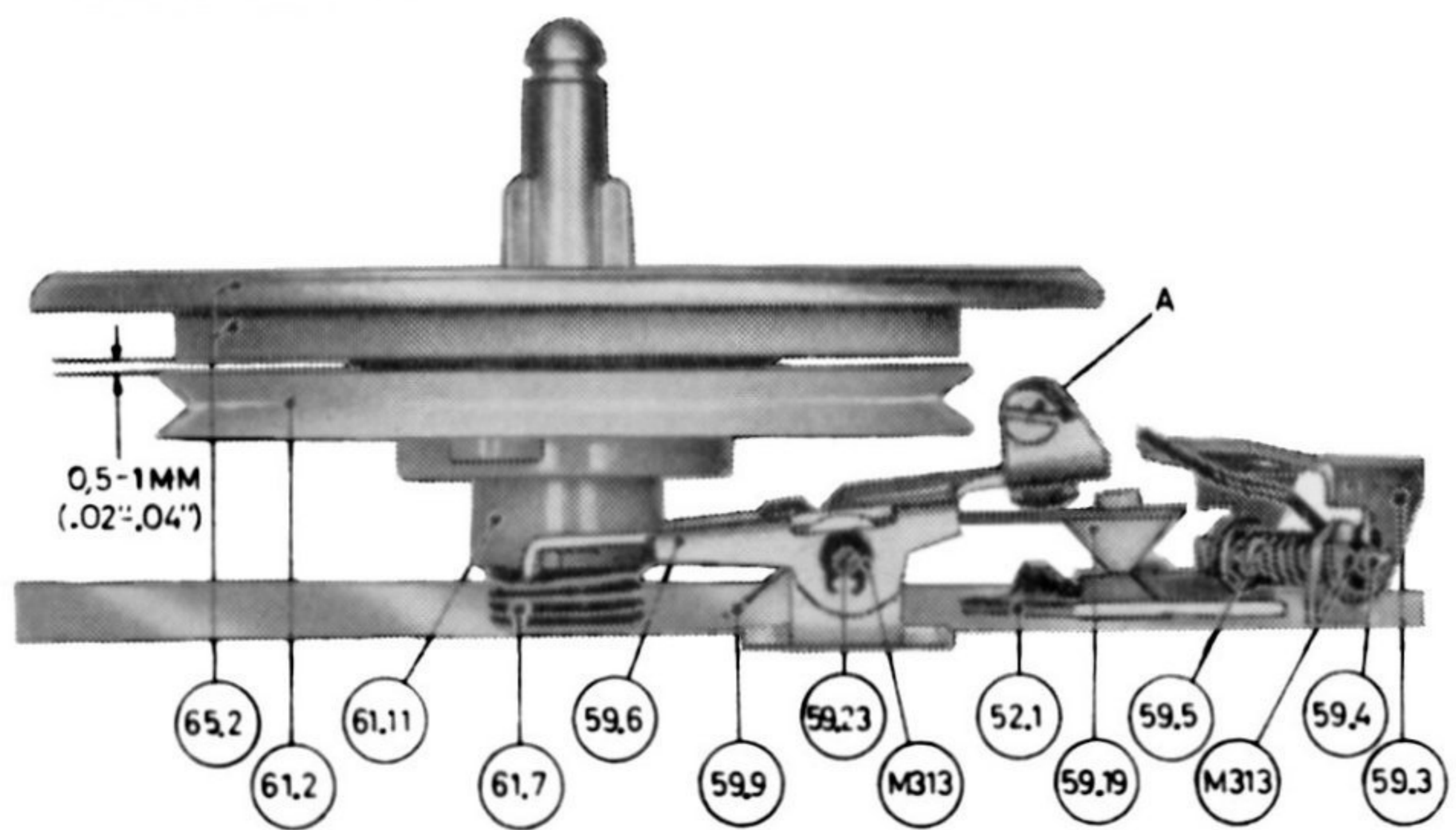

Fig. 22.

The supply turntable

The supply turntable (65.2) is completely disengaged from the pulley disc (61.2) and free-running in this position. Ref. fig. 22.

The trip bar (52.1) has moved, and the delrin button (59.19) on the clutch lever (59.6) is at the highest position, pressing down the two delrin lugs on the cartridge (61.11).

Adjustments

Adjust the height of the clutch lever (59.6) by the screw (A) until the clearance between the pulley disc (61.2) and the feltring on the turntable (65.2) is approx. 0.5–1 mm (.02"–.04"). Recheck all other positions of the operating lever and finally seal the adjustment screw A.

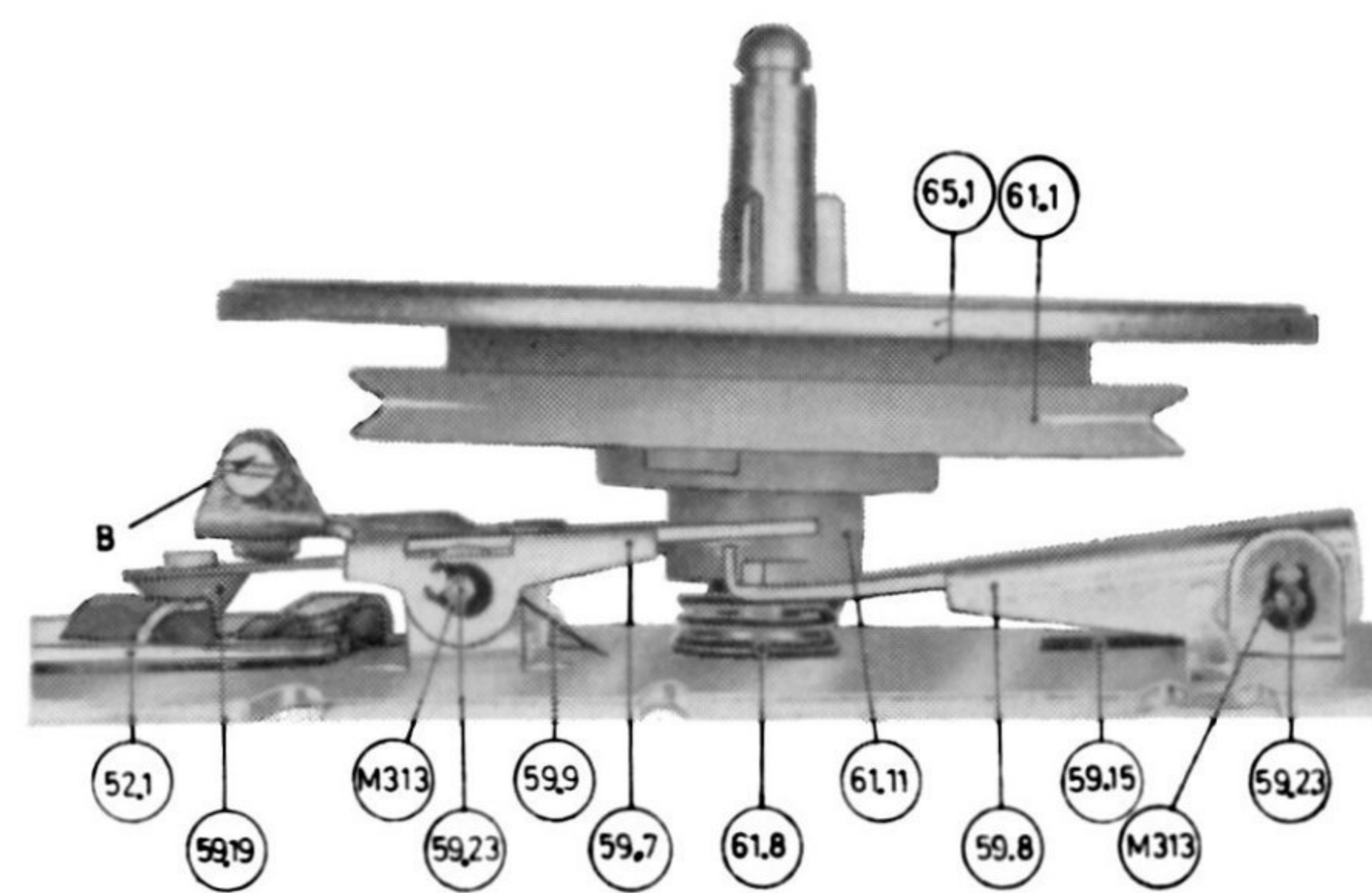

Fig. 23.

The take-up turntable

The take-up turntable (65.1) has maximum obtainable friction with the pulley disc (61.1) in this position. The springloaded lower clutch lever (59.8) is pressing the delrin lugs on the cartridge (61.11) upwards in addition to the entire tension of the compression spring (61.8). Ref. fig. 23.

The trip bar (52.1) has moved, and the delrin button (59.19) on the upper clutch lever (59.7) is at the lowest position, disengaging the lower clutch lever (59.8) and the two delrin lugs on the cartridge (61.11).

Adjustments

Adjust the height of the upper clutch lever (59.7) by the screw (B) until the clearance between the upper and the lower clutch levers (59.7, 59.8) is approx. 0.5 mm (.02").

The torque of the take-up turntable (65.1) should be min. 65 g (2¼ oz) acting on an arm of 8 cm (3½"). Recheck all other positions of the operating lever and finally seal the adjustment screw B.

4.3.4 Normal forward drive

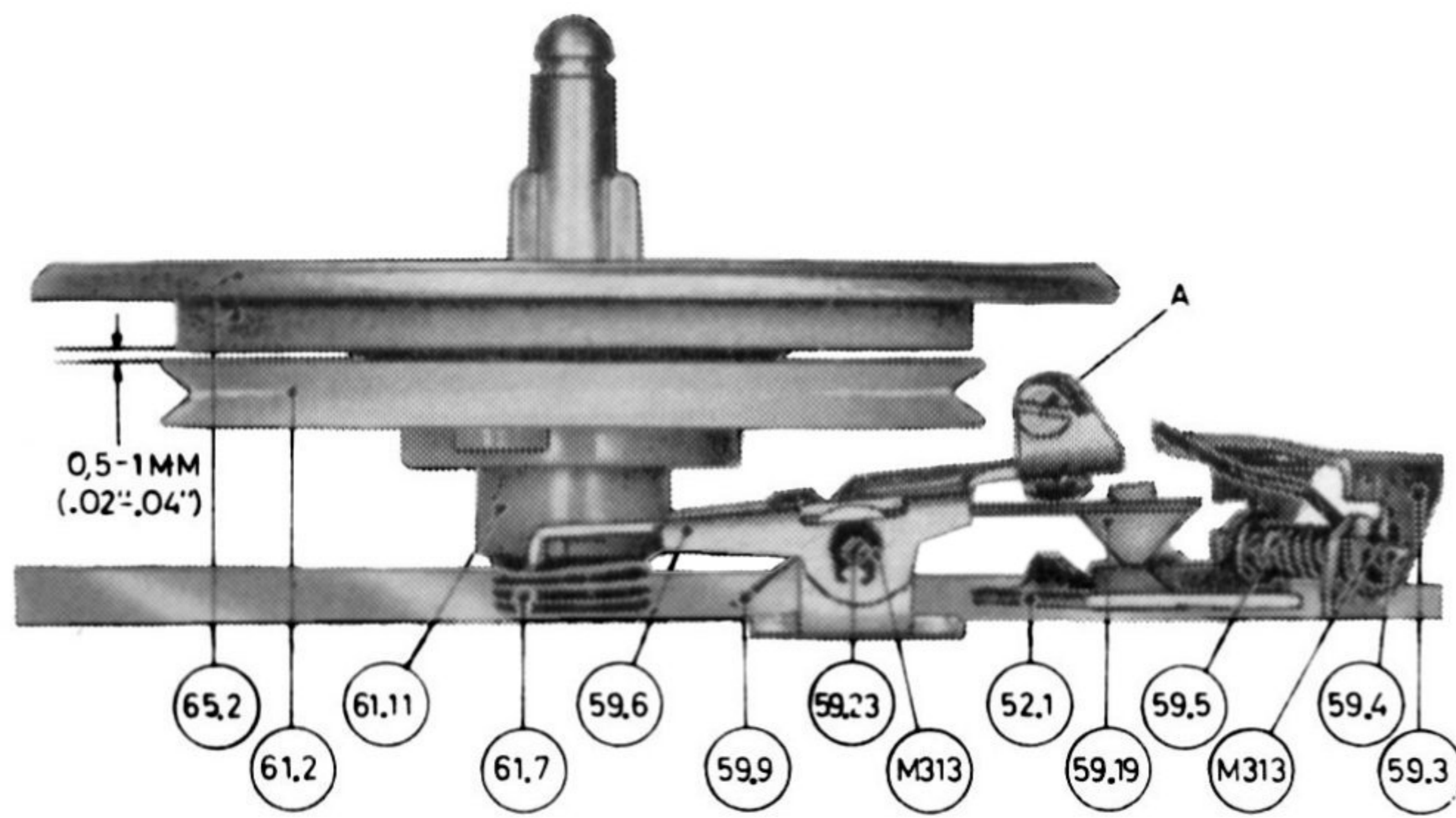

Fig. 24.

The supply turntable

The supply turntable (65.2) is completely disengaged from the pulley disc (61.2) and free-running in this position. Ref. fig. 24.

The trip bar (52.1) has moved, and the delrin button (59.19) on the clutch lever (59.6) is at the highest position, pressing down the two delrin lugs on the cartridge (61.11).

Adjustments

Adjust the height of the clutch lever (59.6) by the screw (A) until the clearance between the pulley disc (61.2) and the feltring on the turntable (65.2) is approx. 0.5–1 mm (.02"–.04"). Recheck all other positions of the operating lever and finally seal the adjustment screw A.

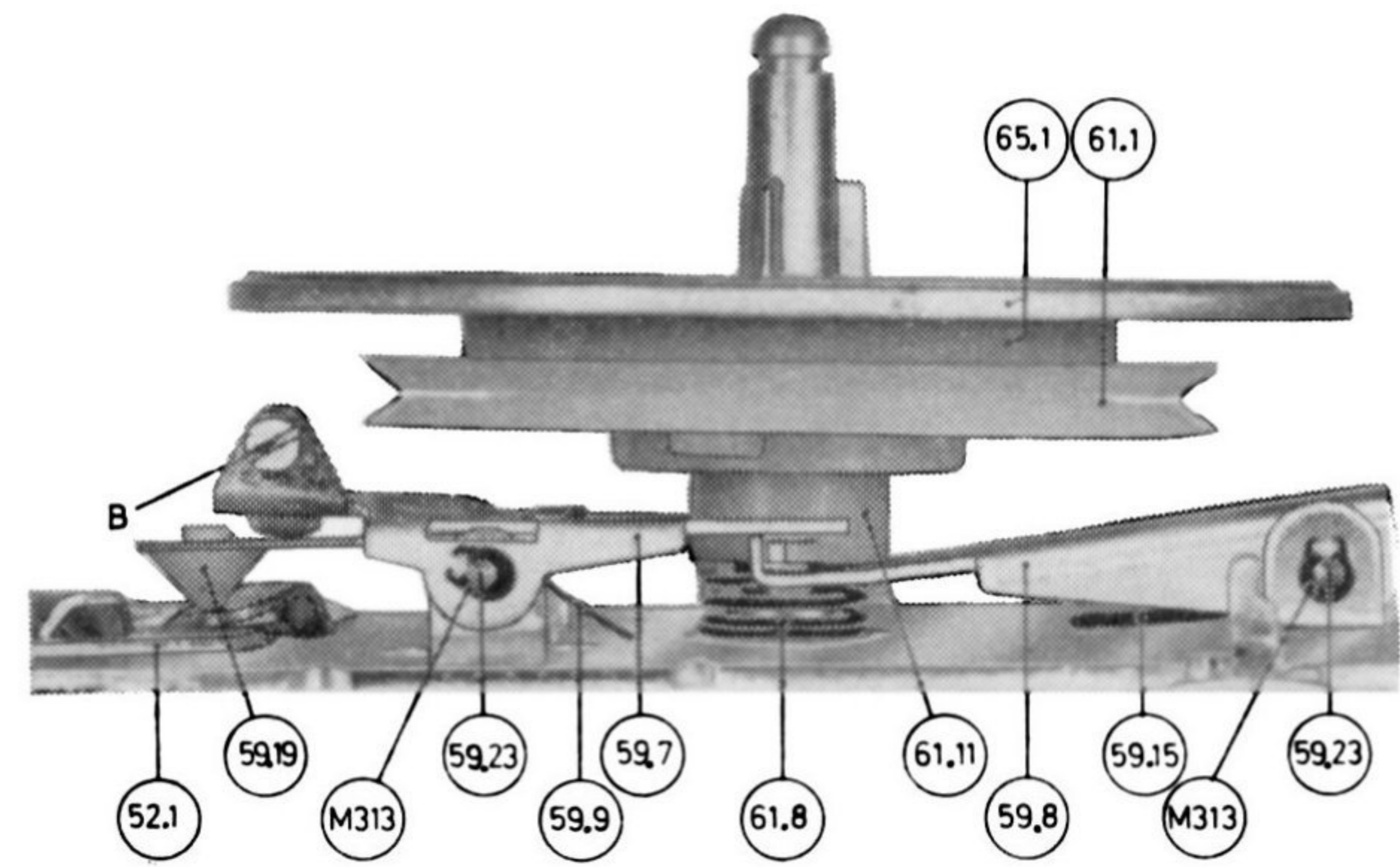

Fig. 25.

The take-up turntable

The take-up turntable (65.1) has a reduced friction with the pulley disc (61.1) in this position. The torque of the take-up turntable (65.1) should be sufficient to take-up the tape in record or playback modes. Ref. fig. 25.

The trip bar (52.1) has moved, and the delrin button (59.19) on the upper clutch lever (59.7) is in the middle position, pressing down the spring loaded lower clutch lever (59.8). The delrin lugs on the cartridge (61.11) are released from any tension, and the pulley disc (61.1) is pressing against the turntable (65.1) only by the tension of the compression spring (61.8).

Adjustments

Adjust the height of the upper clutch lever (59.7) by the screw (B) until the delrin lugs on the cartridge (61.11) is in the center position between upper and lower clutch levers (59.7, 59.8).

The torque of the take-up turntable (65.1) should be 12–25 g (1/2–1 oz) acting on an arm of 8 cm (3 1/2"). Recheck all other positions of the operating lever and finally seal the adjustment screw B.

4.3.5 Neutral

The motor power is shut off, and the pulley discs (61.1, 61.2) are not running.

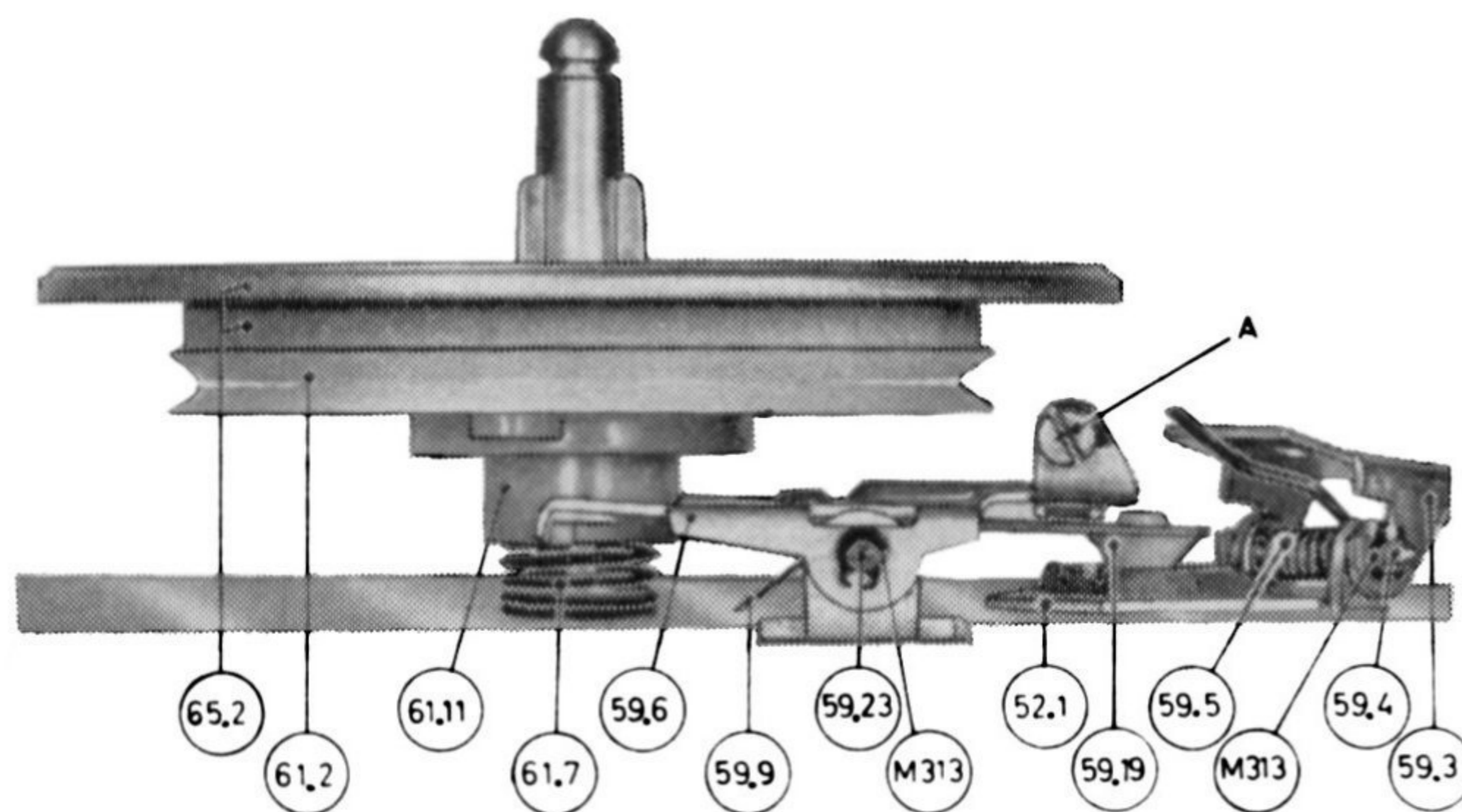

Fig. 26.

The supply turntable

The supply turntable (65.2) has maximum obtainable friction with the pulley disc (61.2) in this position. Ref. chapter 4.3.2, fast rewind.

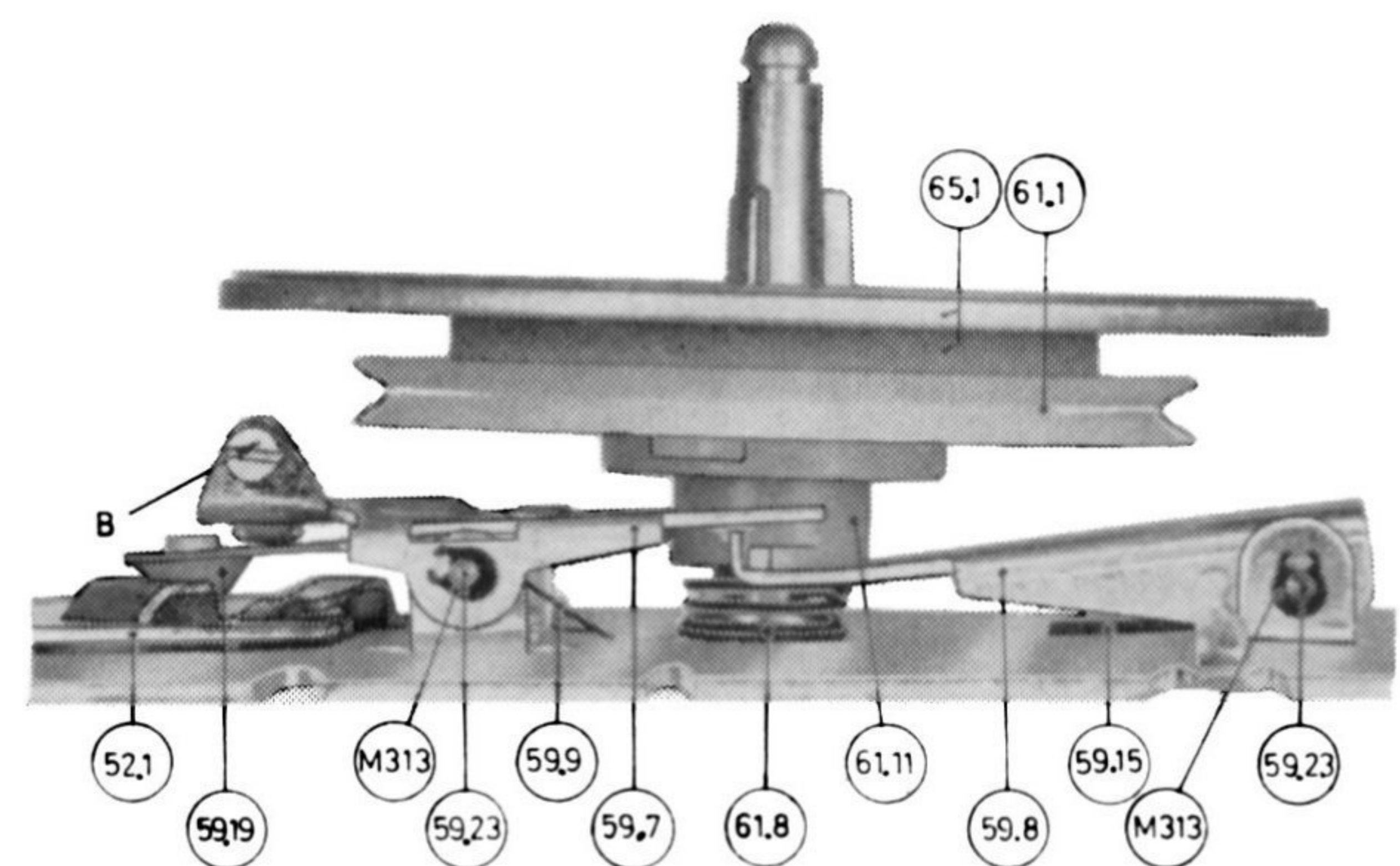

Fig. 27.

The take-up turntable

The take-up turntable (65.1) has maximum obtainable friction with the pulley disc (61.1) in this position. Ref. chapter 4.3.3, fast wind.

4.3.6 Free

The motor power is shut off and the pulley discs (61.1, 61.2) are not running.

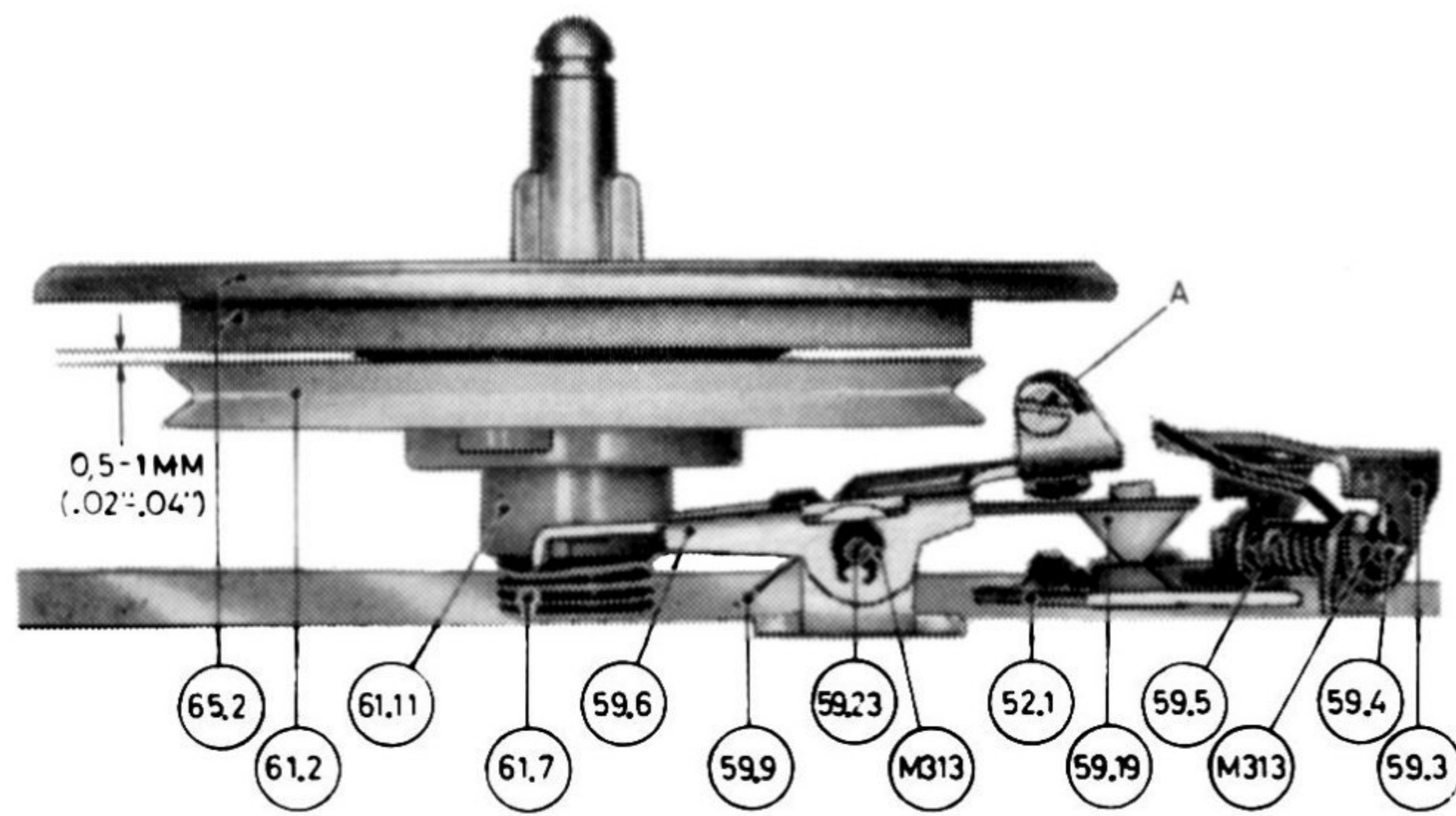

Fig. 28.

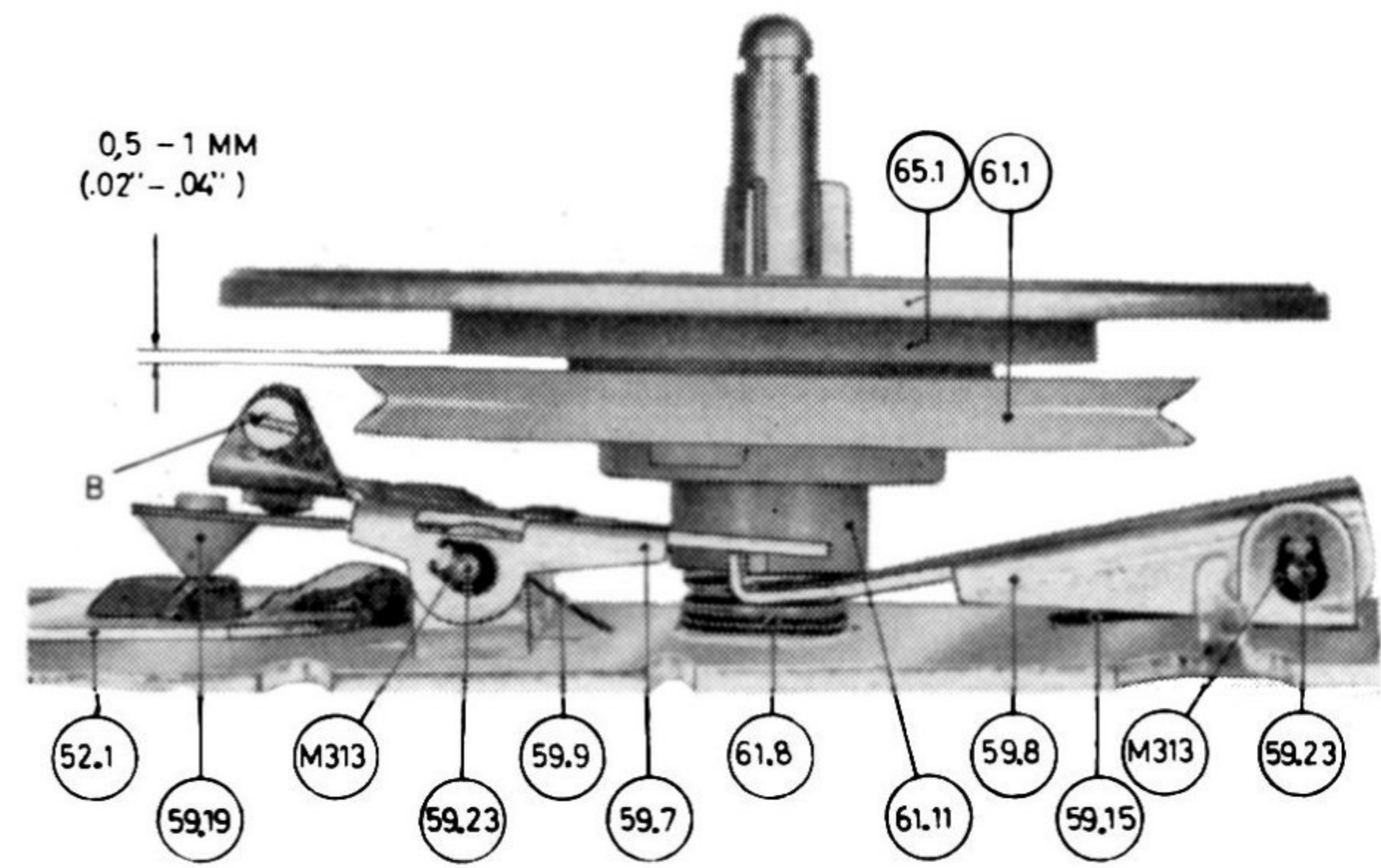

Fig. 29.

The supply turntable

The supply turntable (65.2) is completely disengaged from the pulley disc (61.2) and free-running in this position. Ref. chapter 4.3.3, fast wind.

The take-up turntable

The take-up turntable (65.1) is completely disengaged from the pulley disc (61.1) and free-running in this position. Ref. chapter 4.3.2, fast rewind.

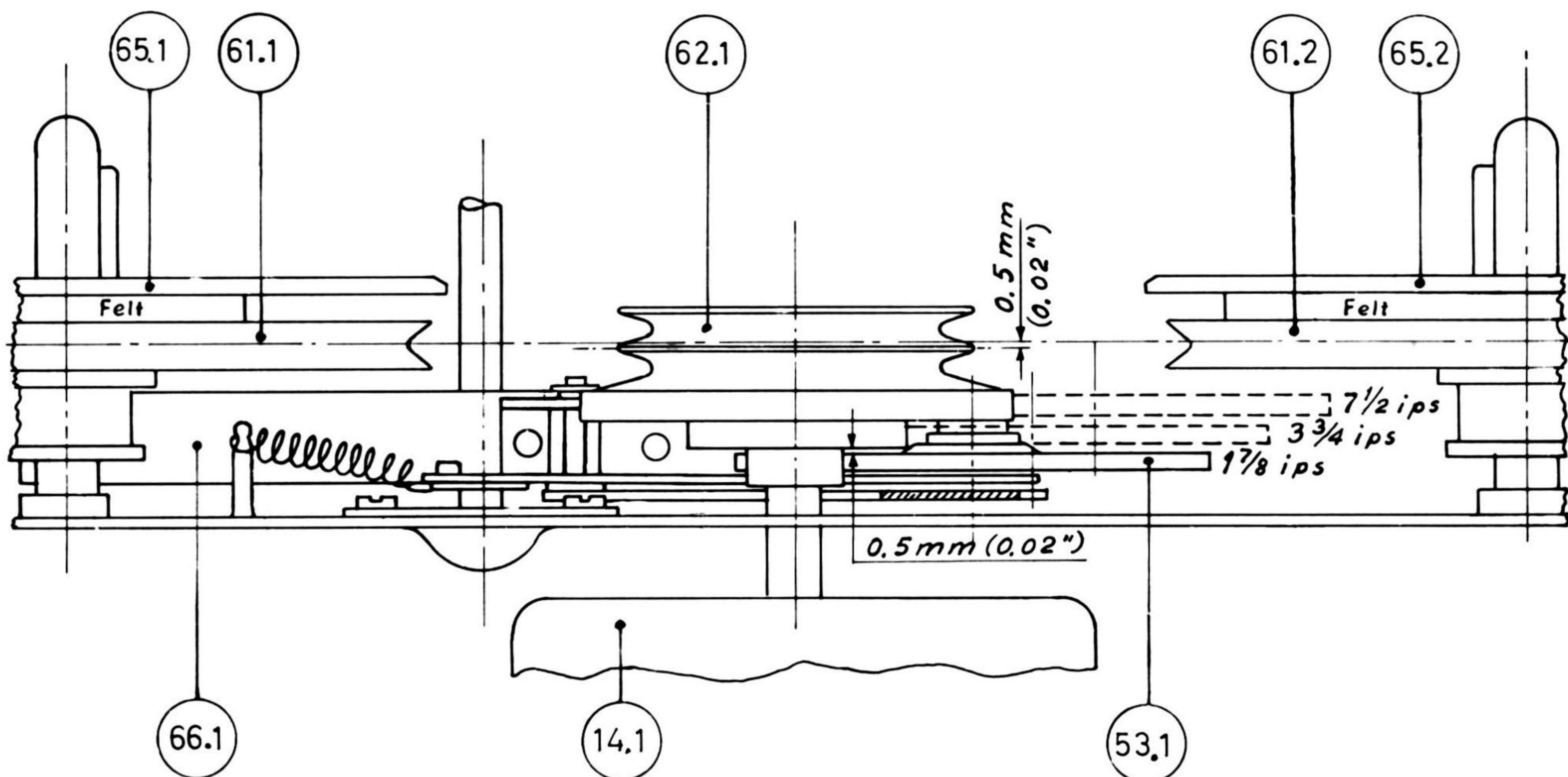

Fig. 30. The alignment of the motor pulley.

Note: Ref. fig. 58 for tape recorders with serial No. below 720 000.

4.4 The motor pulley

The driving mechanism with the speed transfer wheel (53.1) engaged in the $1\frac{7}{8}$ i.p.s. track on the motor pulley (62.1) is shown in fig. 30. The motor pulley (62.1) has three tracks with different diameters for the speed transfer wheel (53.1), corresponding to the speeds $1\frac{7}{8}$, $3\frac{3}{4}$, and $7\frac{1}{2}$ i.p.s.

Adjustments

The vertical position of the motor pulley (62.1) is adjusted with the operating lever (54.1) in neutral position. The dividing rib of the motor pulley (62.1) should be set 0.5 mm (.02") below an imaginary line drawn between the bottoms of the V-shaped grooves in the pulley discs (61.1, 61.2).

4.4.1 Threading of the rubber drive belt

The rubber drive belt (62.2) is crossthreaded as shown in fig. 5. The belt is running in the upper groove in front of the pulley (62.1), and in the lower groove at the rear of the pulley. The crossing should lie between the supply turntable (65.2) and the motor pulley (62.1).

4.5 THE SPEED TRANSFER WHEEL

The speed transfer wheel (53.1) is attached to the mounting arm (53.3) and is driven by the motor pulley (62.1). The speed transfer wheel (53.1) in turn, drives the fly-wheel (66.1). The spring (53.5) secures the contact of the speed transfer wheel (53.1) between the motor pulley (62.1) and the flywheel (66.1). Ref. fig. 5 and 30.

Adjustments

The speed selector bracket (79.3) is adjusted until the mounting arm for the speed transfer wheel (53.3) is parallel to the lower mounting plate (71.1) (unscrew the two screws M113). The spacing between the mounting arm (53.3) and the lower mounting plate (71.1) should be approx. 1 mm (.04"). Ref. fig. 33.

The vertical position of the speed transfer wheel (53.1) is adjusted by adding or subtracting turbax washers between the transfer wheel holder (53.2) and the mounting arm for the transfer wheel (53.3). The spacing between the speed transfer wheel (53.1) and the higher speed track on the motor pulley (62.1) should be approx. 0.5 mm (.02") in the 1⁷/₈ i.p.s. and 3³/₄ i.p.s. position.

The vertical position of the speed transfer wheel (53.1) should be minimum 1 mm (.04") below the upper rim of the flywheel (66.1) in the 7¹/₂ i.p.s. position. The flywheel (66.1) is lifted, if necessary, by adding an extra thrust washer (66.81) in the lower flywheel bearing. Ref. chapter 4.7.

The horizontal alignment of the speed transfer wheel (53.1) is adjusted by bending the transfer wheel holder (53.2) (tool No. 6) until the speed transfer wheel (53.1) runs parallel to the flywheel (66.1).

4.6 THE LIFTING MECHANISM

The design of the lifting mechanism is shown in fig. 33.

The lifting arm (59.18) with the parallel arm (53.7) and the adjustment arm (53.8) is located between the upper and the lower mounting plates (71.2, 71.1). The lifting arm (59.18) is linked to the eccentric segment (59.17) while the parallel arm (53.7) is connected between the lifting arm (59.18) and the transfer wheel holder (53.2).

The lifting mechanism releases the speed transfer wheel (53.1) from contact with the motor pulley (62.1) and the flywheel (66.1) in all positions of the operating lever (54.1) except normal forward drive.

Adjustments:

Ref. fig. 33.

Loosen screw A. The lifting between the speed transfer wheel (53.1) and the motor pulley (62.1) is individually adjusted for the three speeds by bending the splits X, Y and Z on the lifting arm (59.18), corresponding to the speeds 7¹/₂, 3³/₄ and 1⁷/₈ i.p.s. The lifting is occasioned by a relatively small movement of the operating lever (54.1) from normal forward drive to neutral. The lifting should be completed before the motor current is shut off by the micro-switch (33.3).

The clearance between the motor pulley (62.1) and the speed transfer wheel (53.1) at all speeds should be minimum 3 mm when the operating lever (54.1) is in neutral position.

Set the speed selector to 1⁷/₈ i.p.s. tape speed and the operating lever to neutral position. Turn the adjustment arm (53.8) until a spacing of 0,5 mm (.02") is obtained between the speed transfer wheel (53.1) and the flywheel (66.1). Turn the speed selector to 3³/₄ and 7¹/₂ i.p.s. tape speed and check that the spacing is min. 0,5 mm (.02") for both positions. Re-adjust if necessary and re-seal the adjustment screw A.

Note: The lifting mechanism has been modified from serial No. 720 001. The new design of the mechanism releases the speed transfer wheel from contacting the motor pulley and the flywheel in neutral position of the operating lever.

Ref. fig. 53, 54, 58 and 59 for tape recorders with serial No. below 720 000.

4.7 THE FLYWHEEL WITH THE CAPSTAN

The flywheel shaft acts as the capstan (66.2), and is mounted in two selflubricating and selfadjusting bearings (66.3). Ref. fig. 31.

Adjustments

The vertical position of the capstan (66.2) is aligned with the special tool No. 5 inserted on top of the capstan as shown in fig. 32.

The two screws (M125) are loosened, and correct position of the capstan (66.2) is obtained when all three legs of the tool No. 5 touches the upper mounting plate (71.2).

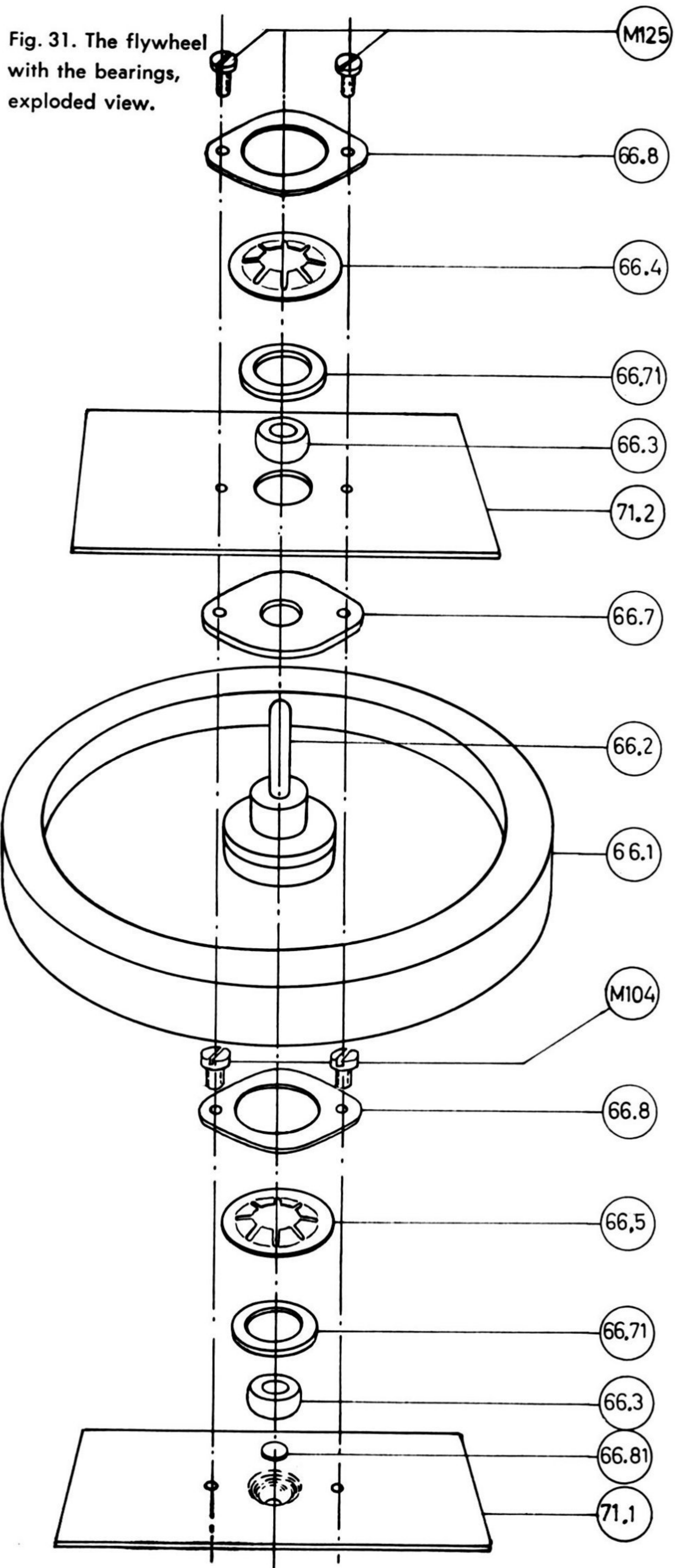

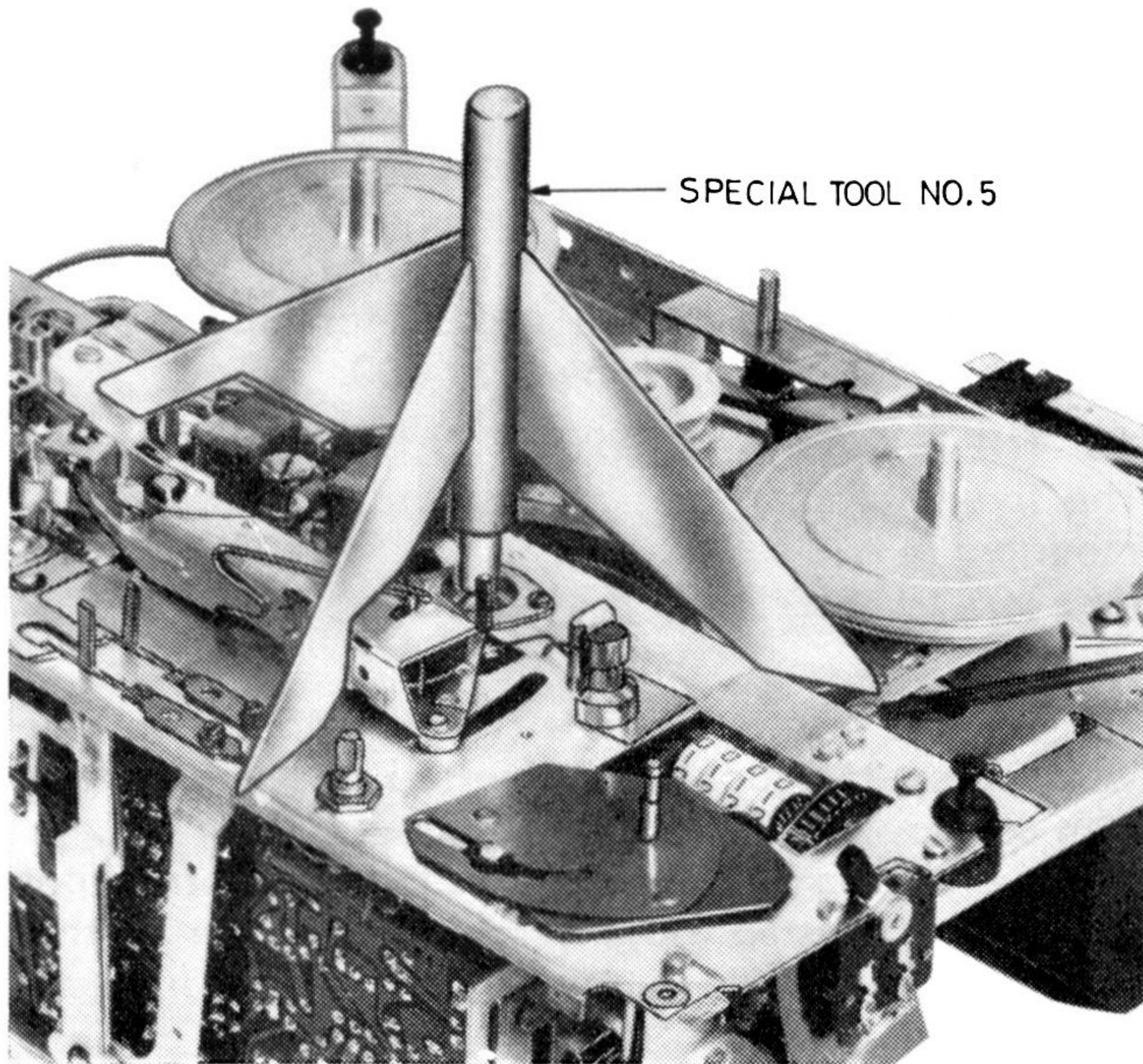

Fig. 32. Alignment of the capstan with tool No. 5.

4.7.1 The brake for the flywheel

The brake spring (66.6) for the flywheel (66.1) is attached to the lifting arm for the speed transfer wheel (59.18). Ref. fig. 5.
The brake is engaged in all positions of the operating lever (54.1) except normal forward drive.

Adjustments

The braking action is adjusted by bending the brake spring (66.6).
The motor pulley (62.1) and the flywheel (66.1) should stop simultaneously when the operating lever (54.1) is moved from normal forward drive to neutral position.
Ascertain sufficient spacing between the felt pad (66.9) and the flywheel (66.1) in normal forward drive position of the operating lever (54.1).

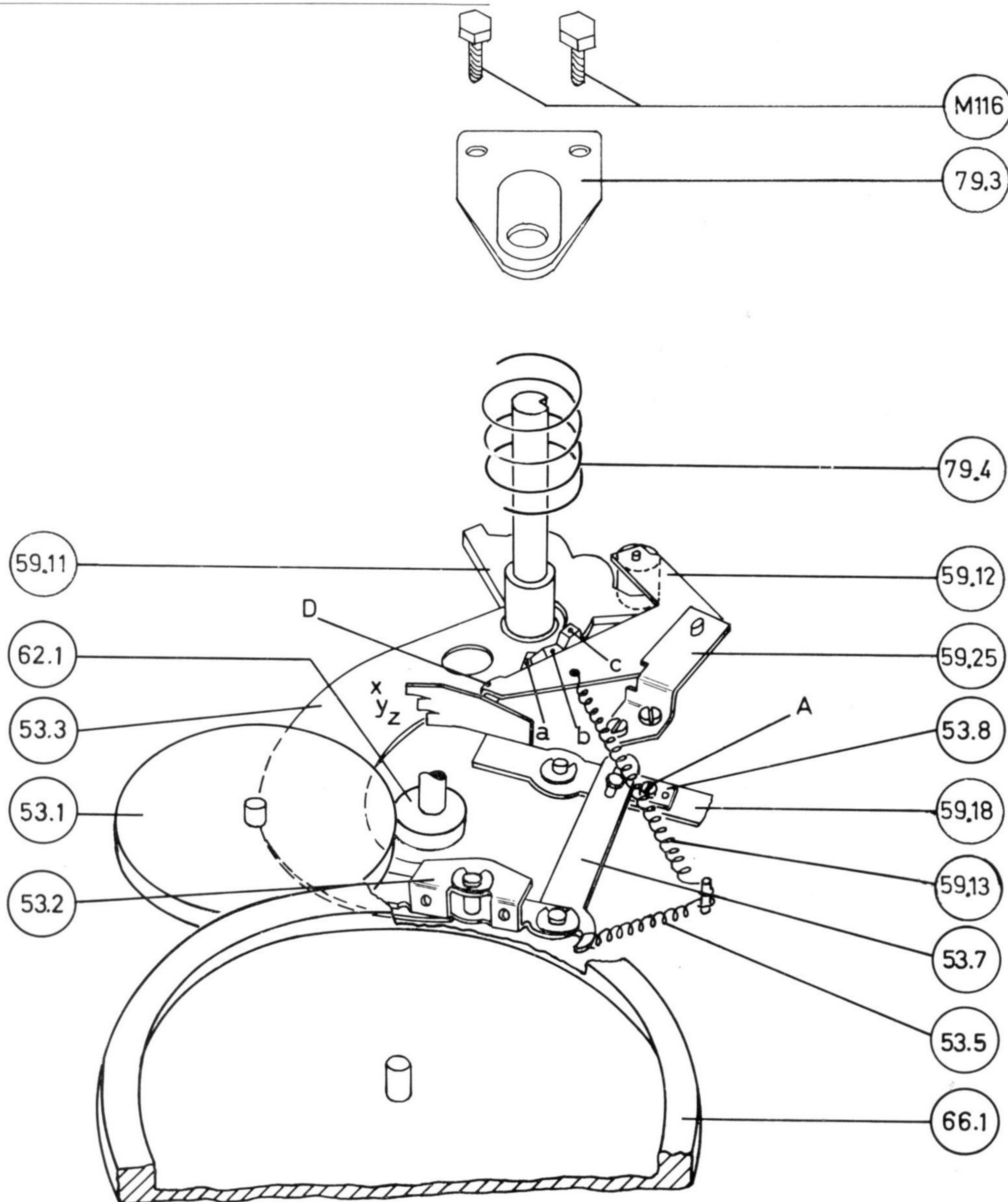

Fig. 33. The speed change mechanism.

Note: Ref. fig. No. 59 for tape recorders with serial No. below 720 000.

4.8 THE SPEED CHANGE MECHANISM

The speed change mechanism is designed as shown in fig. 33.

The speed transfer wheel (53.1) is engaged with the lowest track on the motor pulley (62.1), and the mounting arm for the speed transfer wheel (53.3) is pressed against the lowest level (level a) on the cam disc (59.11) in the $1\frac{7}{8}$ i.p.s. position.

The speed transfer wheel (53.1) will be disengaged from the motor pulley (62.1), and moved out horizontally approx. 1", when the speed selector knob (53.4) is turned toward the $3\frac{3}{4}$ i.p.s. position. This horizontal movement is accomplished by the cam disc arm (59.12), which roller rests against the curvature of the cam disc (59.11). The cam disc arm (59.12) presses against the mounting arm for the speed transfer wheel (53.3) in point D.

The vertical lifting of the mounting arm for the speed transfer wheel (53.3) is accomplished by the slope of the cam disc (59.11) between the levels a and b. The slope presses the mounting arm for the speed transfer wheel (53.3) upwards from the level a ($1\frac{7}{8}$ i.p.s. position) to the level b ($3\frac{3}{4}$ i.p.s. position) during the rotation of the speed selector knob (53.4).

Adjustments

The spacing at point D between the cam disc arm (59.12) and the mounting arm for the speed transfer wheel (53.3) should be 0.5 mm (.02") with the operating lever (54.1) in normal forward drive. The spacing is adjusted by bending the nose of the cam disc arm (59.12). Remove the motor pulley (62.1) to make this alignment.

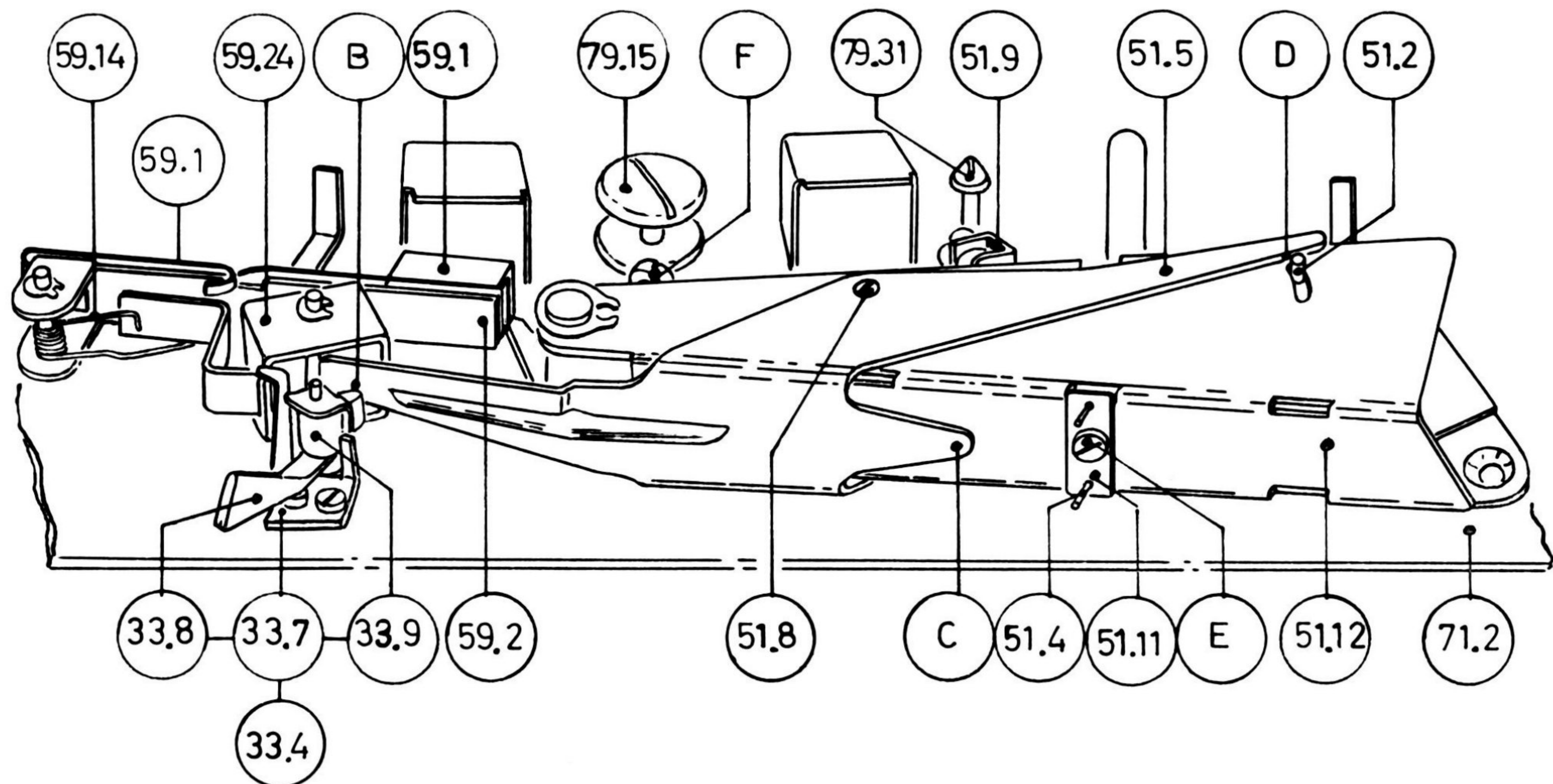

Fig. 34. The momentary start-stop mechanism.

4.9 THE MOMENTARY START-STOP FEATURE

The momentary start-stop mechanism (33.4) is designed as shown in fig. 34.

The delrin bushing (33.9) will press against the pressure wheel lever (51.5) in point B when the start-stop lever (33.8) is moved to stop position. The pressure wheel lever (51.5) moves the pressure wheel shaft (51.2) with the pressure wheel (51.1) away from the capstan (66.2) and activates the tape brake (51.9).

Adjustments

Move the operating lever to normal forward drive position and set the momentary start-stop lever in

«STOP» position. Adjust the pressure wheel lever (51.5) by bending the flat part B to obtain a spacing of approx. 0.5 mm (.02") between the pressure wheel (51.1) and the capstan (66.2). Ascertain a play of approx. 0.2 mm (.012") between the pressure wheel lever (51.5) and the transfer bracket (59.24).

Start the mechanism by moving the start-stop lever to the left position. Adjust the pressure wheel lever (51.5) by bending the tongue C to obtain a spacing of approx. 1 mm (.04") between the pressure wheel shaft (51.2) and the pressure wheel lever (51.5) at point D. Make sure that the space between the pressure wheel lever (51.5) and the start-stop lever (33.8) is approx. 0.5 mm (.02").

4.10 THE PRESSURE PAD

The pressure pad (59.27) is located in front of the erase head and is introduced to secure maximum erasure, and to ensure constant friction for the tape, when the recorder is operating in normal forward drive. Ref. fig. 10 and 34. The pressure pad arm (59.2) is activated by the pressure wheel lever (51.5) and the transfer bracket (59.24). The pressure pad (59.27) is pressing against the tape and the erase head in normal forward drive, and is completely disengaged in all other positions of the operating lever (54.1).

Adjustments

The pressure pad (59.27) should be cleaned occasionally, as the accumulation of dust and iron oxide

particles might seriously affect the erasure and the tape movement.

Note: Do not soak the felt pad with any liquid.

The spring with felt for the pressure pad (59.1) is designed as a snap-on type, and can easily be pulled out by bending the two tags on the hard brass spring away from the slots in the pressure pad arm (59.2).

The tension of the pressure pad (59.27) against the erase head, in normal forward drive position, should be 75–100 g ($2\frac{5}{8}$ – $3\frac{1}{2}$ oz). This tension is corrected by adjusting the tension of the spring (59.14) for the pressure pad.

4.11 THE AUTOMATIC END STOP SWITCH

The actuating spring (79.17) for the end stop switch is located in the slot of the right tape guide (79.14). The microswitch (33.2) is mounted under the upper mounting plate (71.2) ref. fig. 8 and 10.

The microswitch (33.2) shuts off the motor when the tape runs out or if the tape breaks. The switch works independent upon the position of the operating lever (54.1).

Adjustments

The operating point of the microswitch (33.2) is adjusted by bending the actuating spring (79.17) in point A. Ref. fig. 35. The operating point is set 0.5 mm (.02") in front of the imaginary line x–x, when the actuating spring (79.17) is moved from the rest position towards the front of the upper mounting plate (71.2).

The actuating spring shall run free inside the tape guide slot without sticking. The width of the slot is adjusted to 2 mm (.08") by bending the bracket in point B. Ref. fig. 35.

The vertical position of the actuating spring (79.17) is adjusted as shown in fig. 36. The vertical part of the spring should cover approx. 3 mm ($\frac{1}{8}$ ") of the tape. Misalignments could cause the tape to be squeezed out of the tape guide.

Ascertain sufficient clearance between the upper part of the actuating spring marked D and the front trim cover (73.1) when tape is inserted.

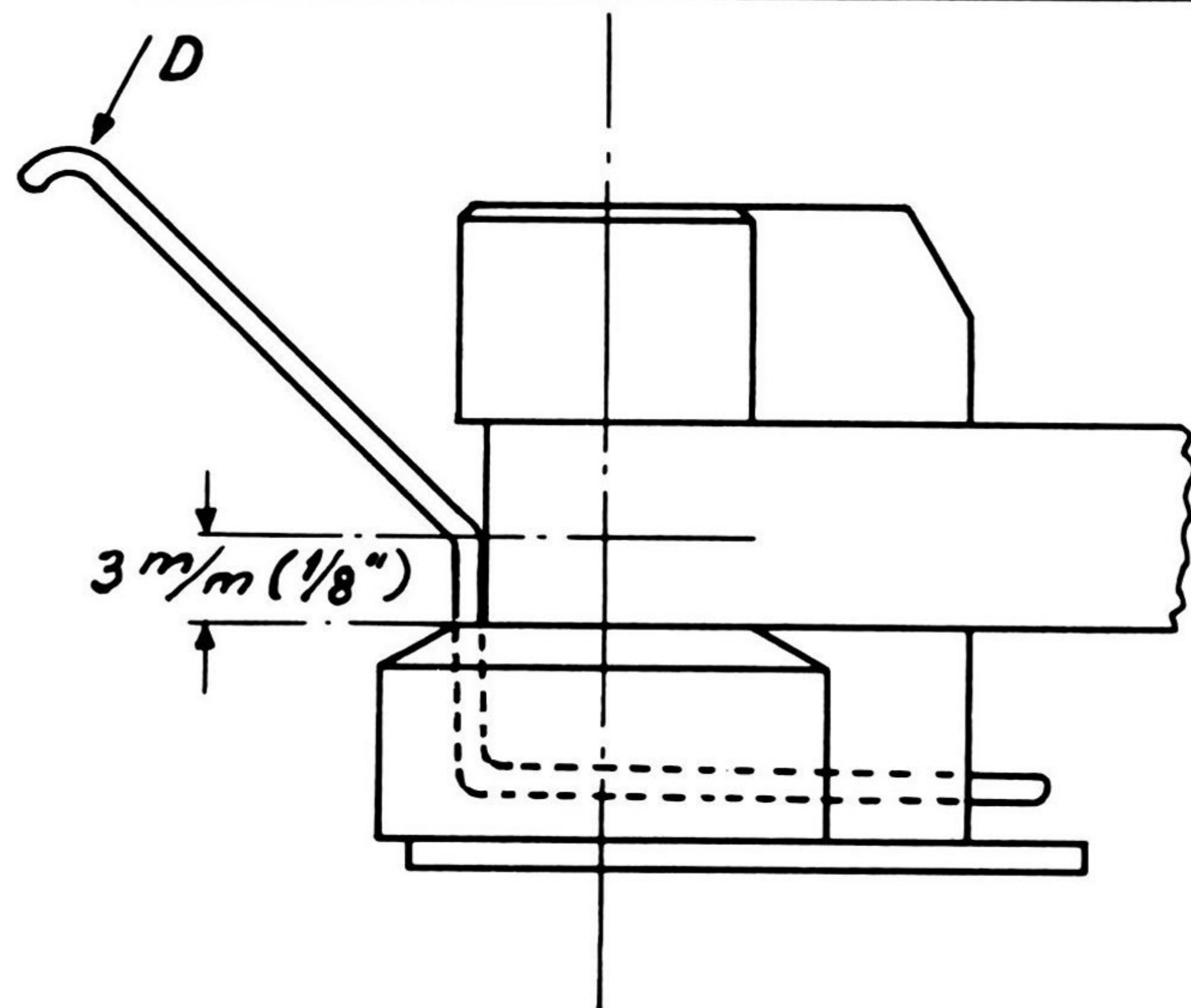

Fig. 36. Vertical adjustment of the end stop switch.

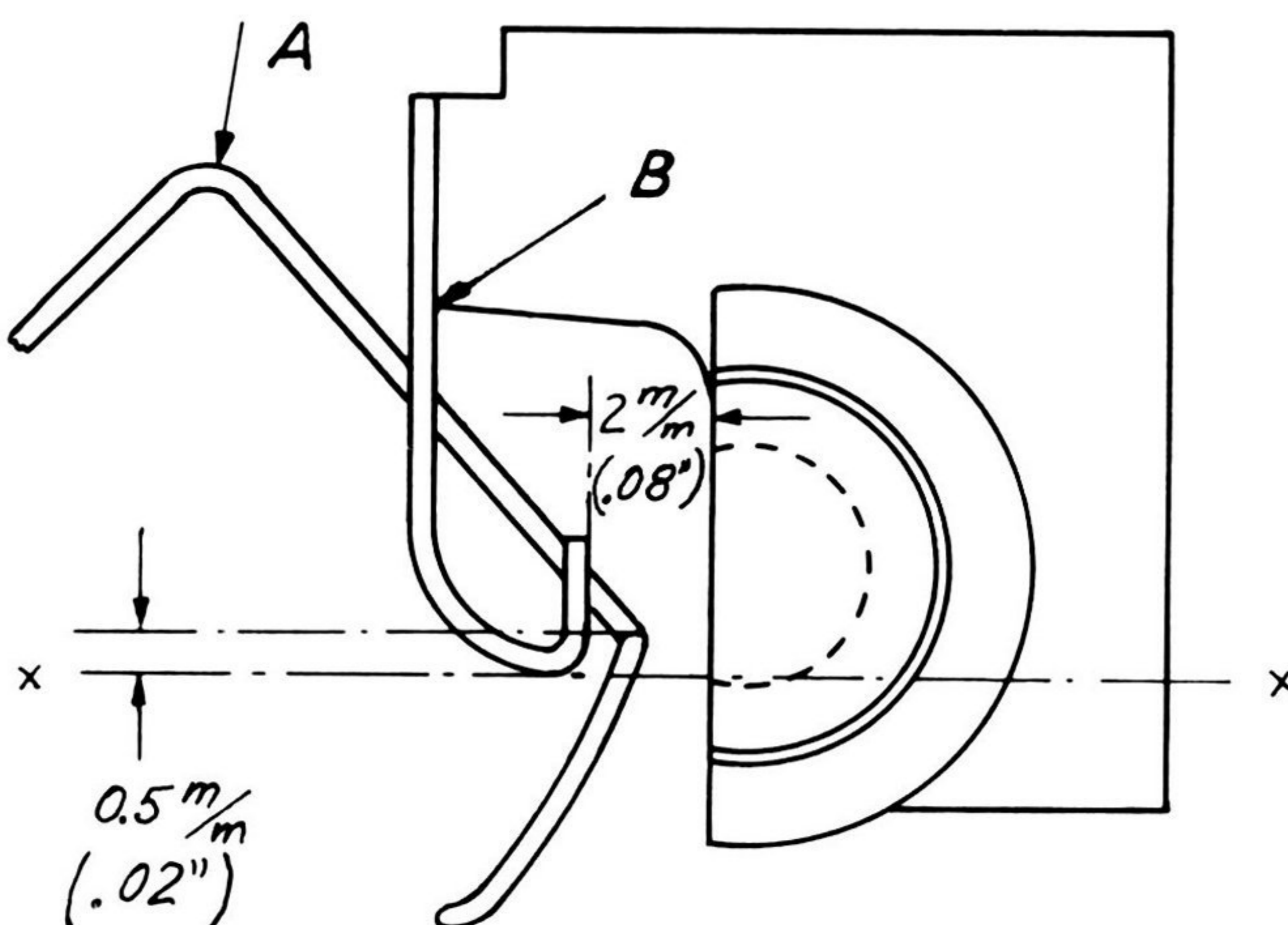

Fig. 35. Horizontal adjustment of the end stop switch.

4.12 THE REVOLUTION COUNTER

The revolution counter (79.23) is located between the upper and the lower mounting plates (71.2, 71.1), behind the operating lever (54.1). The counter (79.23) is driven by a rubber belt (69.3) and a pulley disc (69.1) attached to the shaft of the take-up turntable (65.1). Ref. fig. 8 and 49.

Adjustments

The pulley disc for the revolution counter (69.2) is mounted flush with the counter shaft. The pulley disc (69.1) is mounted tight up against the lock spring (79.8) for the take-up turntable. Misalignment of the vertical position of the pulleys might cause the rubber belt (69.3) to fall off.

4.13 ASSEMBLING THE TOP COVER

The top cover is attached to the recorder as shown in fig. 37.

Vertical alignment of the top cover

Two thick rubber washers (74.5) have been introduced between the top cover and the mounting brackets. By tightening the two screws (M130) slightly, the rubber will be compressed and allow the necessary vertical adjustment of the top cover. Ref. fig. 37.

The vertical position of the top cover should be adjusted to ascertain sufficient spacing between the plastic tape reels and the top cover in all modes of operation.

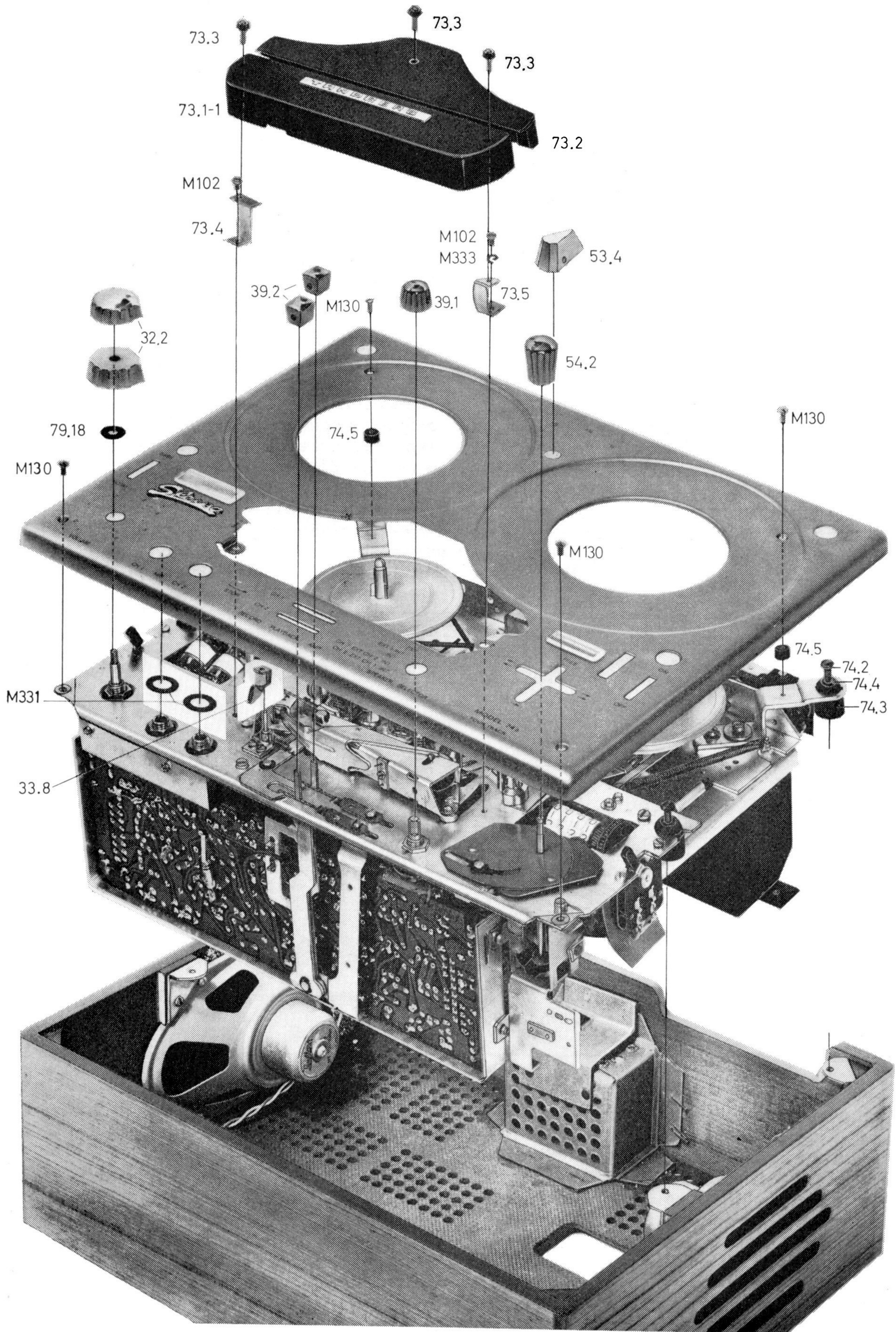

Fig. 37.

5.0 The electronic circuits, detailed description and adjustment instructions

Two playback pre-amplifier output stages and one center channel output terminal have been introduced on the models 74B — 72B in addition to the new speaker selector switch. The models 74 — 72 and 74B — 72B are otherwise similar in all respects.

5.1 THE MAIN ELECTRONIC UNITS, BLOCK DIAGRAM

The block diagram for the Tandberg tape recorder models 74 — 72 and 74B — 72B is shown below. Ref. fig. 38.

The tape recorders are equipped with the following separate units:

- 2 Record pre-amplifiers
- 2 Record/power output amplifiers
- 2 Record level indicator circuits

- 1 Oscillator
- 2 Playback pre-amplifiers
- The power supply
- The switching system.

For the models 74B and 72B only:

- 2 Playback pre-amplifier output stages.

The different units can be interconnected in various combinations by the switching system, creating a very flexible tape recorder.

The amplifiers are equalized to conform with the N.A.B. standards.

The amplifiers are identical for the two channels, and only the amplifiers for the upper track are therefore explained in the following discussions.

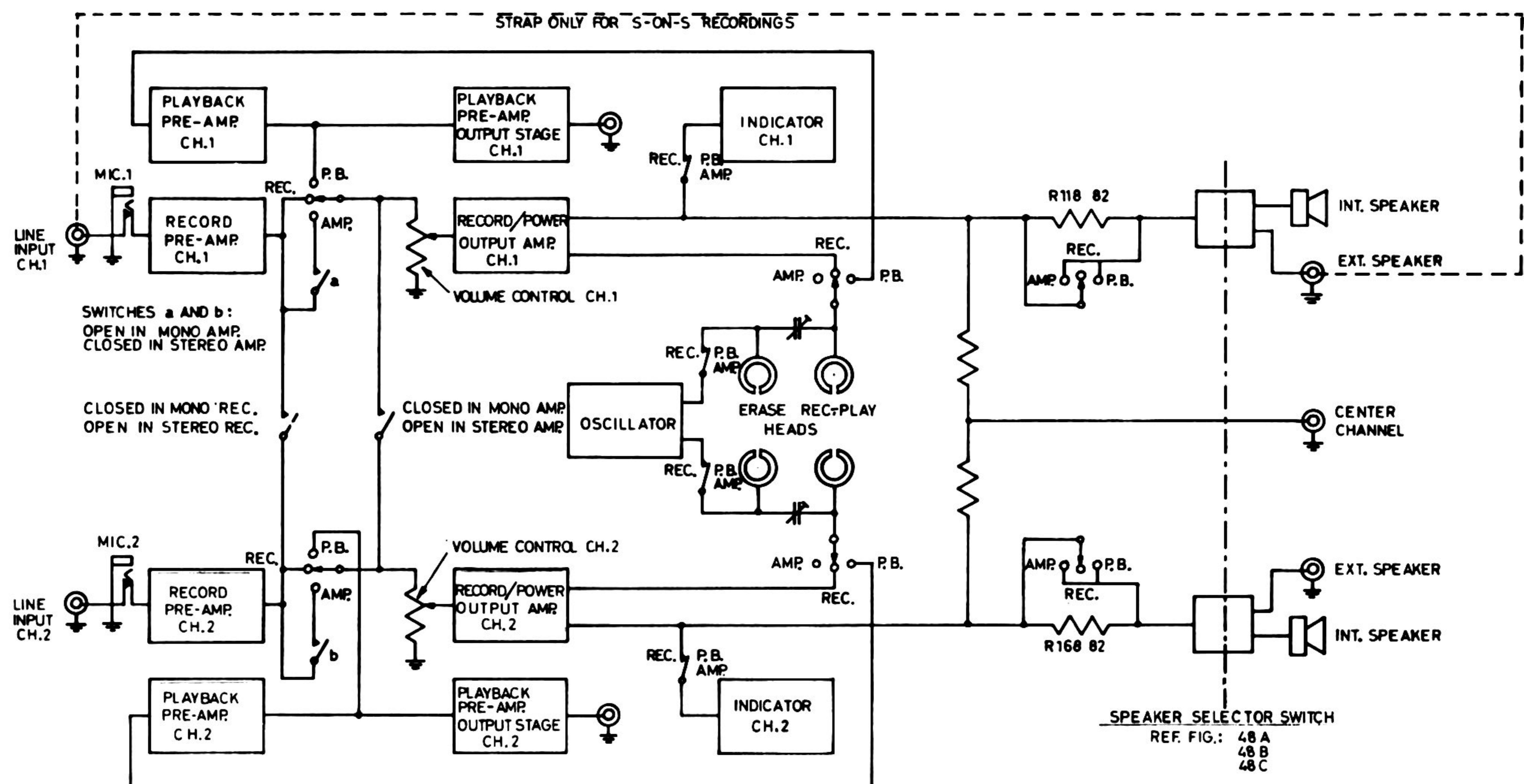

Fig. 38. Block diagram models 74 — 72 and 74B — 72B. The diagram shows the switches in stereo recording. (The playback preamp. output stages ch. 1 and ch.2 are furnished only on the models 74B and 72B.)

5.1.1 The record pre-amplifier

The schematic for the record pre-amplifier is shown below. Ref. fig. 39.

The record pre-amplifier is a one stage amplifier using one half of the double triode ECC83 (12AX7).

The record pre-amplifier is equipped with one microphone input and one line input. The line input circuit is furnished with a potentiometer (R551) for adjustment of the signal voltage being fed to the grid of V1A.

The input sensitivity is adjustable between 2—2.5 mV and 7 V and at the same time the variation of the input impedance will be between .1—5 Mohm.

C501 has been introduced to block DC voltage from the grid of V1A.

Note: The microphone jack disconnects the line input from the grid of V1A when the microphone plug is inserted.

The output signal from the record pre-amplifier passes the contacts A 21 — 20, A 18 — 17 and B 1 — 2 and is fed to the top of the volume control R4 of the record/power amplifier.

The frequency response of the record pre-amplifier is flat. No equalization has been introduced.

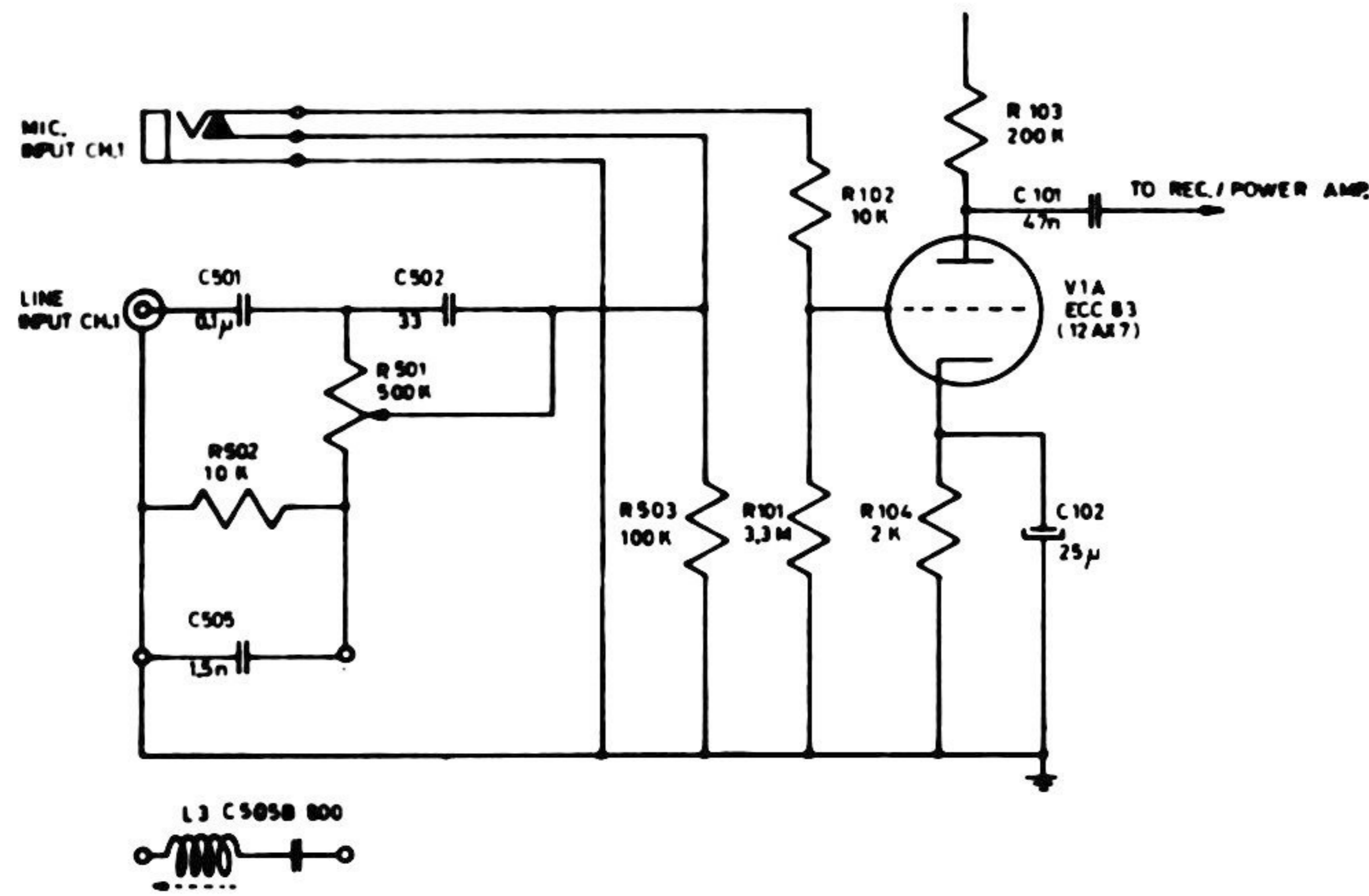

Fig. 39. The record pre-amplifier, schematic.

5.1.2. The FM-multiplex filter

Ref. fig. 39.

A 19 kc/s FM-multiplex filter C505B – L3 replaces the capacitor C505 in the record pre-amplifier and is introduced on tape recorders sold in certain territories. The 19 kc/s pilot signal that might appear on the output terminals of the FM-multiplex tuner is rejected by the series resonant circuit – C505B – L3 when the input level set potentiometers R501 and R551 are turned all the way down (counter clockwise).

5.1.3 The record/power output amplifier, as record amplifier

The schematic for the record/power output amplifier is shown below. Ref. fig. 40.

The amplifier is a two stage combined record/power output amplifier using one section of the double triode ECC83 and the pentode EL84 (ref. note). The amplifier can be switched between record amplifier or power output amplifier by the function selector switch. Ref. chapter 5.1.5 for discussions of same as power output amplifier.

The entire record equalization is obtained by the variable filter in series with the record/playback head (R120, R120B, C113, C114, and C115). Mainly the high frequencies are compensated in the record amplifier. Ref. fig. 41. The speed compensation is obtained by R120, R120B – C115 (7 1/2 ips), R120, R120B – C114, C115 (3 3/4 ips), or R120, R120B – C113, C114 (1 7/8 ips). R120B is installed as an adjustment resistor. The frequency response will increase approx. 2 dB at 15 000 c/s by removing R120B.

The equalization switch is linked to the speed selector knob, and correct combination of the capacitors is automatically obtained when the tape speed is changed.

The negative feedback circuit (C206 – C207 and R209 – R210) from the secondary winding of the output

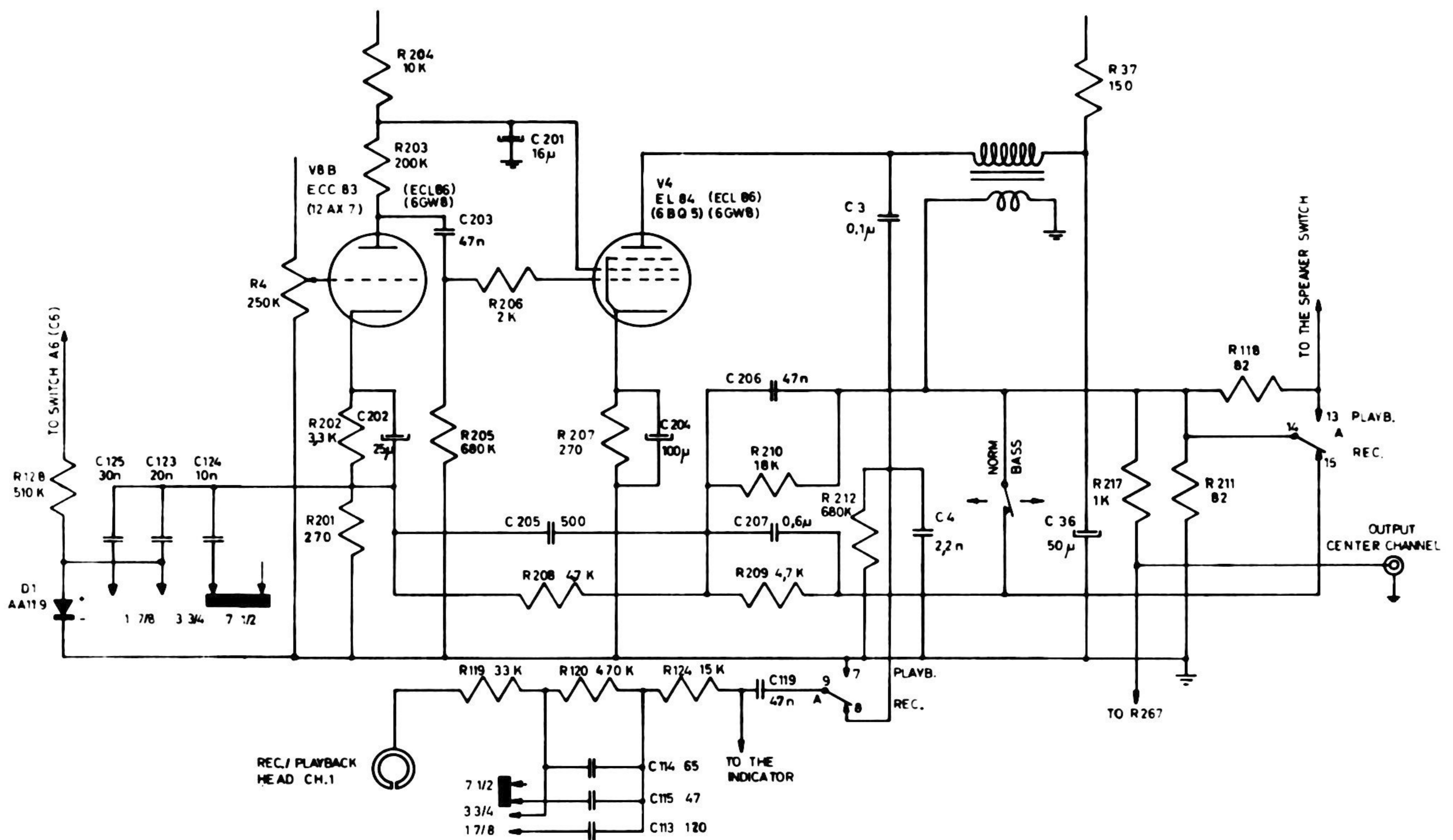

Fig. 40. The record/power output amplifier in record position.

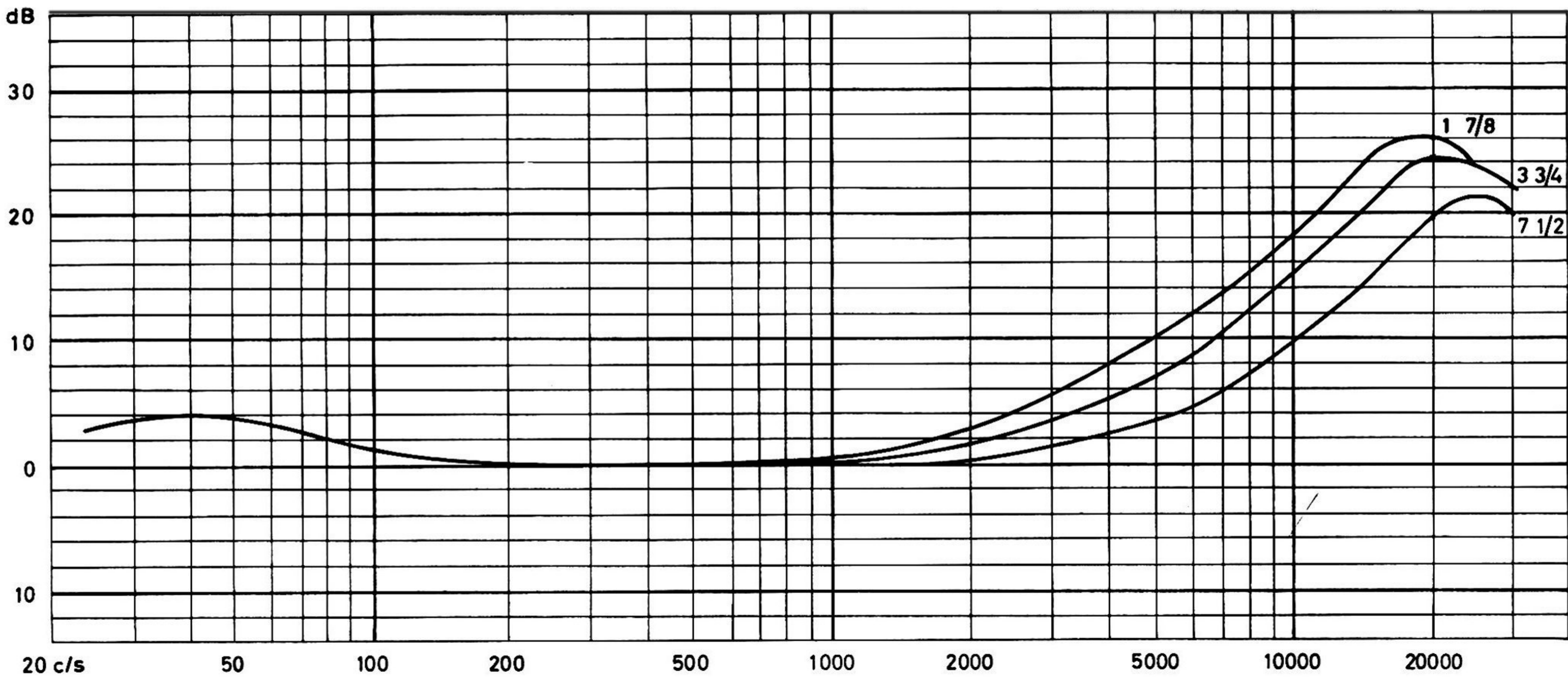

Fig. 41. The response curves for the record/power output amplifier in record position.

transformer to the cathode of V8B increases the amplification approx. 4 dB at 50 c/s.

The capacitors C123, C124, C125, the diode D1, and the resistor R128 increases the high frequency amplification during recording. The diode D1 is connected to the switch A6 in series with the resistor R128. The diode D1 is forward biased when the function selector switch is in record position and the capacitor C123 is connected to ground. The speed compensation is automatically obtained by the equalization switch.

The potentiometer R4 acts as the record gain control during recording.

The bass switch is shortcircuited across the switch A14 – 15 in record position, and is inoperative.

The recording signal is fed to the output transformer from the anode of V4. The secondary winding of the transformer is connected to the speaker in series with R118. The recording signal is being monitored with a reduced volume during the recording.

Note: The tube ECL86 has been used on the models 74 and 72. It has been replaced by one section of the double triode ECC83 and the pentode EL84 on models 74B and 72B. For further information ref. chapter 5.8.

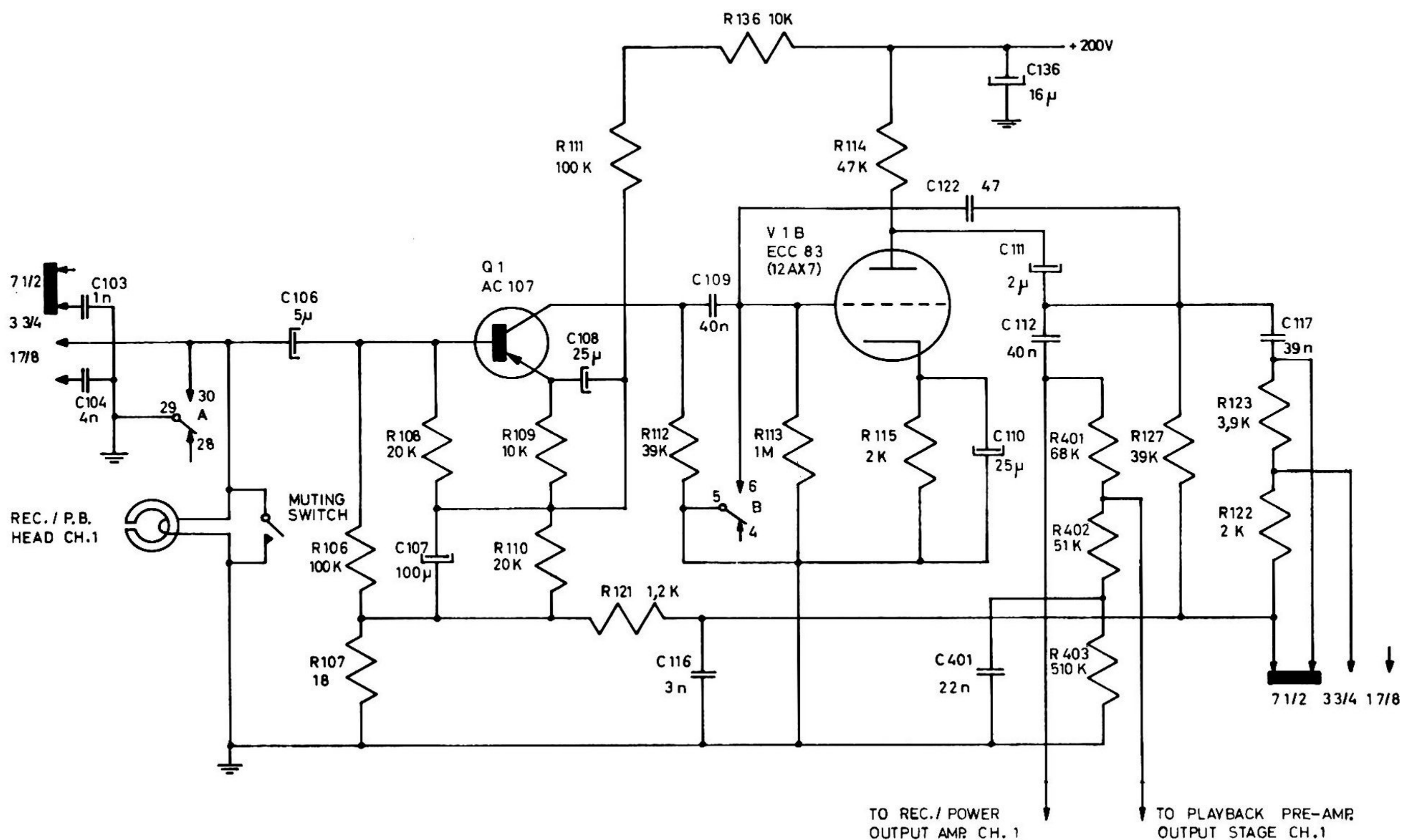

Fig. 42. The playback pre-amplifier, schematic.

5.1.4 The playback pre-amplifier

The schematic for the playback pre-amplifier is shown below. Ref. fig. 42.

The playback pre-amplifier is a two stage amplifier using one transistor AC107 as the first stage, and one section of the double triode ECC83 (12AX7) as the second stage.

The playback equalization is obtained by the following circuits:

1. The negative feedback circuit from the anode of V1B to the emitter of the transistor Q1. The amplification of the low frequencies is increased to conform with the N.A.B. standards.
2. The speed compensation is obtained by the combination of R127 — C117 (7¹/₂ i.p.s.), R127 — C117, R122 (3³/₄ i.p.s.), or R127 — C117, R123, R122 (1⁷/₈ i.p.s.).
3. The record/playback head, together with the capacitors C103 or C104, form a resonant circuit and

compensates for playback losses at high frequencies.

4. The capacitor C116 is installed to give a slight increase of the high frequency amplification.
5. The capacitor C122 forms a feedback circuit for the oscillator voltage.

The equalization switch is linked to the speed selector knob, and correct equalization for the different speeds will be obtained automatically, when the speed is changed. Ref. fig. 43.

The switch B5 — 6 shortcircuits the grid of V1B to ground when the function selector switch is in «AMP» position.

The output from the playback pre-amplifier is fed to the top of the volume control potentiometer R4 across the switches A16 — 17 and B1 — 2.

The muting switch is shortcircuiting the record/playback head in all positions of the operating lever except in normal forward drive.

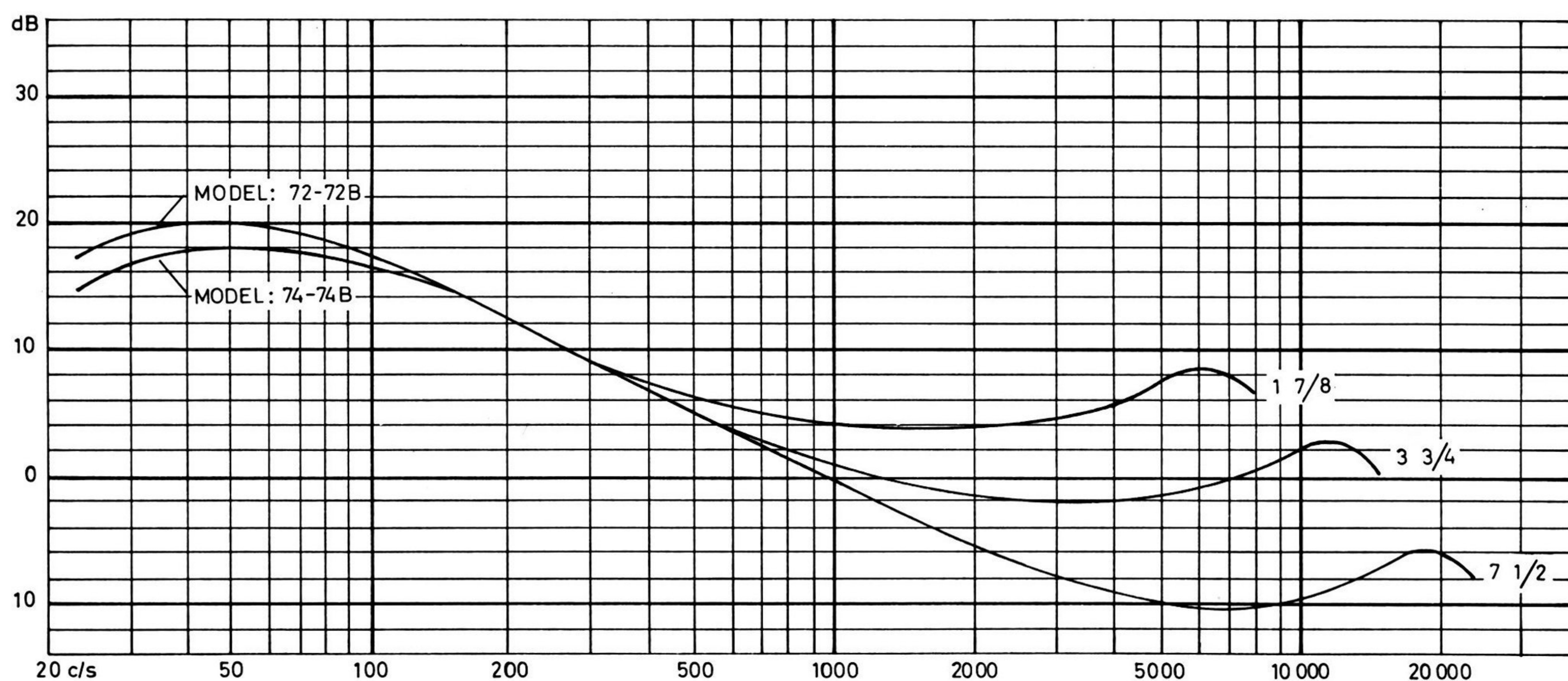

Fig. 43. The response curves for the playback pre-amplifier.

5.1.5 The record/power output amplifier, as power output amplifier

The schematic for the record/power output amplifier with all switches in record position is shown in fig. 40. The amplifier is a two stage combined record/power output amplifier using one section of the double triode ECC83 and the pentode EL84 (ref. note). The amplifier can be switched between record amplifier or power output amplifier by the function selector switch. Ref. chapter 5.1.3 for discussions of same as record amplifier.

The switch A9 — 8 is turned to position A9 — 7 and the record equalization circuit is grounded when the record/power output amplifier operates as a power output amplifier.

The switch A14 — 15 is moved to position A14 — 13

and shortcircuits the resistor R118. The programme will be reproduced at normal volume.

The negative feedback circuit from the secondary winding of the output transformer to the cathode of V8B increases the amplification approx. 4 dB at 50 c/s, when the BASS switch is in position «NORM». C206 and R210 will be connected in series with the feedback circuit when the BASS switch is moved to «BASS» position. The amplification will increase approx. 8 dB at 100 c/s.

The potentiometer R4 acts as the volume control.

Note: The tube ECL86 has been used on the models 74 and 72. It has been replaced by one section of the double triode ECC83 and the pentode EL84 on models 74B and 72B. For further information ref. chapter 5.8.

5.1.6 The playback pre-amplifier output stage

The schematic for the playback pre-amplifier output stage is shown below. Ref. fig. 44.

One section of the double triode ECC83 is used for the playback pre-amplifier output stage.

The input of the pre-amplifier output stage is connected across the resistors R401 and R402. C401 will increase the low frequency amplification approx. 3 dB. The potentiometer R455 in the playback pre-amplifier output stage ch. 2 is the balance adjustment. Ref. chapter 5.7.10 for the adjustment instruction.

A tape recorded to 5% distortion will give an output of 1 V when played back. The minimum load impedance is 100 K ohm.

The playback pre-amplifier output stage is operative only during playback.

Note: The playback pre-amplifier output stage is furnished on the models 74B and 72B only. Ref. chapter 5.8.

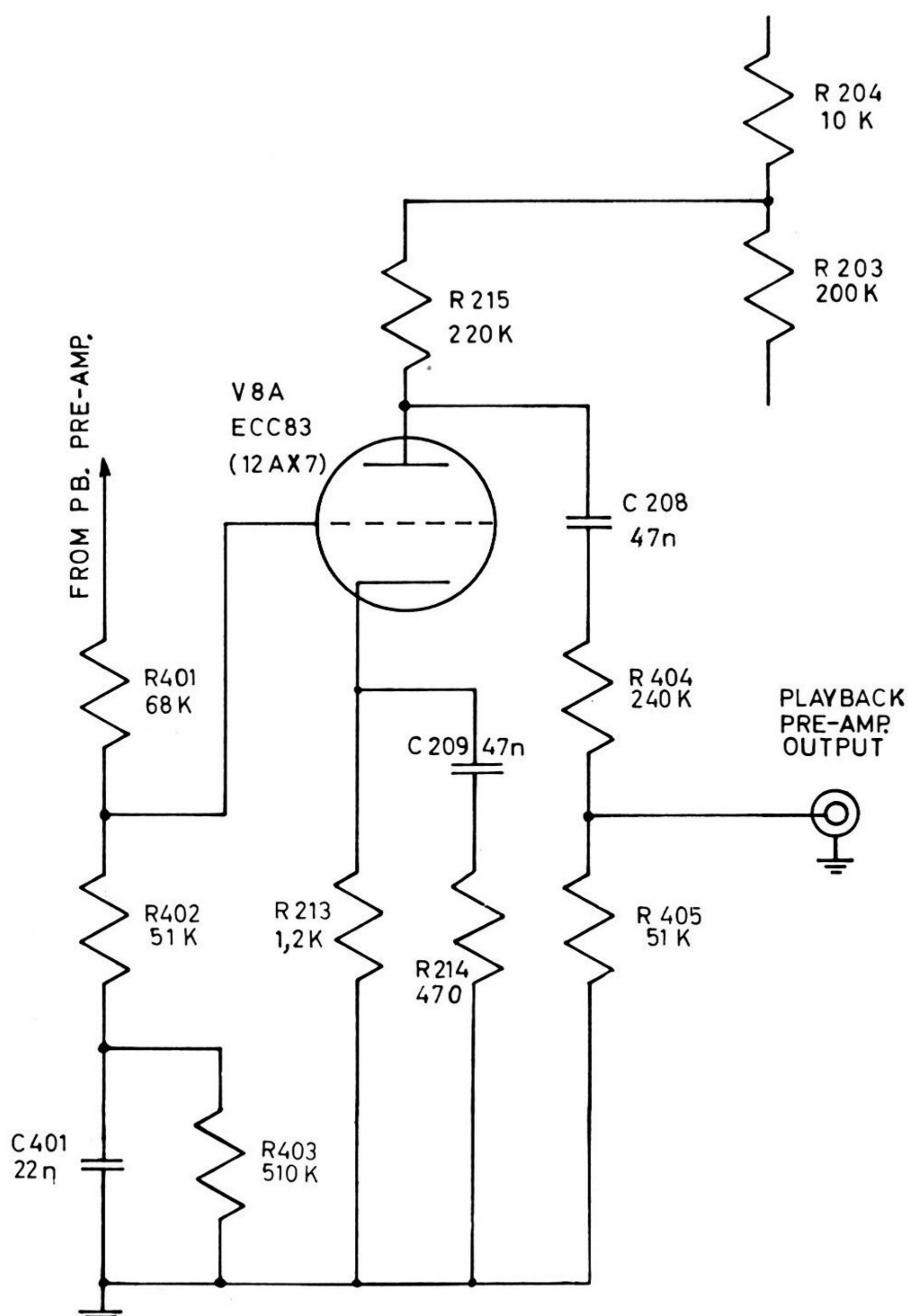

Fig. 44. The playback pre-amplifier output stage, schematic.

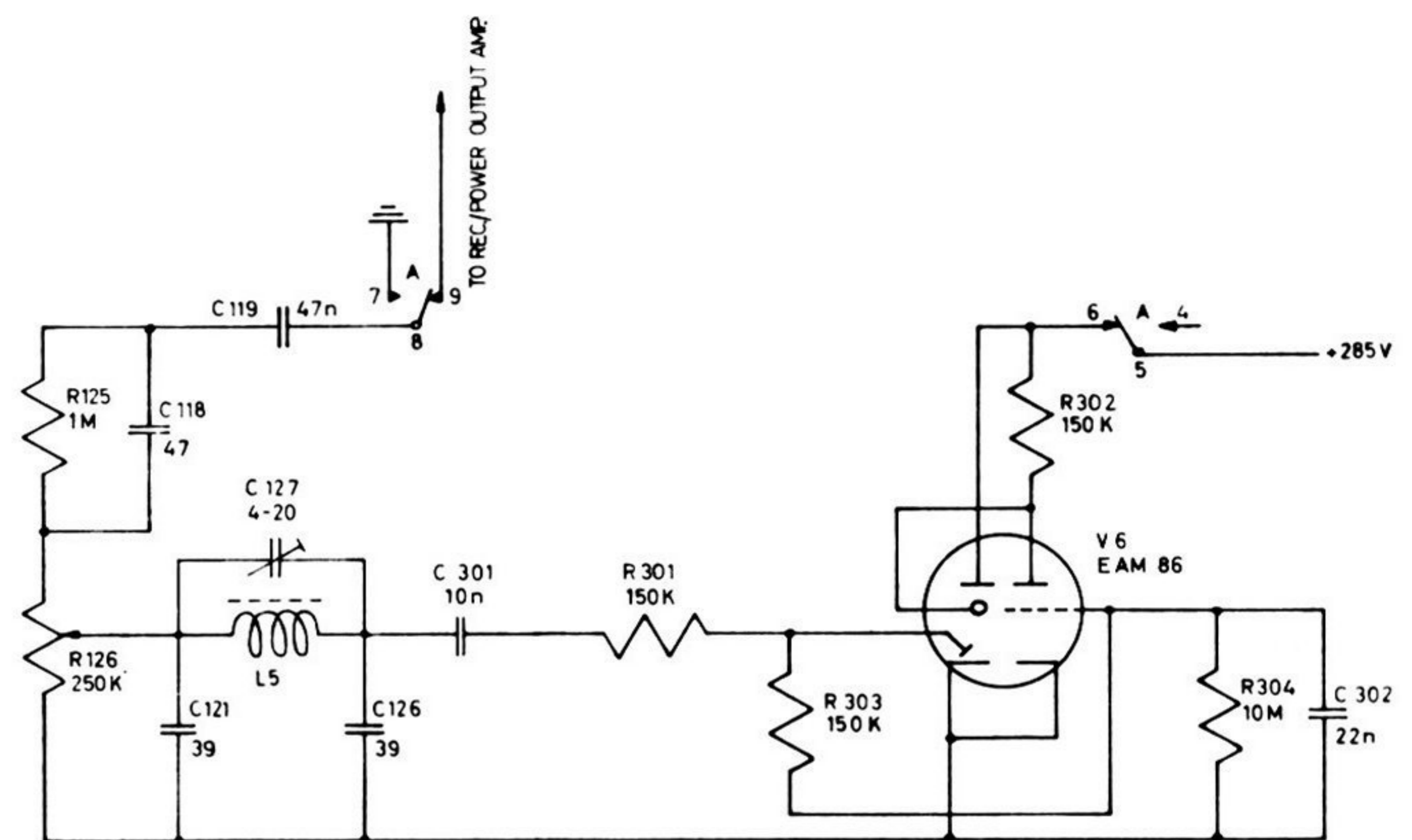

Fig. 45. The indicator circuit, schematic.

5.1.7 The record level indicator circuit

The schematic for the record level indicator circuit is shown above. Ref. fig. 45.

The EAM86 is a combined rectifier, triode, and indicator tube.

The input of the indicator circuit is connected to the center-tap of the potentiometer R126.

The signal is first rectified in the diode section of the EAM86. The DC signal is filtered by the damping circuit R304—C302 and connected to the grid of the amplifier section.

C121, C126, C127, and L5 acts as a bias trap. The filter is tuned to the oscillator frequency by C127.

capacitor C118 forms a frequency correction filter for the record level indicator.

The record level indicator is adjusted by R126 to close at a recording level corresponding to 5% distortion on a recorded tape (400 c/s), when played back.

5.1.8 The oscillator, bias and erase circuit

Ref. fig. 46.

The oscillator is of the push-pull type, using the double triode ECC82 (12AU7).

The DC supply is fed to the center-tap of the transformer L1.

The variation of the output voltage from the oscillator, caused by the variation of the oscillator load between monaural or stereo recording, is compensated by the resistor R135.

The oscillator frequency is set to 85.5 kc/s by adjusting the core of the transformer L1 — L2.

The bias current from the oscillator to the record heads is adjusted by the variable capacitors C120 and C170.

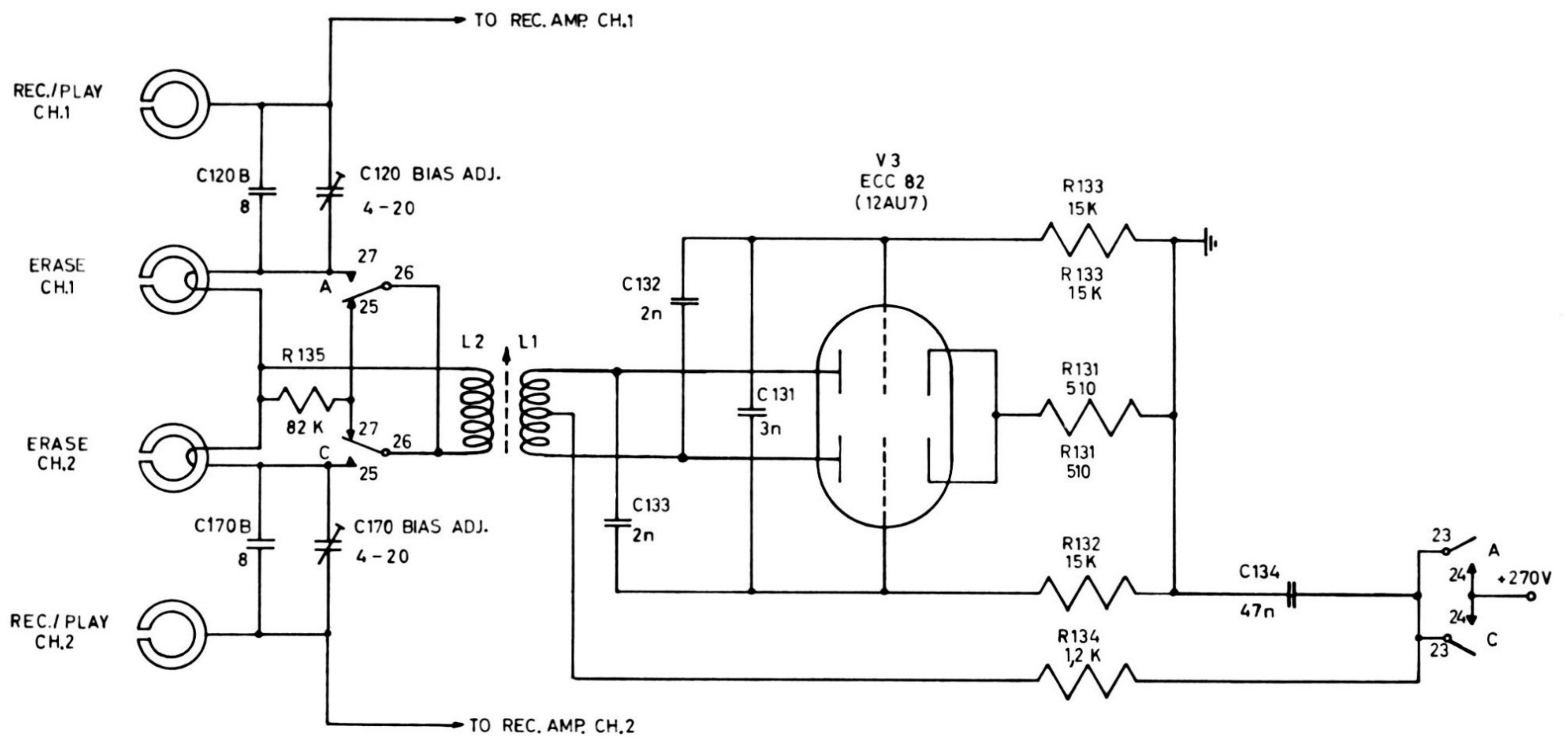

Fig. 46. The oscillator, erase, and bias circuit, schematic.

5.1.9. The power supply

Ref. fig. 47.

The transformer 11.1-280 is equipped with a mains voltage selector for 110 - 125 - 145 - 200 - 220 - 245 V, and can be used for 50 and 60 c/s.

Note: The mains voltage indicator plate at the bottom of the tape recorder will always show the mains voltage for which the transformer is connected. Ref. fig. 47.

The 245 volts secondary winding is connected to the rectifier B250 - C125 and furnishes all high voltages to the amplifiers, indicators and the oscillator.

The 165 volts secondary winding is connected to the motor.

The 6,3 volts secondary winding furnishes the AC filament voltage to all tubes and to the pilot lamp.

Note: The transformer 11.1-281 and the interlock system inserted in the mains cord is furnished on tape recorders sold in certain territories to conform with the U.L. approval.

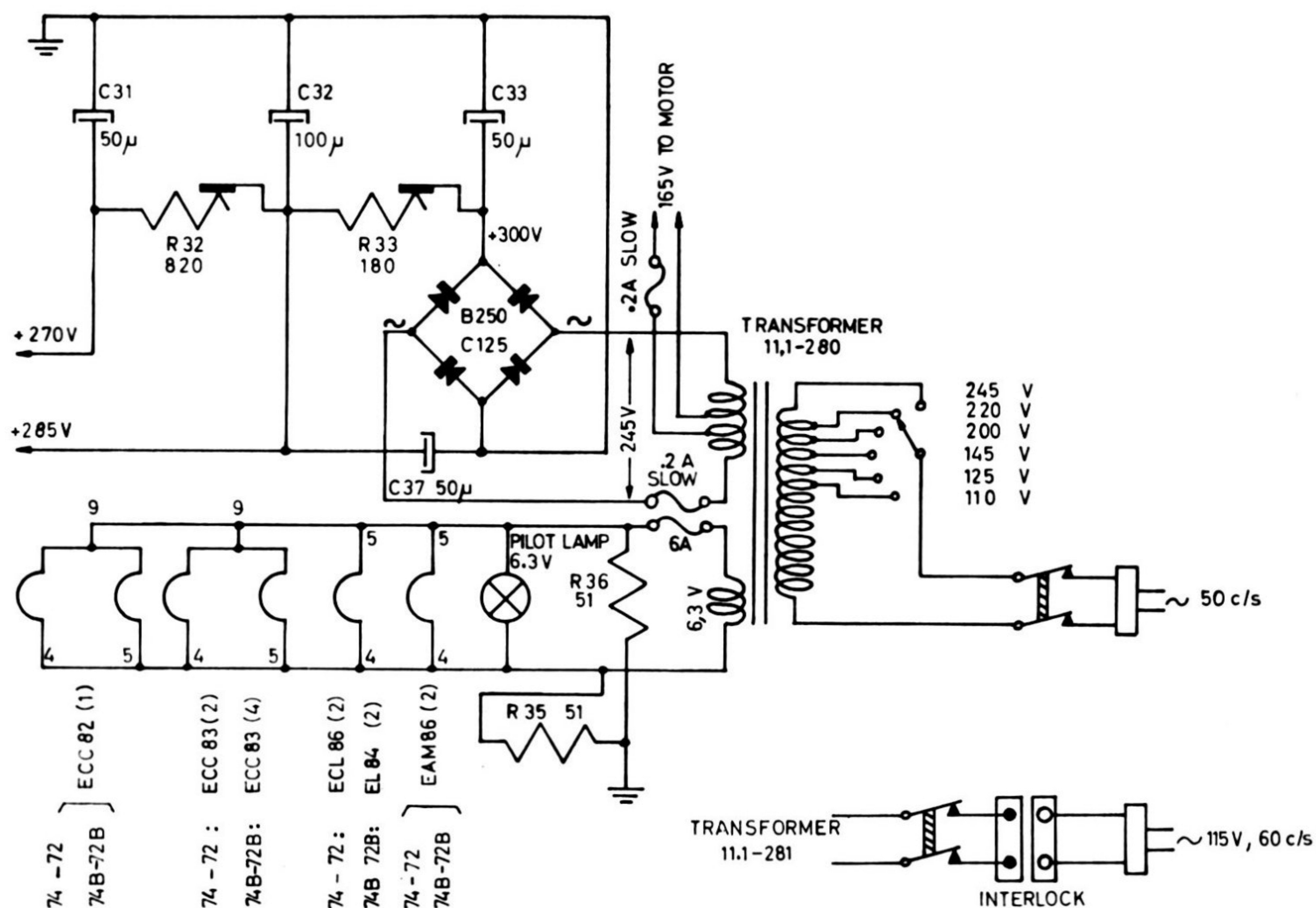

Fig. 47. The power supply, schematic.

5.2 THE SWITCHING SYSTEM

Ref. block diagram fig. 38.

5.2.1 The function selector switch

The function selector switch has two levers (ch. 1 and ch. 2) each of which has the following three positions. «RECORD», «PLAYBACK», and «AMP».

The two levers can be operated individually. An interlock system has been introduced between the operating lever and the two levers for the function selector switch to prevent unintentional erasure.

5.2.2 The speaker selector switch

The following speaker selector switches have been used in the models 74 – 72 and 74B – 72B.

Type 5703:

Fig. 48A shows the speaker selector switch in playback position.

The speaker selector switch type 5703 has been used on all models 74 and 72 below serial No. 640300.

The switch 5703 has three positions.

EXT: External speakers only. Ch. 1: left speaker, ch. 2: right speaker.

INT. + EXT: Internal and external speakers. Ch. 1: left speakers, ch. 2: right speakers.

INT: Internal speakers only. Ch. 1: left speaker, ch. 2: right speaker.

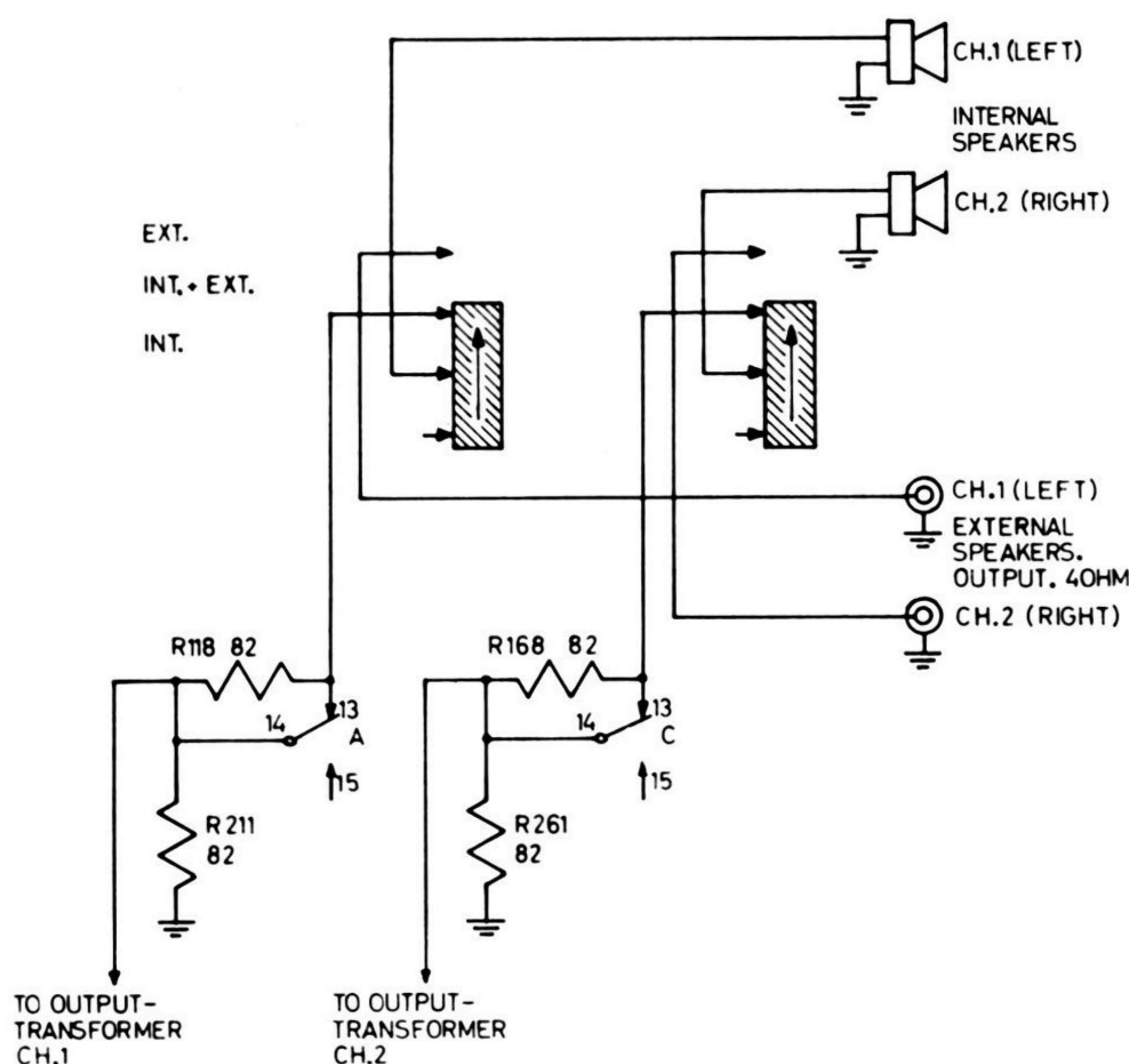

Fig. 48A. The speaker selector type 5703, schematic.

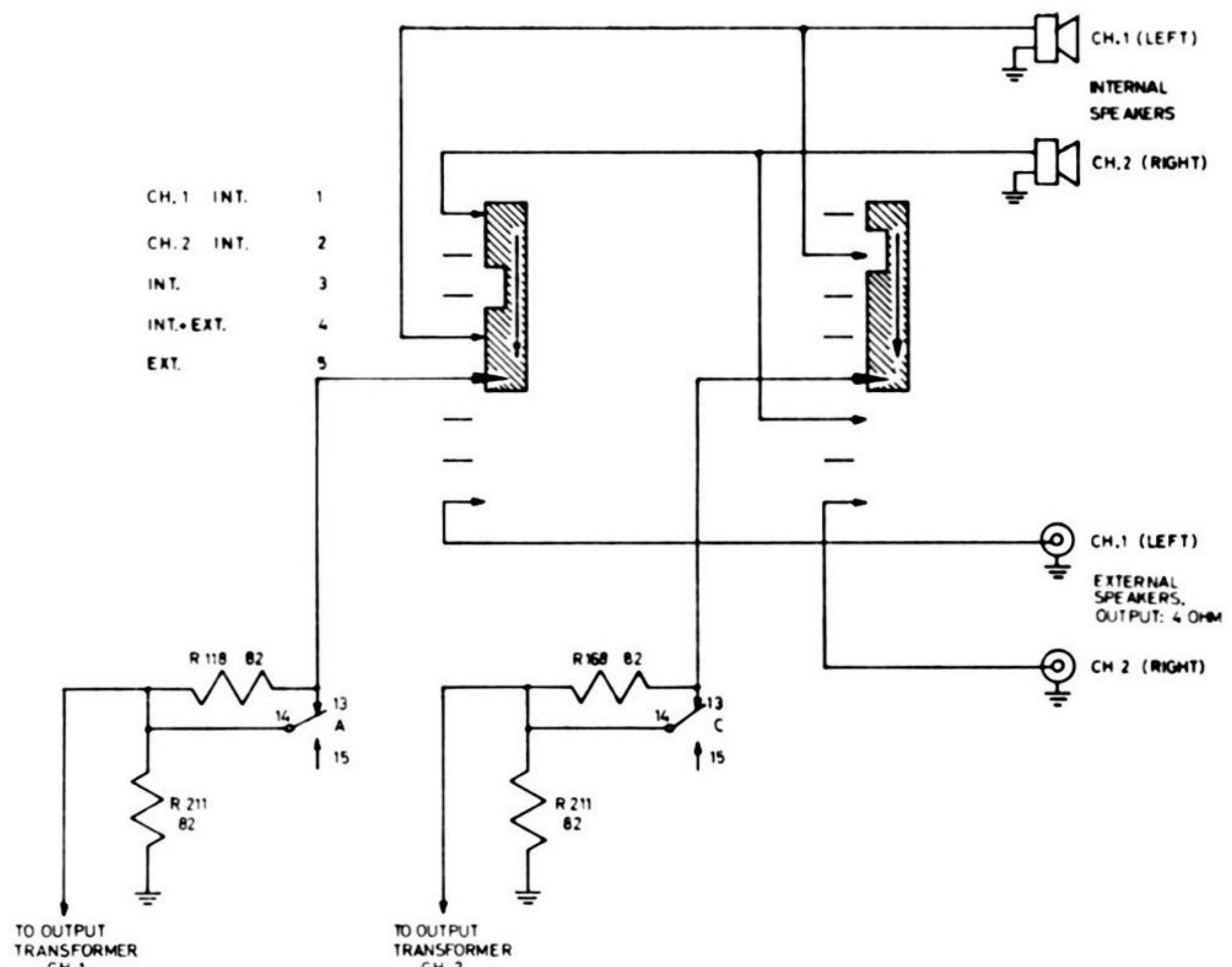

Fig. 48B. The speaker selector type 5439, schematic.

Type 5439:

Fig. 48B shows the speaker selector switch in playback position.

The speaker selector switch type 5439 has been used on all models 74 and 72 between serial No. 640301–711000.

The switch 5439 has five positions.

CH. 1 INT: The output from ch. 1 is connected to both internal speakers.

CH. 2 INT: The output from ch. 2 is connected to both internal speakers.

INT: Internal speakers only. Ch. 1: left speaker, ch. 2: right speaker.

INT. + EXT: Internal and external speakers. Ch. 1: left speakers, ch. 2: right speakers.

EXT: External speakers only. Ch. 1: left speaker, ch. 2: right speaker.

Type 6318

Fig. 48C shows the speaker selector switch in playback position.

The speaker selector switch type 6318 has been introduced on all models 74B and 72B from serial No. 711001.

The switch 6318 has five positions.

CH. 2 EXT. CH. 1 INT: The output from ch. 2 is connected to both external speakers. The output from ch. 1 is connected to both internal speakers.

CH. 1 EXT. CH. 2 INT: The output from ch. 1 is connected to both external speakers. The output from ch. 2 is connected to both internal speakers.

INT: Internal speakers only. Ch. 1: left speaker, ch. 2: right speaker.

EXT. + INT: External and internal speakers. Ch. 1: left speakers, ch. 2: right speakers.

EXT: External speakers only. Ch. 1: left speaker, ch. 2: right speaker.

Note: The resistors R118 (ch. 1) and R168 (ch. 2) are connected in series with the secondary winding of the output transformer, when the function selector switch is in «RECORD» position. The program that is being recorded will be monitored with a reduced output through the internal speaker or the external speaker terminals, depending upon the position of the speaker selector switch. R118 and R168 are shortcircuited by the contact A14 — 13 and C14 — 13 when the function selector switches are moved to «PLAYBACK» or «AMP» position.

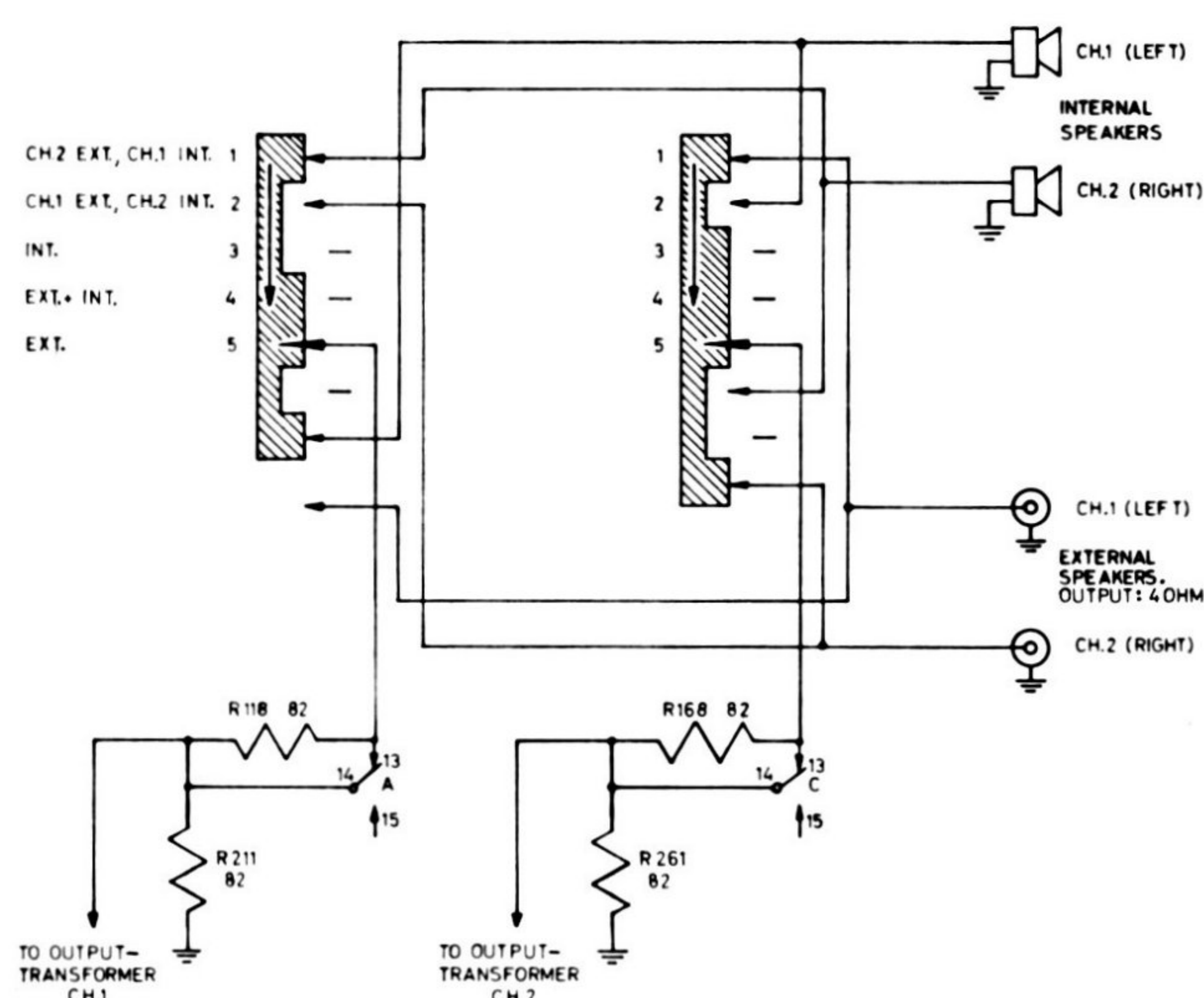

Fig. 48C. The speaker selector type 6318, schematic.

5.2.3 Monaural recording on ch. 1 or ch. 2

Ref. block diagram fig. 38.

We presume that we are recording on ch. 1 (upper track). The input signal is fed to the microphone jack ch. 1. The function selector switch ch. 1 is in pos. «RECORD» and the function selector switch ch. 2 is in pos. «AMP». The speaker switch is set to pos. «INT». The signal passes through the record pre-amplifier ch. 1 and the record/power output amplifier ch. 1 to the record head. The record/power output amplifier ch. 1 is operating as a recording amplifier. The record level indicator and the erase head ch. 1 are both activated.

The resistor R118 (82 ohm) is connected in series with the internal speaker ch. 1 and the recording signal will be monitored with a reduced output through this speaker.

The input of the record/power output amplifier ch. 2 is connected to the output from the record pre-amplifier ch. 1. The record/power output amplifier ch. 2 is operating as a power output amplifier and is connected to the internal speaker ch. 2. We are monitoring the recording signal through the internal speaker ch. 2. The output gain is controlled by the volume control ch. 2.

The procedure for monaural recording on ch. 2 is exactly the same as above except that the function selector switch ch. 1 is set to «AMP» pos. and the function selector switch ch. 2 is set to pos. «RECORD».

5.2.4 Mixing during monaural recording

Ref. block diagram fig. 38.

We presume that the mixed programme (programme 1 and 2) is to be recorded on channel 1 (upper track). Programme 1 is connected to the line input ch. 1 and programme 2 is connected to the line input ch. 2.

The outputs from the two record pre-amplifiers are connected together when the function selector switch ch. 1 is set to pos. «RECORD» and the function selector switch ch. 2 is set to pos. «AMP». The two programmes are mixed and fed to the record/power output amplifier and the record head ch. 1. The record gain is controlled by the volume control ch. 1 and the input of the record/power output amplifier ch. 2 is connected parallel to the input of the record/power output amplifier ch. 1. The record/power output amplifier ch. 2 is operating as a power output amplifier and is connected to the internal speaker ch. 2 when the speaker switch is set to pos. «INT».

The mixed programme will be monitored through both internal speakers with a reduced output through the speaker ch. 1. The output gain of the internal speaker ch. 2 is controlled by the volume control ch. 2.

The procedure for recording the mixed programme on ch. 2 is analogical as outlined above, with the function selector switch ch. 1 in pos. «AMP» and the function selector switch ch. 2 in pos. «RECORD».

Note: The line inputs are disconnected when the microphone plug is inserted.

5.2.5 Stereo recording

Ref. block diagram fig. 38.

The two function selector switches (ch. 1 and ch. 2) are set to «RECORD» position and the speaker selector switch to «INT».

The two signals (ch. 1 and ch. 2) pass through each record pre-amplifier and record/power output amplifier to the record heads.

The connection between the outputs from the record pre-amplifiers and the connection between the inputs of the record/power output amplifiers are disconnected in stereo recording.

The internal speakers (ch. 1 and ch. 2) are connected in series with R118 and R168 to the output of the record/power amplifiers. We are monitoring the recording signal with a reduced output.

5.2.6 Monaural playback, channel 1 or 2

Ref. block diagram fig. 38.

We presume that the recorded programme is played back from ch. 1.

The function selector switch ch. 1 is set to pos. «PLAYBACK» and the function selector switch ch. 2 is set to pos. «AMP». The speaker switch is in pos. «INT».

The output from the playback pre-amplifier ch. 1 is connected to the input of both record/power output amplifiers and to the input of the playback pre-amplifier output stage ch. 1. The record/power output amplifiers are operating as power output amplifiers.

The programme will be reproduced through both internal speakers, and through the output from the playback pre-amplifier output stage ch. 1.

The procedure for playback from ch. 2 is exactly the same as above except that the function selector switch ch. 1 is set to «AMP» pos. and the function selector switch ch. 2 is set to pos. «PLAYBACK».

5.2.7 Stereo playback

Ref. block diagram fig. 38.

Both function selector switches (ch. 1 and ch. 2) are set to position «PLAYBACK», and the speaker switch is set to position «INT». The connection between the inputs of the record/power output amplifiers is disconnected.

The signals will pass each playback pre-amplifier and record/power output amplifier (operating as power output amplifier). The stereo programme will be played back through both internal speakers and through both playback pre-amplifier output stages.

5.2.8 Public address (stereo amplifier)

Ref. block diagram fig. 38.

The function selector switches ch. 1 and ch. 2 are set to position «AMP». The signals pass each record pre-amplifier and record/power output amplifier (operating as power output amplifiers) and are fed to the speakers. The connection between the outputs from the record/power output amplifiers are disconnected. The output gain is controlled by the volume controls (upper knob ch. 1, lower knob ch. 2).

5.2.9 Add a track

Ref. block diagram fig. 38.

The «add a track» recording is a technique of playing

back a pre-recorded programme from one channel, and record another programme on the other channel at the same time. Both programmes will be heard simultaneously when the tape is played back in stereo. We presume that the pre-recorded programme is recorded on ch. 1. The function selector switch ch. 1 is set to pos. «PLAYBACK», and the speaker selector switch is set to pos. «INT». The signal will pass the playback pre-amplifier and the record/power output amplifier ch. 1, (operating as a power output amplifier) and fed to the internal speaker ch. 1. The playback pre-amplifier output stage ch. 1 is operative.

The recording is made on ch. 2 and the recording signal may be connected to either of the input terminals ch. 1, ch. 2, or both.

The function selector switch ch. 2 is set to «RECORD» pos. The outputs from the record amplifiers are connected together and the signal passes the record/power output amplifier ch. 2 (operating as a recording amplifier), and is fed to the record head ch. 2.

The recording signal is monitored through the internal speaker ch. 2 with a reduced output.

The «add a track» recording used for language teaching

Language teaching is a typical example of the use of «add a track» recording, the lesson (master track) is pre-recorded on the tape and the student can playback, listen to the lesson, monitor and record his own exercises. The playback must be in stereo, and the master track is then reproduced from one channel, and the student's track from the other. The playback can be heard in the two loudspeakers or mixed through the center channel in the earphones. The student is able to record and erase his own exercise at will, with no interference to the master track.

Procedure

We presume that the pre-recorded master programme is recorded on ch. 1 (upper track). Set the function selector switch ch. 1 to «PLAYBACK» position, and the speaker selector switch to «EXT». The master's voice will be heard in the earphones, which are connected to the center channel output, when the tape recorder is started. The level is adjusted with the upper volume control knob. The recording of the student's voice is made on ch. 2 (lower track). Set the function selector switch ch. 2 to «RECORD» position simultaneously with the operating lever being moved to normal forward drive position. The level of the recording is adjusted with the lower volume control knob. The student will monitor his own voice in the earphones with the volume determined by the recording level.

Rewind the recorded tape and play it back with both function selector levers in pos. «PLAYBACK» (stereo playback). The levels from the two channels can be set individually with the volume control knobs.

The operation will be analogical if the master programme is recorded on ch. 2 (lower track). It is also possible to use the internal loudspeakers, at a limited level, for language studying groups. The feedback between the internal loudspeakers and the microphone will decide the maximum level applicable.

5.2.10 Sound on sound

Ref. block diagram fig. 38.

Sound on sound recording is a technique where a programme is played back from one track and simultaneously a second programme is added, the two programmes being recorded combined on another track. (One superimposed on the other.) Consequently the playback of the combined programme must be in mono. In «add a track» where two programmes are on two separate tracks the playback must be in stereo. In «sound on sound» one has the possibility of building up a complete programme from separate sources, however the sound quality may be slightly reduced by many re-recordings.

The models 74 – 72 and 74B – 72B have limited possibilities for sound on sound recordings. These tape-recorders are equipped with combined record and playback heads, and there will always be some magnetic coupling between the head which is recording and the head playing back. When the sound on sound recording is made, the output from the playback channel is connected to the input of the recording channel. If the loop amplification from the playback head to the recording head is too great the feedback between the two heads will cause instability and oscillations. Sound on sound recordings can only be completely satisfactory on a taperecorder with three heads, i.e. Tandberg Tape Recorder Models 64 and 62. If in spite of this, you wish to record sound on sound on the models 74 – 72, 74B – 72B, you must first find out where the oscillation limit is and keep your volume controls below this limit.

Preferred instruction for sound on sound recording

We presume that the pre-recorded programme is recorded on ch. 1. The power output terminal ch. 1 is

connected to the line input ch. 1 by a strap. The speaker selector switch is set to «EXT» pos. The microphone is connected to mic. 2 input. The function selector switch ch. 2 is set to «RECORD» pos. and the operating lever is moved to normal forward drive. The function selector switch ch. 1 is set to «PLAYBACK» pos.

The volume control ch. 2 (lower knob) is adjusted to maximum recording level from the microphone with the start-stop lever in «STOP» pos. and with the volume control ch. 1 set to min. This is a test recording and the tape is not moving. The recording level for ch. 2 is now pre-set and should not be touched during the actual recording.

Move the start-stop lever to the left position and start the recording.

Increase the setting of the volume control ch. 1 (upper knob) up to a point just below complete closing of the record level indicator ch. 2 (the point of instability).

The pre-recorded programme on ch. 1 is played back through the playback pre-amplifier and the record/power output amplifier ch. 1, and is fed to the line input ch.1 by the strap. (The record/power output amplifier ch. 1 is operating as a power output amplifier.)

The two outputs from the record pre-amplifiers are interconnected. The pre-recorded programme and the programme from the microphone through the record pre-amplifier ch. 2 are both fed to the input of the record/power output amplifier and the record head ch. 2. (The record/power output amplifier ch. 2 is operating as a recording amplifier.)

Rewind the tape when the recording is completed, and play back the sound on sound recording with the function selector switch ch. 2 in «PLAYBACK» pos. (monaural playback ch. 2).

5.3 HEAD ALIGNMENT AND TRACK CONTROL WITH TANDBERG TEST TAPES

5.3.1 The models 74 and 74B

1. Demagnetize the heads and the adjacent parts before aligning the heads.
2. Move the operating lever to normal forward drive with a tight tape inserted. Align the vertical position of the adjustable tape guide (79.31) until the tape runs equidistant from the flanges of the tape guide. Ref. fig. 10.
3. Move the operating lever to normal forward drive with a tight tape inserted. Align the vertical position of the adjustable tape guide (79.31) until the tape runs equidistant from the flanges of the tape guide. Ref. fig. 10.
4. Play back the test tape No. 1. This is a full track pre-recorded tape with 1000 c/s recorded at 7½ i.p.s. tape speed. The record level of the exact area corresponding to track 3 is reduced 30 dB. Adjust the height of the combined record/playback head until minimum output is obtained on a VTVM from track 3.
5. Play back the test tape No. 2. This is a full track pre-recorded tape with 10 000 c/s at 7½ i.p.s. tape speed. Adjust the azimuth position of the combined record/playback head until maximum reading is obtained on both output meters. Ref. chapter 5.4.3 for lateral adjustment.

6. Play back the test tape No. 3. This is a full track pre-recorded tape with the following frequencies: 250 - 10 000 - 5000 - 1000 - 100 - 50 - 250 c/s recorded at 7½ i.p.s. tape speed. The tape conforms with the N.A.B. standards. The output tolerance is ± 2 dB for all frequencies. The difference in level between the two channels should be less than 3 dB at any frequency.
7. The erase head is set in a preliminary position where approx. 0,25 mm (.01") of the ferrite core for the upper track is visible above the tape. Insert the test tape No. 9, and record a 1000 c/s signal from the generator on channel 2 (track 3) at maximum recording level. Dip the tape into the Magna-See solution and check that the re-recorded track is in center of the erased area. Adjust the height position of the erase head if necessary. Make sure that the erase head does not erase any part of the neighbour track. Ref. chapter 5.4.4 for lateral adjustment.
8. Ref. chapters 5.7.2 and 5.7.3 for setting of the bias and the recording current.

5.3.2 The models 72 and 72B

All the alignments specified in chapter 5.3.1 are valid for the models 72 and 72B with the exception of the paragraphs 4 and 7. Paragraph 4 is superseded by the instruction 5.6.2, page 34 and paragraph 7 is superseded by the instruction 5.6.1, page 34.

5.4 HEAD ALIGNMENT WITHOUT TANDBERG TEST TAPES

5.4.1 Demagnetizing

Demagnetize the heads and adjacent parts before aligning the heads.

5.4.2 The adjustable tape guides

Ref. fig. 10.

The adjustable tape guide 79.15:

Move the operating lever to normal forward drive with a tight tape inserted. Align the vertical position of the adjustable tape guide (79.15) until the tape runs equidistant from the flanges of the tape guide.

The adjustable tape guide 79.31:

Move the operating lever to normal forward drive with a tight tape inserted. Align the vertical position of the adjustable tape guide (79.31) until the tape runs equidistant from the flanges of the tape guide.

5.4.3 The record/playback head

The height alignment:

The height of the record/playback head is aligned by the height adjustment screws, ref. fig. 10. The upper edge of the tape shall run flush with the upper part of the airgap for ch. 1. Ref. chapters 5.5.1 and 5.6.2, for track control of the record/playback head.

The azimuth alignment:

Play back a standard azimuth alignment tape with a VTVM connected to each external speaker output terminal. Set the speaker switch to position «EXT». Adjust the position of the record/playback head by the azimuth adjustment screw, ref. fig. 10, until maximum reading is obtained on the output meters.

The lateral alignment:

Pull the pressure pad away from the erasure head when the standard azimuth alignment tape is being played back. The output level should not decrease more than 3 dB. Adjust the lateral position of the record/playback head, if necessary, by turning the head mounting plate.

5.4.4 The erase head

The height alignment:

The height of the erase head is aligned by the height adjustment screws. Ref. fig. 10. Approx. 0.25 mm (.01") of the ferrite core for the upper track of the erase head, should be visible above the tape. Ref. chapters 5.5.2 and 5.6.1, for track control of the erase head.

The azimuth alignment:

Align the azimuth position of the erase head by the azimuth adjustment screw. The erase head should be parallel to the upper mounting plate. The azimuth position of the erase head is not critical.

The lateral alignment:

Turn the head mounting plate for the erase head until the front of the head is parallel to the felt pressure pad.

5.5 TRACK CONTROL, MODELS 74 AND 74B WITHOUT TANDBERG TEST TAPES

5.5.1 The record/playback head

Record a 1000 c/s signal in stereo from a generator at maximum recording level, on track 1 and 3 (both function selector switches in «RECORD» position), for approx. 5 seconds. Turn the tape around and make a similar recording on track 4 and 2. Cut the tape and dip it into a mixture of iron powder and alcohol (Magna-See) to make the recording visible. The spaces between the recorded tracks should be distributed equidistant across the tape. Readjust the height position, if necessary, and recheck the azimuth alignment.

5.5.2 The erase head

Insert a full-track pre-recorded tape and record a 1000 c/s signal from a generator at maximum recording level on track 3 (the function selector switch ch. 2 in «RECORD» position). Cut the tape and dip it into the Magna-See solution. Check that the re-recorded track is in the center of the erased area. Adjust the vertical position of the erase head, if necessary.

5.6 TRACK CONTROL, MODELS 72 AND 72B WITHOUT TANDBERG TEST TAPES

5.6.1 The erase head

The height of the erase head is aligned by the height adjustment screws. Ref. fig. 10. The tape shall run equidistant from the upper and the lower edge of the ferrite core.

For the azimuth and lateral alignments ref. chapter 5.4.4.

5.6.2 The record/playback head

The height of the record/playback head is aligned by the height adjustment screws ref. fig. 10. Record a 1000 c/s signal in stereo (both function selector switches are set to «RECORD» pos.), at maximum recording level on a full track pre-recorded tape. Dip the tape in the Magna-See solution and check that the tracks are distributed symmetrical across the tape, and that the pre-recorded zone remains in the center of the erased zone. Readjust the erase and record heads, if necessary.

For the azimuth and the lateral alignment ref. chapter 5.4.3.

5.7 ELECTRICAL ADJUSTMENTS

5.7.1 Adjustment of the oscillator and erase circuits

Ref. fig. 49 and 50.

Set the two function selector switches to «RECORD» position and move the operating lever to normal forward drive. Use a calibrated grid-dip meter and adjust the core in the oscillator coil L1 — L2 to a frequency of 85.5 kc/s. The voltage across the erase head halves should be 180—210 volts.

Move the function selector switch ch. 1 to position «PLAYBACK» (monaural recording ch. 1). The voltage across the upper erase head should not change more than $\pm 5\%$, and the frequency should not drop more than approx. 5% .

Check the erase voltage across the lower erase head and the oscillator frequency, as outlined above, with the function selector switch ch. 2 in «RECORD» position (monaural recording ch. 2).

5.7.2 Bias adjustment

Ref. fig. 50.

Insert a 100 ohm resistor in series with each record/playback head halves to ground (center terminal on the mounting strip for the head). Connect a VTVM across each resistor and set both function selector switches to record position, with the volume control to minimum. Adjust C120 (ch. 1) and C170 (ch. 2) for a reading of 70 mV on each VTVM.

5.7.3 Adjustment of the recording current and the indicators

Ref. fig. 49.

Set both function selector switches to «RECORD» posi-

tion and move the operating lever to normal forward drive at $7\frac{1}{2}$ i.p.s. tape speed. The signal generator is connected to both input terminals and tuned to 400 c/s. Insert a 100 ohm resistor in series with each record/playback head halves to ground (red wire). Connect a VTVM across each resistor and remove the oscillator tube V3. Set the volume controls (ch. 1 and ch. 2) to position 3 and increase the output level from the signal generator until the reading on the vacuum tube volt meters shows 12 mV. Adjust R126 (ch. 1) and R176 (ch. 2) until the electronic beam indicators are closing.

Check that the distortion is 4–6% on a signal recorded at maximum level when played back. Readjust R126 and R176, if necessary.

Disconnect the two 100 ohms resistors and set the speed selector to $1\frac{7}{8}$ ". Move the function selector switch ch. 1 to «RECORD» pos. and turn down both volume controls to zero. Adjust C127 until minimum indication is obtained on the electronic beam indicator ch. 1.

Repeat the adjustment for ch. 2 with the function selector ch. 2 in «RECORD» position.

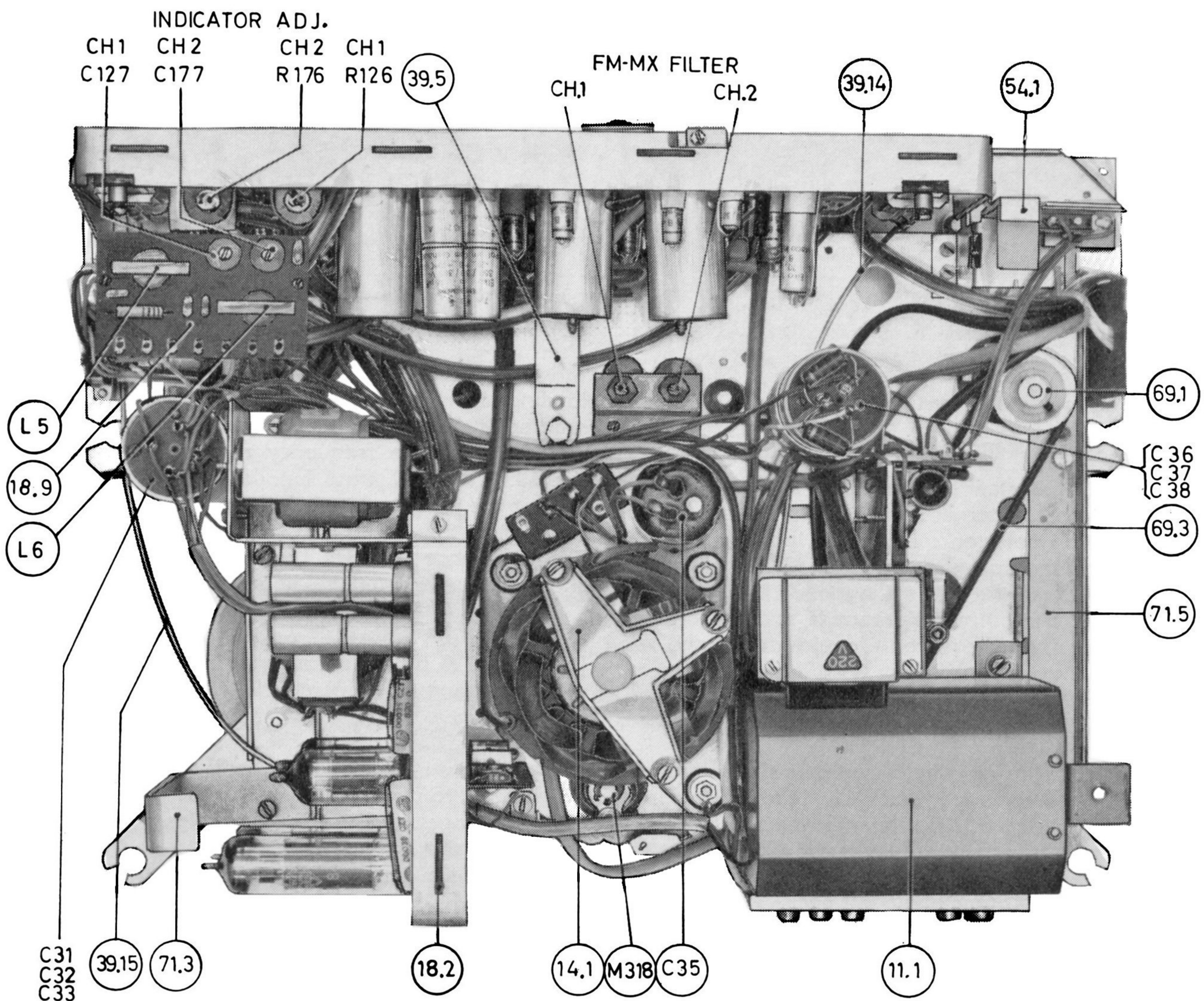

Fig. 49. Bottom view of the tape recorder.

5.7.4 Adjustment of the FM-multiplex filters

Ref. fig. 49.

Feed a 19 000 c/s signal to both line input terminals and set the function selector switches ch. 1 and ch. 2 to «AMP» position (stereo amplifier). Turn the «INPUT LEVEL SET» potentiometers R501 and R551 to minimum (counter clockwise). Connect a VTVM to both external speaker terminals and set the speaker switch to «EXT» position. Adjust the core of L3 (ch. 1) and the core of L4 (ch. 2) until minimum readings are obtained on the output meters.

5.7.5 Adjustment of the input level set potentiometers

Ref. fig. 2 and 3.

The input impedance of the two line input terminals is adjustable between .1—5 Mohm.

Connect the external equipment (pre-amplifier or tuner ect.) to the line input terminals, and make a stereo recording with the function selector switches to position «RECORD», and both volume controls to position 3. Adjust the «INPUT LEVEL SET» R501 (ch. 1) and R551 (ch. 2) until the electronic beam indicators are closing.

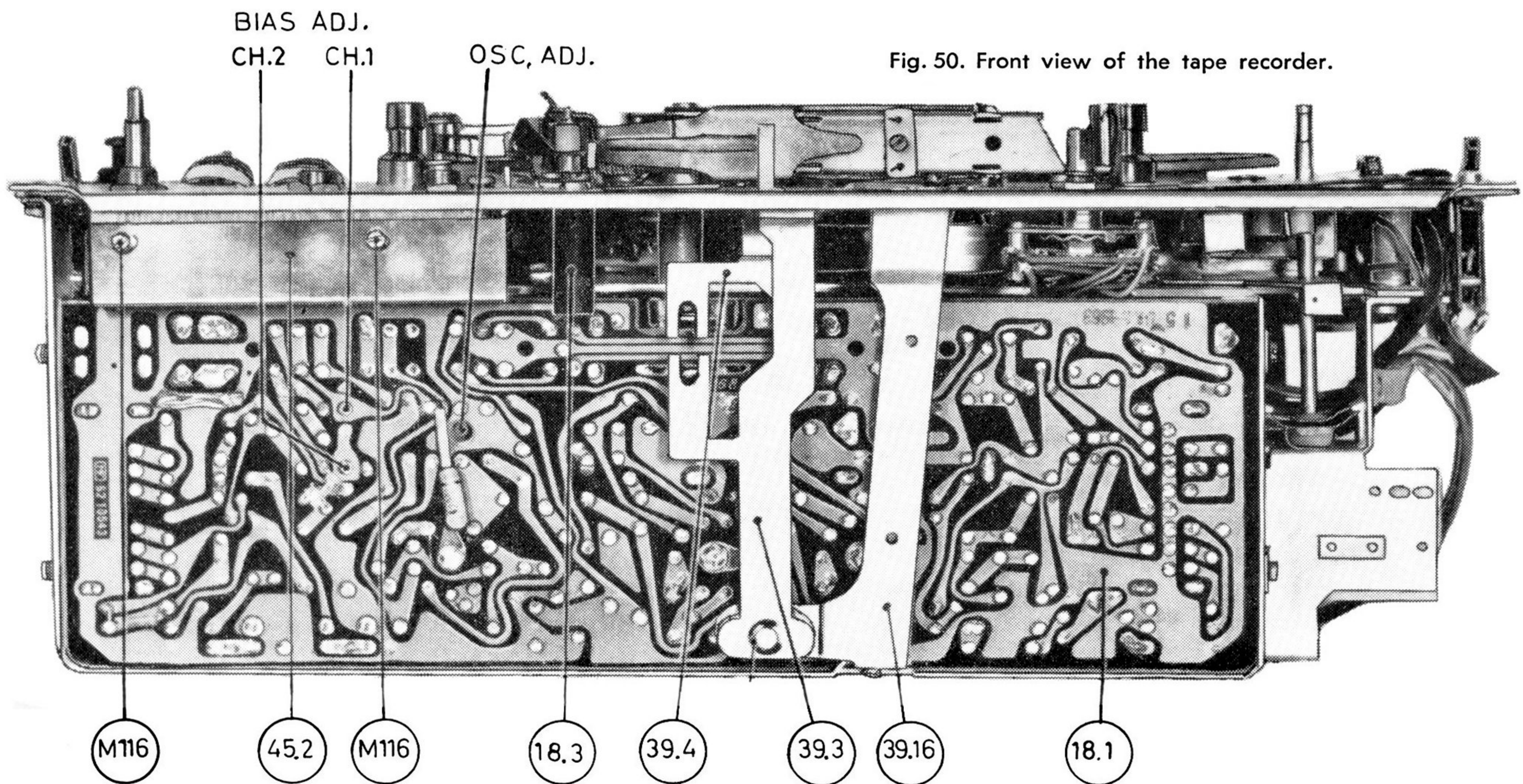

Fig. 50. Front view of the tape recorder.

5.7.6 Playback amplifier test

With the N.A.B. standard frequency tape

Insert the N.A.B. standard frequency tape and connect a VTVM to each external speaker output terminal. Set both function selector switches to position «PLAYBACK», and the speaker switch to «EXT». Play back the tape and use the 250 c/s signal as the 0 dB reference point. The output tolerance is ± 2.5 dB for all frequencies. The difference in level between the two channels should be maximum 3 dB at any frequency.

Without the N.A.B. standard frequency tape

Insert a 100 ohm resistor in series with the record/playback head for upper track (ch. 1) to ground (yellow wire). Connect a signal generator across the resistor and set the operating lever to normal forward drive, with the function selector switches to «PLAYBACK» position. Connect a VTVM to the POWER AMP. OUTPUT ch. 1, and set the speaker switch to «EXT». Tune the signal generator to 1000 c/s and set the volume control ch. 1 (upper knob) to maximum. Increase the level from the signal generator until the reading on the output meter is approx. 1.5 V. (To prevent over-

loading, do not increase the level above 2 volts). The reading is the 0 dB reference point, at $7\frac{1}{2}$ i.p.s. tape speed. Check the frequency response according to fig. 43.

Repeat the measurements for the lower track (ch. 2). The output tolerance is ± 2.5 dB for all frequencies. The difference in level between the two channels should be maximum 3 dB at any frequency.

5.7.7 Record amplifier test

Insert a 1000 ohm resistor in series with the record/playback head for upper track (ch. 1) to ground (red wire). Remove the oscillator tube V3 and connect a VTVM across the resistor. The signal generator is connected to the line input ch. 1. Set the function selector switch ch. 1 to record position and the operating lever to normal forward drive. Tune the signal generator to 1000 c/s and turn down the output from the generator 20 dB below maximum recording level. The reading on the VTVM is the 0 dB reference point. Check the frequency response according to fig. 41.

Repeat the measurement for the lower track (ch. 2). The output tolerance is ± 2.5 dB for all frequencies. The difference in level between the two channels should be less than 3 dB at any frequency.

5.7.8 Total record and playback response

Set both function selector switches to «RECORD» pos. (stereo recording), and insert a good quality tape. The signal generator is connected to both line inputs and tuned to 1000 c/s.

Turn down the output level from the generator 20 dB below maximum recording level and record the frequency spectrum from 40–16 000 c/s at 7½ i.p.s. tape speed.

Rewind the tape and play it back with a VTVM connected to both external speaker output terminals with the speaker switch in position «EXT» and both function selector switches in position «PLAYBACK». Check the frequency response for all speeds according to the specification.

7½ i.p.s.: 40–16 000 c/c ± 2 dB
 3¾ i.p.s.: 60–10 000 c/s ± 2 dB
 1⅞ i.p.s.: 80– 5 000 c/s ± 2 dB

The difference in level between the two channels should be less than 3 dB at any frequency.

Increase the bias slightly if the treble response is too high, by adjusting C120 (ch. 1) and C170 (ch. 2).

Decrease the bias slightly if the treble response is too low, by adjusting C120 (ch. 1) and C170 (ch. 2).

Note: Do not decrease the bias current below 60 µA. Recheck the distortion according to chapter 5.7.3, if the bias has been reduced.

5.7.9 Speed test

Insert a 1144 cm (450") marked tape section, and run it through the tape recorder with the operating lever in normal forward drive. The time for the tape section to pass by the record head should be:

7½ i.p.s.: 1 min.
 3¾ i.p.s.: 2 min.
 1⅞ i.p.s.: 4 min.

The speed tolerance should be ± 2 % at all speeds.

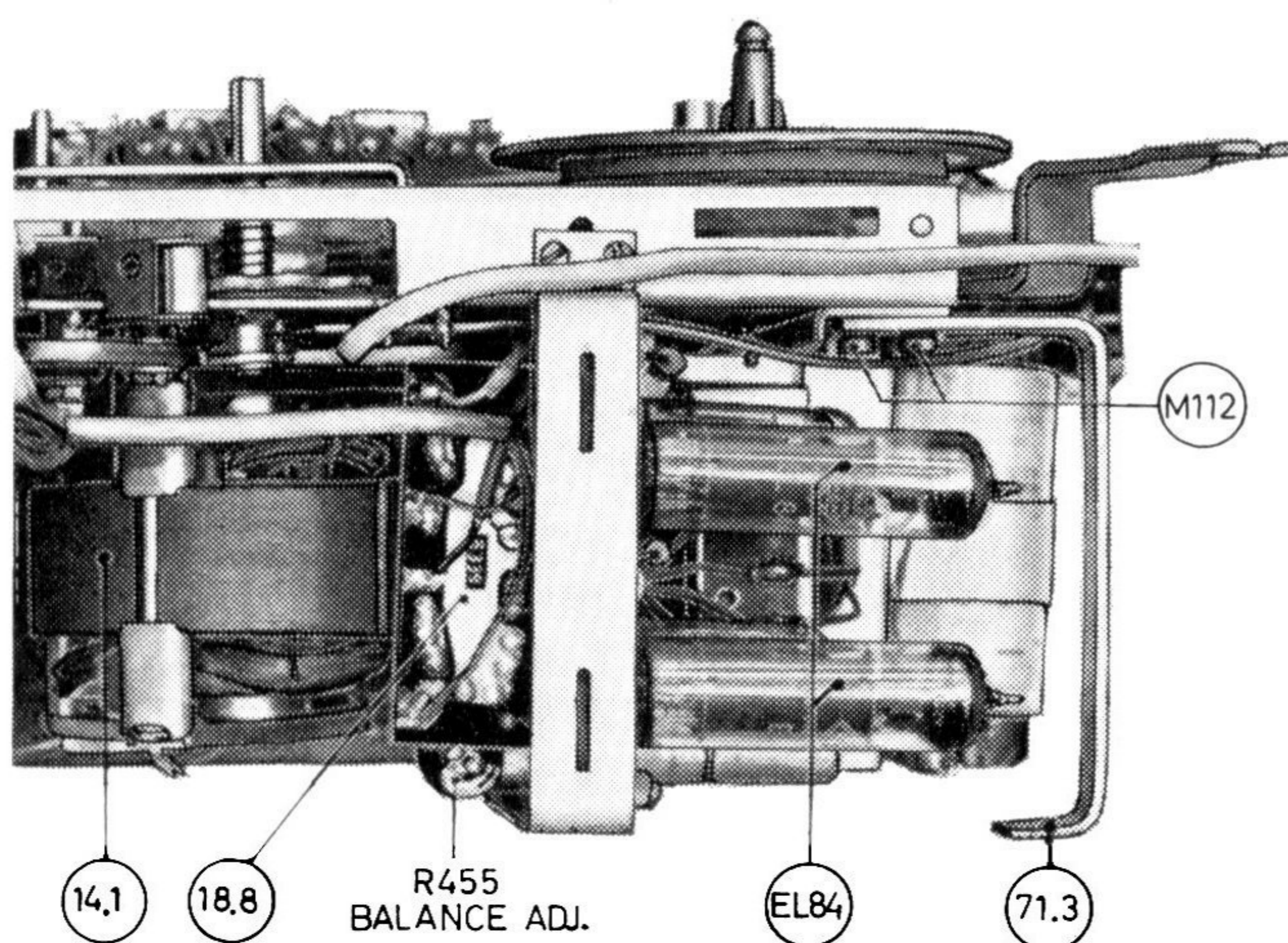

Fig. 51. Rear view of the tape recorder with the position of the balance control.

5.7.10 Adjustment of the balance control

Ref. fig. 51.

Insert a full-track pre-recorded tape with 250 c/s (Tandberg test tape No. 3), and set both function selector switches to «PLAYBACK» position. Connect a VTVM to each playback pre-amplifier output terminal and move the operating lever to normal forward drive (stereo playback). Adjust the potentiometer R455 (ch. 2) until the output levels are equal.

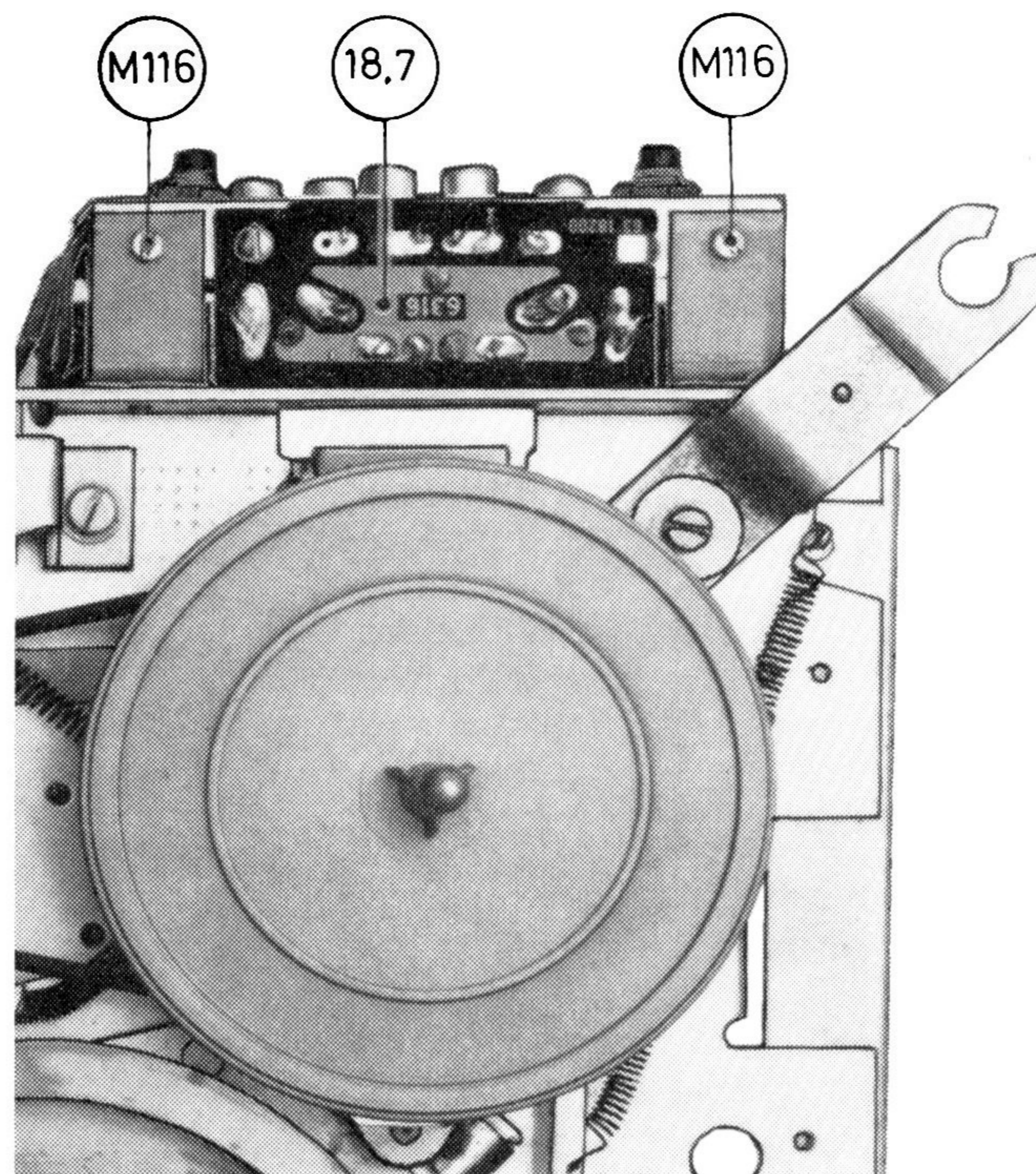

Fig. 52. Top view of the tape recorder with the position of the printed circuit board 18.7.

5.8 THE DISTINCTION BETWEEN THE MODELS 74 – 72 AND 74B – 72B

Mechanical:

The models 74 – 72 and 74B – 72B have exactly the same mechanical drive system.

Electrical:

One playback pre-amplifier output stage for each channel, and one center channel output terminal have been introduced on the models 74B – 72B in addition to a new speaker selector switch. Ref. chapters 5.1.6 and 5.2.2.

The model 72 is the half-track version of the model 74. The model 72B is the half-track version of the model 74B.

Ref. chapter 5.9 for modification from quarter-track to half-track models.

The models 74B – 72B were introduced from serial No. 711001 and modified from ser. No. 715001.

PARTS	MODELS 74 – 72	MODELS 74B – 72B	
		BELOW SER. NO. 715000	ABOVE SER. NO. 715 001
Tube	V4A – ½ ECL 86	V8B – ½ ECC 83	V8B – ½ ECC 83
Tube	V4B – ½ ECL 86	V4 – EL 84	V4 – EL 84
Tube	not introduced	V8A – ½ ECC 83	V8A – ½ ECC 83
R116	100 kohm ½ W ± 10 %	removed	removed
R120	680 kohm ½ W ± 10 %	680 kohm ½ W 10 %	470 kohm ½ W 10 %
R128	not introduced	not introduced	510 kohm ½ W 10 %
R170	680 kohm ½ W ± 10 %	680 kohm ½ W 10 %	470 kohm ½ W 10 %
R178	not introduced	not introduced	510 kohm ½ W 10 %
R166	100 kohm ½ W ± 10 %	removed	removed
R207	150 ohm 1 W ± 10 %	270 ohm 1 W 10 %	270 ohm 1 W 10 %
R213	not introduced	1.2 kohm ½ W 10 %	1.2 kohm ½ W 10 %
R215	not introduced	220 kohm ⅓ W 10 %*	220 kohm ⅓ W 10 %*
R217	not introduced	1 kohm ½ W 10 %	1 kohm ½ W 10 %
R257	150 ohm 1 W ± 10 %	270 ohm 1 W 10 %	270 ohm 1 W 10 %
R263	not introduced	1.2 kohm ½ W 10 %	1.2 kohm ½ W 10 %
R265	not introduced	220 kohm ⅓ W 10 %*	220 kohm ⅓ W 10 %*
R267	not introduced	1 kohm ½ W 10 %	1 kohm ½ W 10 %
R401	not introduced	68 kohm ½ W 10 %	68 kohm ½ W 10 %
R402	not introduced	51 kohm ½ W 10 %	51 kohm ½ W 10 %
R403	not introduced	510 kohm ½ W 10 %	510 kohm ½ W 10 %
R404	not introduced	240 kohm ½ W 10 %	240 kohm ½ W 10 %
R405	not introduced	51 kohm ½ W 10 %	51 kohm ½ W 10 %
R451	not introduced	68 kohm ½ W 10 %	68 kohm ½ W 10 %
R452	not introduced	51 kohm ½ W 10 %	51 kohm ½ W 10 %
R453	not introduced	510 kohm ½ W 10 %	510 kohm ½ W 10 %
R454	not introduced	240 kohm ½ W 10 %	240 kohm ½ W 10 %
R455 balance control	not introduced	100 kohm potentiometer	100 kohm potentiometer
C113	100 μμF 500 V 10 %	100 μμF 500 V 10 %	120 μμF 500 V 10 %
C117	40 000 μμF 150 V 20 %	39 000 μμF 150 V 20 %	39 000 μμF 150 V 20 %
C118	100 μμF 500 V 10 %	100 μμF 500 V 10 %	47 μμF 500 V 10 %
C121	190 μμF 500 V 10 %	190 μμF 500 V 10 %	39 μμF 500 V 10 %
C122	100 μμF 500 V 10 %	100 μμF 500 V 10 %	47 μμF 500 V 10 %
C123	not introduced	not introduced	20 000 μμF 150 V 10 %
C124	not introduced	not introduced	10 000 μμF 150 V 10 %
C125	not introduced	not introduced	30 000 μμF 150 V 10 %
C126	not introduced	not introduced	39 μμF 500 V 10 %
C127	not introduced	not introduced	4/20 μμF trimming cap.
C163	100 μμF 500 V 10 %	100 μμF 500 V 10 %	120 μμF 500 V 10 %
C167	40 000 μμF 150 V 20 %	39 000 μμF 150 V 20 %	39 000 μμF 150 V 20 %
C168	100 μμF 500 V 10 %	100 μμF 500 V 10 %	47 μμF 500 V 10 %
C171	190 μμF 500 V 10 %	190 μμF 500 V 10 %	39 μμF 500 V 10 %
C172	100 μμF 500 V 10 %	100 μμF 500 V 10 %	47 μμF 500 V 10 %
C173	not introduced	not introduced	20 000 μμF 150 V 10 %
C174	not introduced	not introduced	10 000 μμF 150 V 10 %
C175	not introduced	not introduced	30 000 μμF 150 V 10 %
C176	not introduced	not introduced	39 μμF 500 V 10 %
C177	not introduced	not introduced	4/20 μμF trimming cap.
C208	not introduced	47 000 μμF 400 V 20 %	47 000 μμF 400 V 20 %
C209	not introduced	47 000 μμF 400 V 20 %	47 000 μμF 400 V 20 %
C258	not introduced	47 000 μμF 400 V 20 %	47 000 μμF 400 V 20 %
C259	not introduced	47 000 μμF 400 V 20 %	47 000 μμF 400 V 20 %
C401	not introduced	22 000 μμF 400 V 20 %	22 000 μμF 400 V 20 %
C451	not introduced	22 000 μμF 400 V 20 %	22 000 μμF 400 V 20 %
speaker selector switch	type 5703, type 5439	type 6318	type 6318
Equalization switch	type 5016	type 5016	type 5777

* Deposited carbon resistors.

Ref. chapter 5.7.10 for adjustment of the balance control R455.

**5.9 MODIFICATION FROM QUARTER-TRACK
TO HALF-TRACK MODELS**

The following changes have to be introduced when the tape recorders are modified from quarter-track to half-track.

PART	MODELS 74 — 74B	MODELS 72 — 72B
Erase head	15 H	25 H
Record/playback head	24 H	26 H
C112	40 000 $\mu\mu\text{F}$	60 000 $\mu\mu\text{F}$
C120B	8 $\mu\mu\text{F}$	16 $\mu\mu\text{F}$
C162	40 000 $\mu\mu\text{F}$	60 000 $\mu\mu\text{F}$
C170B	8 $\mu\mu\text{F}$	16 $\mu\mu\text{F}$

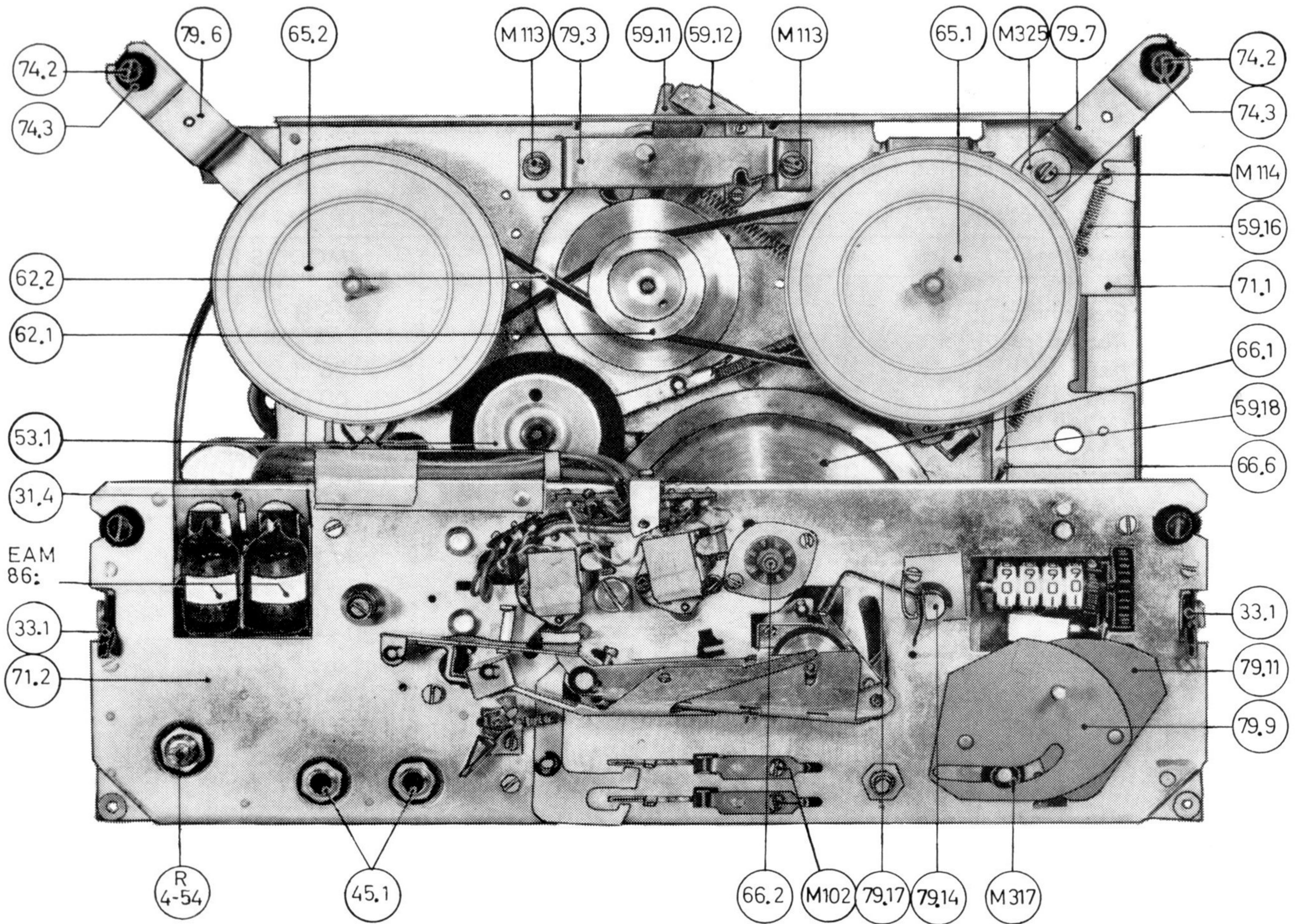

Fig. 53. Top view, with top cover removed. Tape recorders with serial No. below 720 000.

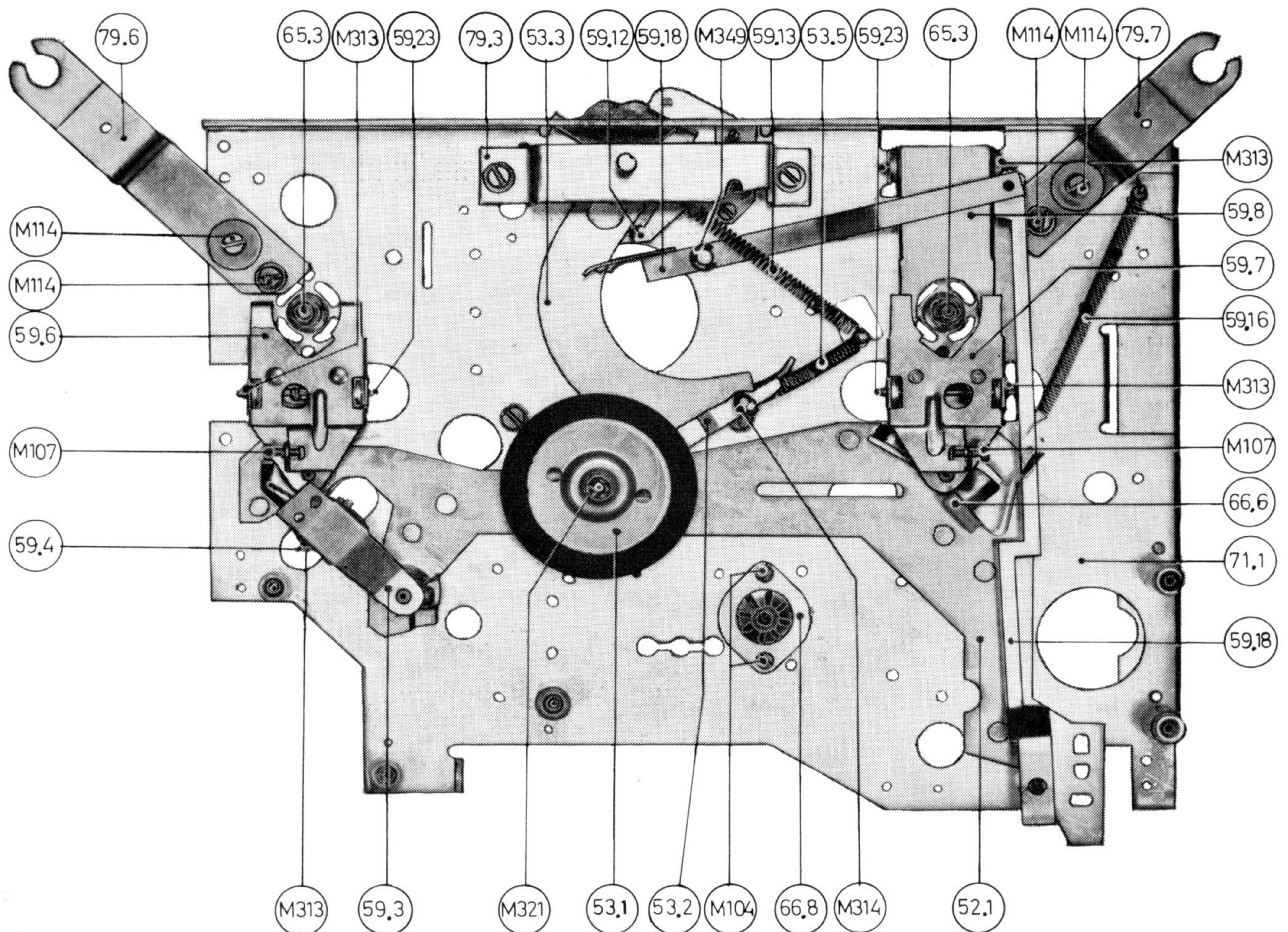

Fig. 54. The lower mounting plate, with the turntables removed. Tape recorders with serial No. below 720 000.

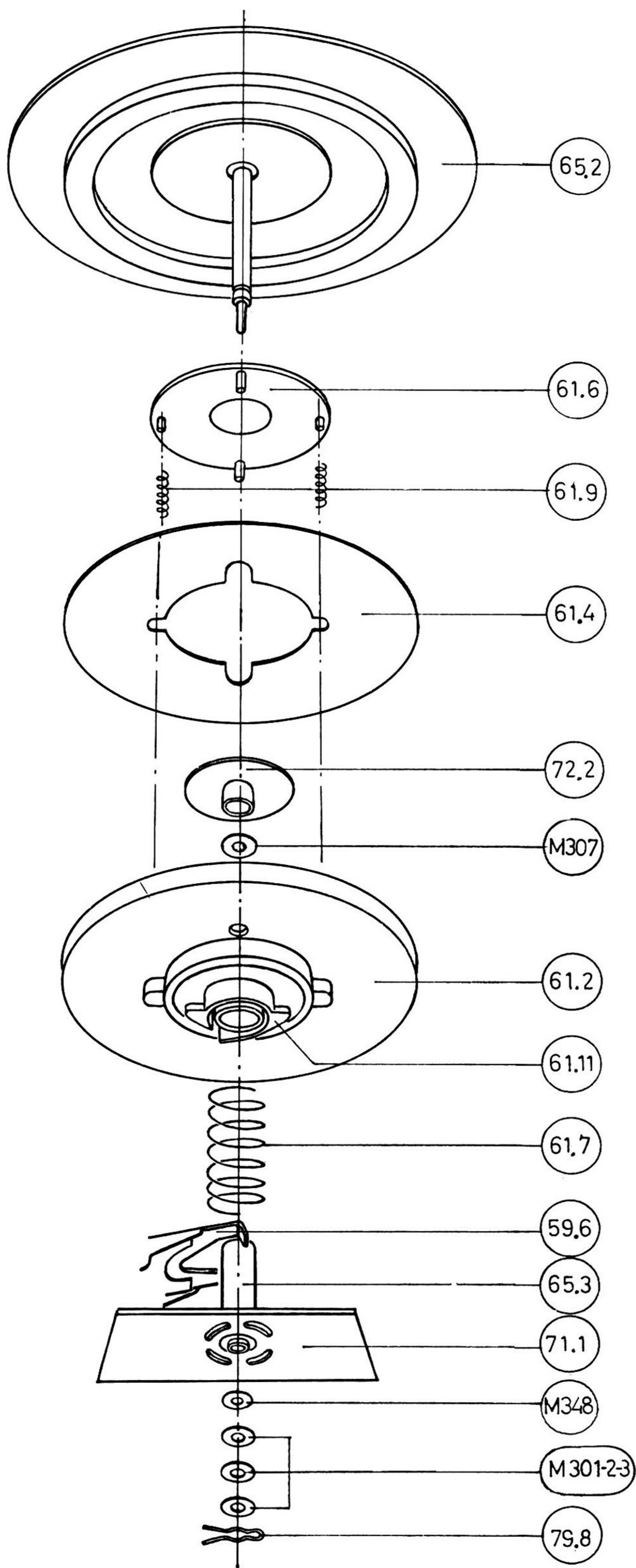

Fig. 55. The supply turntable assembly, exploded view. Tape recorders with serial No. below 719 000.

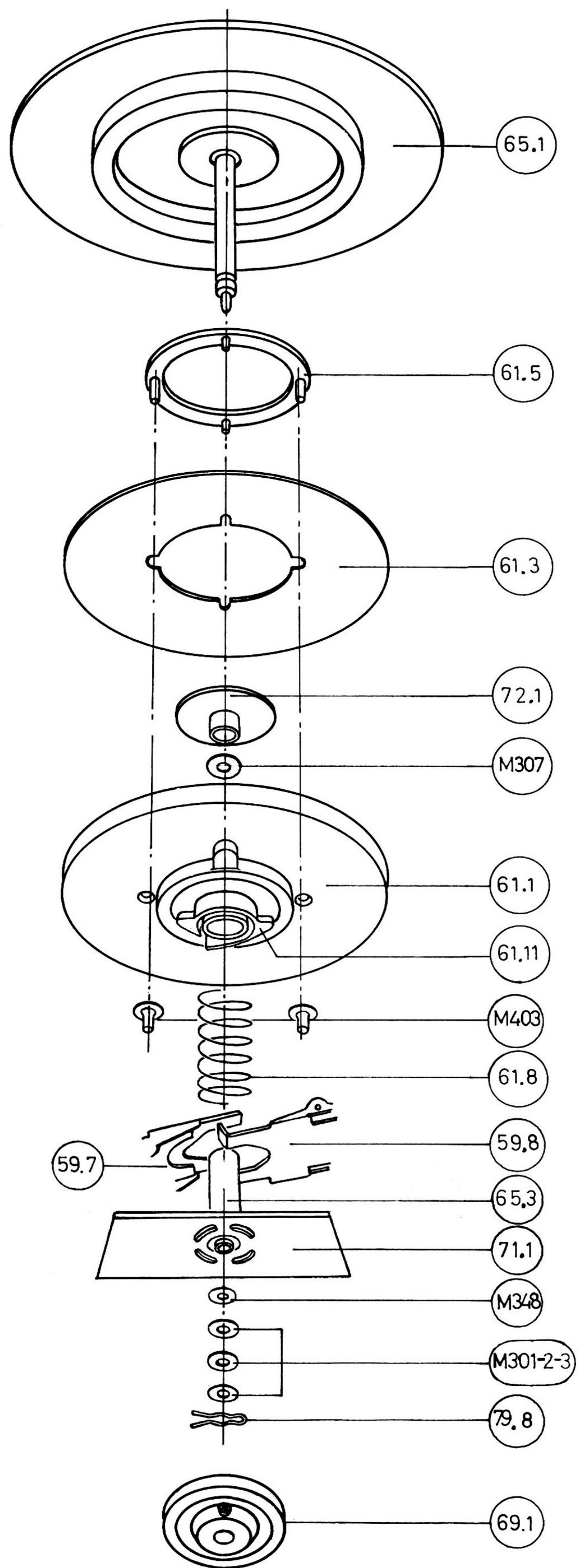

Fig. 56. The take-up turntable assembly, exploded view. Tape recorders with serial No. below 719 000.

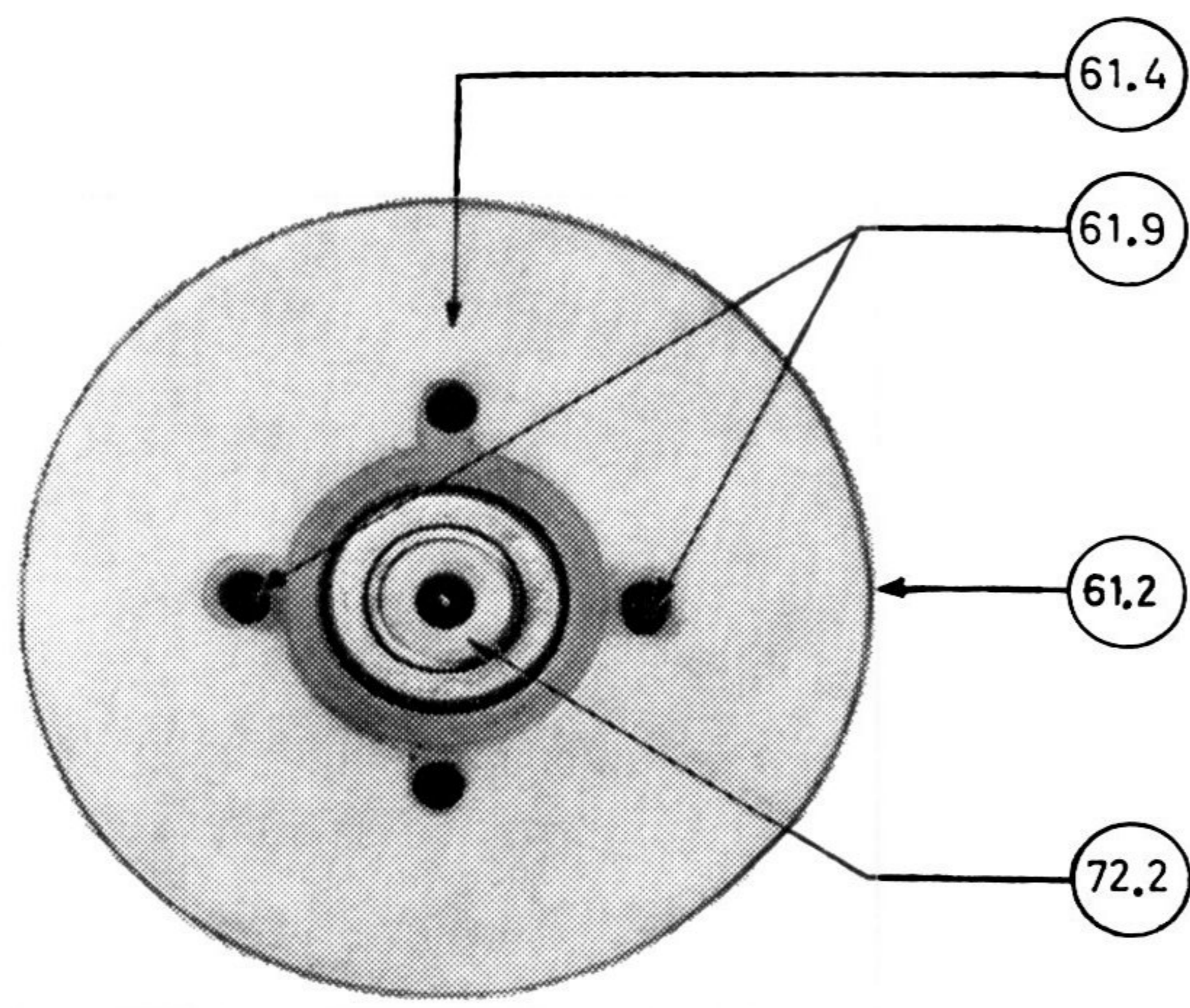

Fig. 57. The supply pulley disc with the mylar sheet.
Tape recorders with serial No. below 719 000.

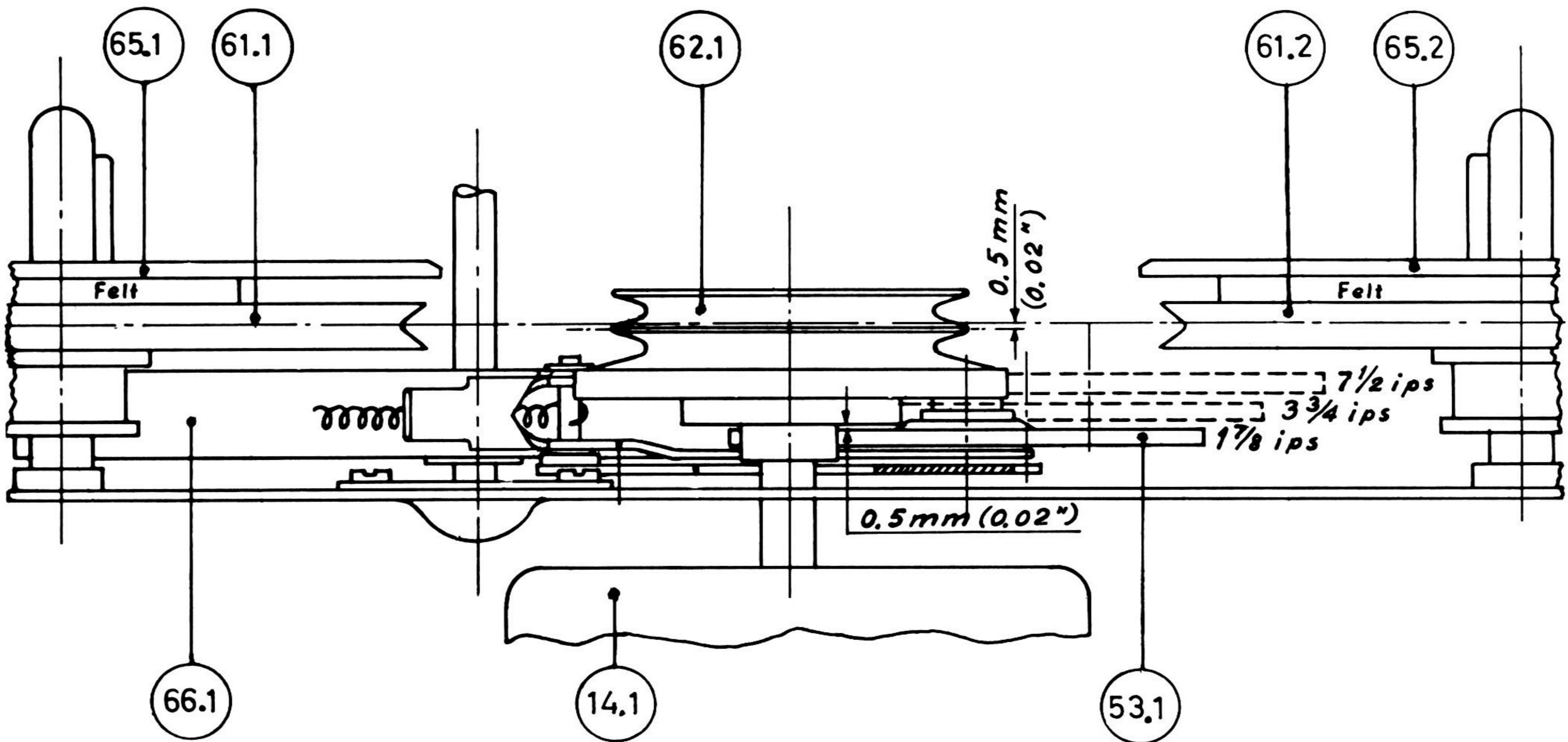

Fig. 58. The alignment of the motor pulley. Tape recorders with serial No. below 720 000.

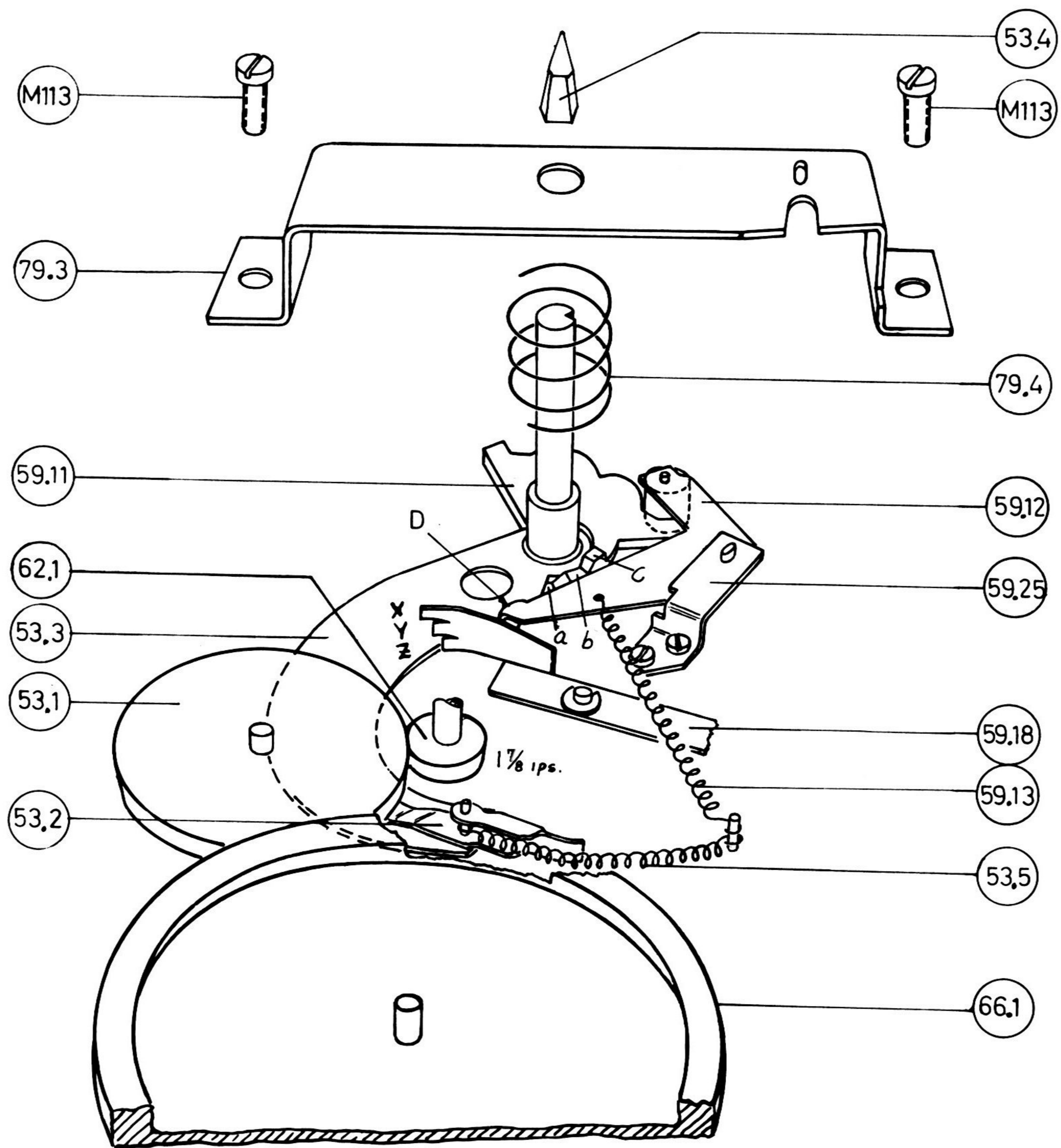

Fig. 59. The speed change mechanism. Tape recorders with serial No. below 720 000.

6.0 Parts list

To improve the equipment, minor changes and modifications have been introduced on the models. The complete reference number of the part and the serial number of the tape recorder must therefore be specified when spare parts are ordered, i.e.

51.9 - 1 - 7C * Tape brake assembly, complete

1 2 3 4

1. The three or four first numbers state the part, and are referred to in all figures.
2. This digit is present only when modification is in-

roduced to the part. In some cases, this number also refers to subcontractors specifications.

3. The type number state the type of tape recorder for which the part is used, i.e.

74 — Parts only for model 74.

72 — Parts only for model 72.

74B — Parts only for model 74B.

72B — Parts only for model 72B.

7C — The part is interchangeable and used for all four models.

4. Modified parts indicated with * may be used as replacement for parts of earlier design.

6.0.1 Mechanical parts

Ref. no.	Description	Fig. ref.	Notes
11.1-280-7C	Power transformer 110—245 V, 50—60 c/s	49	
11.1-281-7C	Power transformer 110 V, 60 c/s	49	
12.1-7C	Output transformer		
14.1-4027-1-7C	Motor, 165 V, 50 c/s	30, 49, 51	
14.1-4027-2-7C	Motor, 165 V, 60 c/s	30, 49, 51	
14.1-4027-3-7C*	Motor, 165 V, 50—60 c/s	30, 49, 51	
14.2-7C	Mounting plate for motor		
14.3-7C	Rubber mounting for motor		
14.4-7C	Spacer for mounting of motor		
18.1-72	Pre-amplifier board with components	50	
18.1-74	Pre-amplifier board with components	50	
18.1-72B	Pre-amplifier board with components	50	
18.1-74B	Pre-amplifier board with components	50	
18.2-72	Playback board with components	49	
18.2-74	Playback board with components	49	
18.2-72B	Playback board with components	49	
18.2-74B	Playback board with components	49	
18.3-7C	Guide stud for printed circuit board	8, 50	
18.4-7C	Tube socket (ECC82, ECC83, ECL86)		
18.5-7C	Tube shield		
18.6-72B	Tube socket (EL84, ECC83)		
18.6-74B	Tube socket (EL84, ECC83)		
18.7-72B	Input board with components	52	
18.7-74B	Input board with components	52	
18.8-72B	Printed circuit board for playback pre-amp, output stage	51	
18.8-74B	Printed circuit board for playback pre-amp, output stage	51	
18.9-72B	Filter board with components	49	Introduced from ser. No. 715001
18.9-74B	Filter board with components	49	Introduced from ser. No. 715001
19.1-7C	Soldering strip for head	10	
19.3-7C	Terminal plate with phono jacks Colour: Yellow and Green		
19.4-7C	Terminal plate with phono jacks Colour: Blue and Red		
19.5-72B	Terminal plate with phono jacks Colour: Red, Black, and Blue		
19.5-74B	Terminal plate with phono jacks Colour: Red, Black, and Blue		
19.6-72	Bracket for terminal plate		
19.6-74	Bracket for terminal plate		
19.6-72B	Bracket for terminal plate		
19.6-74B	Bracket for terminal plate		
24.1-7C	FM-Multiplex filter kit, complete		
31.1-7C	Indicator board with components		
31.2-7C	Bracket for indicator board		

Ref. no.	Description	Fig. ref.	Notes
31.3-7C	Tube socket (EAM86)		
31.4-7C	Spring for indicator tubes	5	
32.2-7C	Double knob, volume control	37	
33.1-7C	Switch (ON-OFF and BASS)	5, 8	
33.2-7C	Microswitch	6, 8	
33.3-7C	Plate spring, microswitch		Removed from ser. No. 706000
33.4-7C	Momentary stop kit, new type	34	Introduced from ser. No. 704001
33.5-7C	Actuator lever		Removed from ser. No. 706000
33.5-1-7C	Actuator lever, delrin	6	Introduced from ser. No. 706001
33.6-7C	Slip-on knob for 33.1		
39.1-7C	Knob, speaker selector switch	37	
39.2-7C	Knob, function selector switch	37	
39.3-7C	Function selector lever, ch. 1	50	
39.4-7C	Function selector lever, ch. 2	50	
39.5-7C	Arm for function selector lever ch. 1 and ch. 2	49	
39.6-7C	Arm for interlock	10	
39.8-7C	Support for 39.5-7C		
39.9-7C	Spring for arm for interlock		Removed from ser. No. 704000
39.9-1-7C	Spring for arm for interlock	10	Introduced from ser. No. 704001
39.11-7C	Muting switch	8	
39.12-7C	Spring for function selector switch	10	
39.13-7C	Screw for arm for interlock		Removed from ser. No. 657000
39.14-7C	Transfer wire for equalization switch, right	49	
39.15-7C	Transfer wire for equalization switch, left	49	
39.16-7C	Support for function selector switch	50	
39.17-1-7C	Speaker selector switch 5703		Removed from ser. No. 640300
39.17-2-7C	Speaker selector switch 5439		Used from ser. No. 640301 to 711000
39.17-3-7C	Speaker selector switch 6318		Introduced from ser. No. 711001
39.22-7C	Return spring, muting switch	8	
44.1-7C	Pilot lamp, 6.3 V, .32 A		
44.2-7C	Socket for pilot lamp		
44.3-7C	Shield for pilot lamp		
45.1-7C	Microphone jack	5	
45.1-1-7	Microphone jack	5	Introduced from ser. No. 706001
45.2-7C	Shield for microphone jack	50	
48.1-7C	Wooden case		
48.2-7C	Buffer, polyethylene		
51.1-7C	Pressure wheel	9, 10	
51.2-7C	Shaft, pressure wheel	9, 10, 34	
51.3-7C	Pressure wheel bracket, complete assembly	9, 10	
51.4-7C	Spring, pressure wheel	9, 34	
51.5-7C	Lever, pressure wheel	10, 34	
51.6-7C	Roller for pressure wheel bracket	8	
51.7-7C	Spring for pressure wheel bracket	8	
51.8-7C	Shaft for lever, pressure wheel	34	
51.9-1-7C*	Tape brake assembly, complete	10, 34	
51.11-7C	Equalization latch	9, 10, 34	
51.13-7C	Brake block for tape brake	10	
52.1-7C	Trip bar	11, 20—29	
53.1-7C	Speed transfer wheel	5, 11, 30, 33	
53.2-1-7C	Transfer wheel holder	59	Removed from ser. No. 720000
53.2-2-7C	Transfer wheel holder	3	Introduced from ser. No. 720001
53.3-7C	Mounting arm, transfer wheel	11, 33	
53.4-7C	Knob, speed selector	37	
53.5-1-7C	Spring, transfer wheel holder	54, 59	Removed from ser. No. 720000
53.5-2-7C	Spring transfer wheel holder	11, 33	Introduced from ser. No. 720001
53.7-7C	Parallel arm	5, 11, 33	Introduced from ser. No. 720001
53.8-7C	Adjustment arm	5, 11, 33	Introduced from ser. No. 720001
54.1-1-7C*	Operating lever, comp. assembly	6, 49	
54.2-7C	Knob, operating lever	37	
54.3-7C	U-spring operating lever		

Ref. no.	Description	Fig. ref.	Notes
54.4-7C	Spacer for microswitch		Removed from ser. No. 706000
54.6-7C	Screw for actuator lever		Removed from ser. No. 706000
54.7-1-7C	Operating lever shaft with delrin ball	6	Introduced from ser. No. 704001
54.8-1-7C	Clips for operating lever	6	Introduced from ser. No. 706001
59.1-7C	Spring with felt for pressure pad	10, 32	
59.2-7C	Pressure pad arm	10, 34	
59.3-7C	Index lever	11, 20, 22, 24, 26, 28	
59.4-7C	Shaft for index lever	11, 20, 22, 24, 26, 28	
59.5-7C	Spring for index lever	20, 22, 24, 26, 28	
59.6-1-7C*	Clutch lever for supply turntable	11, 12, 13, 20, 22, 24, 26, 28	
59.7-1-7C*	Upper clutch lever for take-up turntable	11, 15, 16, 21, 23, 25, 27, 29	
59.8-7C	Lower clutch lever for take-up turntable	11, 15, 16, 21, 23, 25, 27, 29	
59.9-7C	Spring for 59.6-7C and 59.7-7C	20—29	
59.11-7C	Cam disc	5, 33	
59.12-7C	Cam disc arm, complete	5, 11, 33	
59.13-7C	Extension spring, cam disc arm	11, 33	
59.14-7C	Spring for pressure pad arm	34	
59.15-7C	Spring for 59.8-7C	21, 23, 25, 27, 29	
59.16-7C	Spring for linkage arm	5, 11	
59.17-7C	Eccentric segment	8, 34	
59.18-7C	Transfer wheel lifting arm, complete	53, 54, 59	Removed from ser. No. 720000
59.18-1-7C	Transfer wheel lifting arm, complete	5, 11, 33	Introduced from ser. No. 720 001
59.19-7C	Delrin button for clutch lever	13, 16, 20—29	
59.22-7C	Screw for lifting arm		Removed from ser. No. 657000
59.23-7C	Shaft for clutch levers	11, 20—29	
59.24-7C	Transfer bracket	10, 34	
59.25-7C	Bracket for cam disc arm shaft	33	
59.26-7C	Shaft for cam disc arm		
59.28-7C	Shaft eccentric segment (stud)	8	
61.1-7C	Take-up pulley disc (right)	56, 16, 21, 23, 25, 27, 29, 30	Removed from ser. No. 719000
61.1-1-7C	Take-up pulley disc (right)	15, 16, 21, 23, 25, 27, 29, 30	Introduced from ser. No. 719001
61.2-7C	Supply pulley disc (left)	55, 13, 14, 20, 22, 24, 26, 28, 30	Removed from ser. No. 719000
61.2-1-7C	Supply pulley disc (left)	12, 13, 14, 20, 22, 24, 26, 28, 30	Introduced from ser. No. 719001
61.3-7C	Mylar sheet for take-up pulley disc (right)	56	Removed from ser. No. 719000
61.3-1-7C	Mylar sheet for take-up pulley disc	15	Introduced from ser. No. 719001
61.4-7C	Mylar sheet for supply pulley disc (left)	55, 57	Removed from ser. No. 719000
61.4-1-7C	Mylar sheet for supply pulley disc	12, 14	Introduced from ser. No. 719001
61.5-7C	Fixing ring for mylar sheet, take-up pulley (right)	56	Removed from ser. No. 719000
61.6-7C	Tape tight disc	12	
61.7-7C	Helical compression spring, supply pulley (left)	12, 20, 22, 24, 26, 28	
61.8-7C	Helical compression spring, take-up pulley (right)	15, 21, 23, 25, 27, 29	
61.9-7C	Spring for tape tight disc	12, 14	
62.1-5716-7C	Motor Pulley, 50 c/s	5, 30, 33	
62.1-5714-7C	Motor Pulley, 60 c/s	5, 30, 33	
62.2-7C	Rubber drive belt	5	
65.1-7C	Take-up turntable (right)	53, 56, 21, 23, 25, 27, 29, 30	Removed from ser. No. 719000
65.1-1-7C	Take-up turntable (right)	5, 15, 21, 23, 25, 27, 29, 30	Introduced from ser. No. 720 001
65.2-7C	Supply turntable (left)	53, 55, 20, 22, 24, 26, 28, 30	Removed from ser. No. 719000
65.2-1-7C	Supply turntable (left)	5, 12, 20, 22, 24, 26, 28, 30	Introduced from ser. No. 720 001
65.5-7C	Delrin nut	12	Introduced from ser. No. 720 001
66.1-7C	Flywheel, complete	5, 30, 31, 33	
66.3-7C	Bushing for flywheel bearing	8, 31	
66.4-7C	Spring, upper flywheel bearing	31	
66.5-7C	Spring, lower flywheel bearing	31	
66.6-7C	Brake spring with felt pad, flywheel	5, 11	
66.7-7C	Latch for flywheel bearing, threaded	8, 31	
66.8-7C	Latch for flywheel bearing, not threaded	11, 31	
66.71-7C	Felt ring for flywheel bearing	31	
66.81-7C	Thrust washer	31	
69.1-7C	Pulley for revolution counter (turntable)	56	Removed from ser. No. 720000

Ref. no.	Description	Fig. ref.	Notes
69.1-1-7C	Pulley for revolution counter (turntable)	15	Introduced from ser. No. 720001
73.5-7C	Bracket for front trim cover (right)	37	
73.6-7C	Bracket for rear trim cover	10	
74.1-1-74	Top cover, 3 pos. speaker switch, type 5703		
74.1-2-74	Top cover, 3 pos. speaker switch, type 5703, with interlock		
74.1-3-72	Top cover, 3 pos. speaker switch, type 5703		
74.1-4-72	Top cover, 3 pos. speaker switch, type 5703, with interlock		
74.1-5-74	Top cover, 5 pos. speaker switch, type 5439		
74.1-6-74	Top cover, 5 pos. speaker switch, type 5439, with interlock		
74.1-7-72	Top cover, 5 pos. speaker switch, type 5439		
74.1-8-72	Top cover, 5 pos. speaker switch, type 5439, with interlock		
74.1-9-74B	Top cover, 5 pos. speaker switch, type 6318		
74.1-11-74B	Top cover, 5 pos. speaker switch, type 6318, with interlock		
74.1-12-72B	Top cover, 5 pos. speaker switch, type 6318		
74.1-13-72B	Top cover, 5 pos. speaker switch, type 6318, with interlock		
74.2-7C	Mounting screw (4 × 24 mm)	5, 37	
74.3-7C	Rubber mounting	5	
74.4-7C	Washer for mounting screw	37	
74.5-7C	Rubber washer	37	
79.1-7C	Window for revolution counter		
79.2-7C	Window for indicators		
79.3-7C	Speed selector bracket	53, 54, 59	Removed from ser. No. 720000
79.3-1-7C	Speed selector bracket	5, 11, 33	Introduced from ser. No. 720001
79.4-7C	Spring, speed selector	33	
79.6-7C	Mounting bracket, left rear	5, 11	
79.7-7C	Mounting bracket, right rear	5, 11	
79.8-7C	Lock spring, turntables	55, 56	Removed from ser. No. 720000
79.9-7C	Cover plate 1	5	
79.11-7C	Cover plate 2	5	
79.12-7C	Flat spring for cover plate (earlier type)		
79.13-7C	Tape guide, left	10	
79.14-7C	Tape guide, right	5, 10	
79.15-7C	Tape guide, adjustable	10	
79.16-7C	Spring, fuse holder		
79.17-7C	Actuating spring for end stop	5, 10	
79.18-7C	Felt washer for coverplates and knobs	37	Removed from ser. No. 704000
79.19-7C	Push button for momentary stop		Removed from ser. No. 704000
79.21-7C	Spring for momentary stop		Removed from ser. No. 704000
79.22-7C	Bracket for momentary stop		
79.23-7C	Revolution counter	8	
79.24-7C	Bracket for revolution counter	8	
79.25-7C	Bracket for end stop spring		Removed from ser. No. 708000
79.26-7C	Cup for speed selector spring		Removed from ser. No. 708000
79.27-7C	Lever for start/stop push button		
79.28-7C	Stereo emblem		
79.29-7C	Tandberg emblem		Introduced from ser. No. 704001
79.31-7C	Adjustable tape guide (right)	10, 34	Introduced from ser. No. 711001
79.32-7C	Spring for adjustable tape guide (right)		
69.1-1-7C	Pulley for revolution counter (turntable)	15	Introduced from ser. No. 720 001
59.2-7C	Pulley for revolution counter (counter)	15	
69.3-7C	Rubber belt revolution counter	49	
71.3-7C	Leg for lower mounting plate	49, 51	
71.4-7C	Reinforcement bracket, upper mounting plate	8	Removed from ser. No. 711000
71.5-7C	Reinforcement bracket, lower mounting plate	49	Removed from ser. No. 711000
72.1-7C	Flange for take-up turntable housing (right)	15	
72.2-7C	Flange for supply turntable housing (left)	55, 57	Removed from ser. No. 720000

Ref. no.	Description	Fig. ref.	Notes
72.2-1-7C	Flange for supply turntable housing (left)	12, 14	Introduced from ser. No. 720 001 Removed from ser. No. 701000 Introduced from ser. No. 704001
73.1-7C	Front trim cover (earlier momentary start/stop)		
73.1-1-7C	Front trim cover (new momentary start/stop)	37	
73.2-7C	Rear trim cover	37	
73.3-7C	Screw for trim cover	37	
73.4-7C	Bracket for front trim cover (left)	37	

Screws, washers, and lock washers

M101	Screw 3 × 4 mm c.h.
M102	Screw 3 × 4,5 mm c.h.
M104	Screw 3 × 6 mm c.h.
M107	Screw 3 × 8 mm c.h.
M112	Screw 4 × 6 mm c.h.
M113	Screw 4 × 8 mm c.h.
M114	Screw 4 × 10 mm c.h.
M116	Parker screw 1/4" No. 4
M120	Screw 2,6 × 4 mm c.h.
M121	Screw 2,3 × 12 mm c.h.
M122	Screw 4 × 22 mm c.h.
M125	Screw 3 × 6 mm c.h. 1.5 mm head
M130	Screw 3 × 8 mm l.h.
M132	Umbraco screw 1/8" × 3,5 mm

M301	Turbax washer 7,5 × 4,2 × 0,2 mm
M302	Turbax washer 7,5 × 4,2 × 0,3 mm
M303	Turbax washer 7,5 × 4,2 × 0,5 mm
M307	Turbax washer 11 × 6,5 × 0,5 mm
M313	Lock ring 2,5 mm
M314	Lock ring 3 mm
M315	Lock ring 3,5 mm
M317	Lock ring 5 mm
M318	Lock ring 6 mm
M321	Lock ring 4 × 0,6 mm
M325	Washer 16 × 4,2 × 1,65 mm
M329	Lock ring 2,3 mm
M331	Bakelite washer 18 × 10 × 0,5 mm
M333	Spring washer 1/8"
M348	Teflon washer 6,5 × 4,2 × 0,2 mm
M349	Lock washer 4 mm
M355	Teflon washer 6,5 × 4,2 × 0,5 mm
M403	Rivet 3,5 mm

Heads:

15H	Quarter-track, stereo erase head. Models 74 and 74B.
24H	Quarter-track, stereo record/playback head. Models 74 and 74B.
25H	Half-track, stereo erase head. Models 72 and 72B.
26H	Half-track, stereo record/playback head. Models 72 and 72B.

Fuses:

0.2A-7C, 5 × 30 mm slow	} High voltage
0.2A-7C, 5 × 30 mm slow	
6A-7C, 8 × 20 mm slow	Filament voltage

Tubes:

V1-7C, V2-7C	ECC83 (12AX7)
V3-7C	ECC82 (12AU7)

V4-72, V4-74, V5-72, V5-74	ECL86 (6GW8)
V4-72B, V4-74B, V5-72B, V5-74B	EL84 (6BQ5)
V6-7C, V7-7C	EAM86
V8-72B, V8-74B, V9-72B, V9-74B	ECC83 (12AX7)

Coils:

L1/L2-7C	Oscillator coil
L3-7C	FM-MX filter coil ch. 1
L4-7C	FM-MX filter coil ch. 2
L5-72B, L5-74B	Filter coil ch. 1
L6-72B, L6-74B	Filter coil ch. 2

Transistors:

Q1-7C, Q2-7C	AC107
--------------	-------

Diodes:

D1-72B, D1-74B	AA119
D2-72B, D2-74B	AA119

Rectifiers:

B250 C125-7C	High voltage rectifier
--------------	------------------------

6.0.2 Electrical parts

Resistors:

Ref. No.	Description	Notes
R1-72	500 kohm, pot.meter Dralowid 54ZP	R501-72B from ser. No. 711001
R1-74	500 kohm, pot.meter Dralowid 54ZP	R501-74B from ser. No. 711001
R2-72	10 kohm 1/2 w 10 %	R502-72B from ser. No. 711001
R2-74	10 kohm 1/2 w 10 %	R502-74B from ser. No. 711001
R3-72	100 kohm 1/2 w 10 %	R503-72B from ser. No. 711001
R3-74	100 kohm 1/2 w 10 %	R503-74B from ser. No. 711001
R4-7C, R54-7C	250 kohm, double pot.meter 55 U ELAP T5787	
R31-7C	10 kohm 1 w ¹⁾ 10 %	
R32-7C	820 ohm 1 w 10 %	
R33-7C	180 ohm 2 w 10 %	
R34-7C	51 ohm 1/2 w 10 %	
R35-7C	51 ohm 1/2 w 10 %	
R36-7C	51 ohm 1/2 w 10 %	
R37-7C	150 ohm 1 w ¹⁾ 10 %	
R38-7C	150 ohm 1 w ¹⁾ 10 %	
R51-72	500 kohm, pot.meter Dralowid 54ZP	R551-72B from ser. No. 711001
R51-74	500 kohm, pot.meter Dralowid 54ZP	R551-74B from ser. No. 711001
R52-72	10 kohm 1/2 w 10 %	R552-72B from ser. No. 711001
R52-74	10 kohm 1/2 w 10 %	R552-74B from ser. No. 711001
R53-72	100 kohm 1/2 w 10 %	R553-72B from ser. No. 711001
R53-74	100 kohm 1/2 w 10 %	R553-74B from ser. No. 711001
R54-7C, R4-7C	250 kohm, double pot.meter 55 U ELAP T5787	
R101-7C	3,3 Mohm 1/2 w 10 %	
R102-7C	10 kohm 1/2 w 10 %	
R103-7C	200 kohm 1 w ¹⁾ 10 %	
R104-7C	2 kohm 1/2 w 10 %	
R106-7C	100 kohm 1/2 w ¹⁾ 5 %	
R107-7C	18 ohm 1 w 5 %	
R108-7C	20 kohm 1/2 w ¹⁾ 5 %	
R109-7C	10 kohm 1/2 w ¹⁾ 10 %	
R110-7C	20 kohm 1/2 w 10 %	
R111-7C	100 kohm 1/2 w 10 %	
R112-7C	39 kohm 1/2 w 10 %	
R113-7C	1 Mohm 1/2 w 10 %	
R114-7C	47 kohm 1 w 10 %	
R115-7C	2 kohm 1/2 w 10 %	
R116-72	100 kohm 1/2 w 10 %	Removed from ser. No. 711000
R116-74	100 kohm 1/2 w 10 %	Removed from ser. No. 711000
R118-7C	82 ohm 1/2 w 10 %	
R119-1-7C*	33 kohm 1/2 w 10 %	From ser. No. 640300
R120-72	680 kohm 1/2 w 10 %	
R120-74	680 kohm 1/2 w 10 %	
R120-72B	680 kohm 1/2 w 10 %	
R120-74B	680 kohm 1/2 w 10 %	
R120-1-72B	470 kohm 1/2 w 10 %	Introduced from ser. No. 715001
R120-1-74B	470 kohm 1/2 w 10 %	Introduced from ser. No. 715001
R121-7C	1,2 kohm 1/2 w 10 %	
R122-7C	2 kohm 1/2 w 10 %	
R123-7C	3,9 kohm 1/2 w 10 %	
R124-7C	15 kohm 1/2 w 10 %	
R125-7C	1 Mohm 1/2 w 10 %	
R126-7C	250 kohm, pot.meter 82 R	
R127-7C	39 kohm 1/2 w 10 %	
R128-72B	510 kohm 1/2 w 10 %	Introduced from ser. No. 715001
R128-74B	510 kohm 1/2 w 10 %	Introduced from ser. No. 715001
R131-7C	510 ohm 1/2 w 10 %	
R132-7C	15 kohm 1/2 w 10 %	
R133-7C	15 kohm 1/2 w 10 %	

¹⁾ Deposited carbon resistor.

Ref. No.	Description	Notes
R134-7C	1,2 kohm 1/2 w 10 %	
R135-7C	82 kohm 1 w 10 %	
R136-7C	10 kohm 1 w 10 %	
R151-7C	3,3 Mohm 1/2 w 10 %	
R152-7C	10 kohm 1/2 w 10 %	
R153-7C	200 kohm 1 w ¹⁾ 10 %	
R154-7C	2 kohm 1/2 w 10 %	
R156-7C	100 kohm 1/2 w ¹⁾ 5 %	
R157-7C	18 ohm 1 w 5 %	
R158-7C	20 kohm 1/2 w ¹⁾ 5 %	
R159-7C	10 kohm 1/2 w ¹⁾ 10 %	
R160-7C	20 kohm 1/2 w 10 %	
R161-7C	100 kohm 1/2 w 10 %	
R162-7C	39 kohm 1/2 w 10 %	
R163-7C	1 Mohm 1/2 w 10 %	
R164-7C	47 kohm 1 w 10 %	
R165-7C	2 kohm 1/2 w 10 %	
R166-72	100 kohm 1/2 w 10 %	Removed from ser. No. 711000
R166-74	100 kohm 1/2 w 10 %	Removed from ser. No. 411000
R168-74	82 ohm 1/2 w 10 %	
R169-1-7C*	33 kohm 1/2 w 10 %	From ser. No. 640 300
R170-72	680 kohm 1/2 w 10 %	
R170-74	680 kohm 1/2 w 10 %	
R170-72B	680 kohm 1/2 w 10 %	
R170-74B	680 kohm 1/2 w 10 %	
R170-1-72B	470 kohm 1/2 w 10 %	Introduced from ser. No. 715001
R170-1-74B	470 kohm 1/2 w 10 %	Introduced from ser. No. 715001
R171-7C	1,2 kohm 1/2 w 10 %	
R172-7C	2 kohm 1/2 w 10 %	
R173-7C	3,9 kohm 1/2 w 10 %	
R174-7C	15 kohm 1/2 w 10 %	
R175-7C	1 Mohm 1/2 w 10 %	
R176-7C	250 kohm, pot.meter 82 R	
R177-7C	39 kohm 1/2 w 10 %	
R178-72B	510 kohm 1/2 w 10 %	Introduced from ser. No. 715001
R178-74B	510 kohm 1/2 w 10 %	Introduced from ser. No. 715001
R201-7C	270 ohm 1/2 w 10 %	
R202-7C	3,3 kohm 1/2 w 10 %	
R203-7C	200 kohm 1 w 10 %	
R204-7C	10 kohm 1/2 w ¹⁾ 10 %	
R205-7C	680 kohm 1/2 w 10 %	
R206-7C	2 kohm 1/2 w 10 %	
R207-72	150 ohm 1 w ¹⁾ 10 %	
R207-74	150 ohm 1 w ¹⁾ 10 %	
R207-72B	270 ohm 1 w ¹⁾ 10 %	
R207-74B	270 ohm 1 w ¹⁾ 10 %	
R208-7C	4,7 kohm 1/2 w 10 %	
R209-7C	4,7 kohm 1/2 w 10 %	
R210-7C	18 kohm 1/2 w 10 %	
R211-7C	82 ohm 1/2 w 10 %	
R212-7C	680 kohm 1/2 w 10 %	
R213-72B	1,2 kohm 1/2 w 10 %	Introduced from ser. No. 711001
R213-74B	1,2 kohm 1/2 w 10 %	Introduced from ser. No. 711001
R215-72B	220 kohm 1/3 w ¹⁾ 10 %	Introduced from ser. No. 711001
R215-74B	220 kohm 1/3 w ¹⁾ 10 %	Introduced from ser. No. 711001
R217-72B	1 kohm 1/2 w 10 %	Introduced from ser. No. 711001
R217-74B	1 kohm 1/2 w 10 %	Introduced from ser. No. 711001
R251-7C	270 ohm 1/2 w 10 %	
R252-7C	3,3 kohm 1/2 w 10 %	
R253-7C	200 kohm 1 w 10 %	
R254-7C	10 kohm 1/2 w ¹⁾ 10 %	

¹⁾ Deposited carbon resistor.

Ref. No.	Description	Notes
R255-7C	680 kohm 1/2 w 10 %	
R256-7C	2 kohm 1/2 w 10 %	
R257-72	150 ohm 1 w ¹⁾ 10 %	
R257-74	150 ohm 1 w ¹⁾ 10 %	
R257-72B	270 ohm 1 w ¹⁾ 10 %	
R257-74B	270 ohm 1 w ¹⁾ 10 %	
R258-7C	4,7 kohm 1/2 w 10 %	
R259-7C	4,7 kohm 1/2 w 10 %	
R260-7C	18 kohm 1/2 w 10 %	
R261-7C	82 ohm 1/2 w 10 %	
R262-7C	680 kohm 1/2 w 10 %	
R263-72B	1,2 kohm 1/2 w 10 %	Introduced from ser. No. 711001
R263-74B	1,2 kohm 1/2 w 10 %	Introduced from ser. No. 711001
R265-72B	220 kohm 1/3 w ¹⁾ 10 %	Introduced from ser. No. 711001
R265-74B	220 kohm 1/3 w ¹⁾ 10 %	Introduced from ser. No. 711001
R267-72B	1 kohm 1/2 w 10 %	Introduced from ser. No. 711001
R267-74B	1 kohm 1/2 w 10 %	Introduced from ser. No. 711001
R301-7C	150 kohm 1/2 w 10 %	
R302-7C	150 kohm 1/2 w 10 %	
R303-7C	150 kohm 1/2 w 10 %	
R304-7C	10 Mohm 1/2 w 10 %	
R351-7C	150 kohm 1/2 w 10 %	
R352-7C	150 kohm 1/2 w 10 %	
R353-7C	150 kohm 1/2 w 10 %	
R354-7C	10 Mohm 1/2 w 10 %	
R401-72B	68 kohm 1/2 w 10 %	Introduced from ser. No. 711001
R401-74B	68 kohm 1/2 w 10 %	Introduced from ser. No. 711001
R402-72B	51 kohm 1/2 w 10 %	Introduced from ser. No. 711001
R402-74B	51 kohm 1/2 w 10 %	Introduced from ser. No. 711001
R403-72B	510 kohm 1/2 w 10 %	Introduced from ser. No. 711001
R403-74B	510 kohm 1/2 w 10 %	Introduced from ser. No. 711001
R404-72B	240 kohm 1/2 w 10 %	Introduced from ser. No. 711001
R404-74B	240 kohm 1/2 w 10 %	Introduced from ser. No. 711001
R405-72B	51 kohm 1/2 w 10 %	Introduced from ser. No. 711001
R405-74B	51 kohm 1/2 w 10 %	Introduced from ser. No. 711001
R451-72B	68 kohm 1/2 w 10 %	Introduced from ser. No. 711001
R451-74B	68 kohm 1/2 w 10 %	Introduced from ser. No. 711001
R452-72B	51 kohm 1/2 w 10 %	Introduced from ser. No. 711001
R452-74B	51 kohm 1/2 w 10 %	Introduced from ser. No. 711001
R453-72B	510 kohm 1/2 w 10 %	Introduced from ser. No. 711001
R453-74B	510 kohm 1/2 w 10 %	Introduced from ser. No. 711001
R454-72B	240 kohm 1/2 w 10 %	Introduced from ser. No. 711001
R454-74B	240 kohm 1/2 w 10 %	Introduced from ser. No. 711001
R455-72B	51 kohm 1/2 w 10 %	Introduced from ser. No. 711001
R455-74B	100 kohm, pot.meter P 4	Introduced from ser. No. 711001
R501-72B	500 kohm, pot.meter Dralowid 54ZP	R1-72 below ser. No. 711000
R501-74B	500 kohm, pot.meter Dralowid 54ZP	R1-74 below ser. No. 711000
R502-72B	10 kohm 1/2 w 10 %	R2-72 below ser. No. 711000
R502-74B	10 kohm 1/2 w 10 %	R2-74 below ser. No. 711000
R503-72B	100 kohm 1/2 w 10 %	R3-72 below ser. No. 711000
R503-74B	100 kohm 1/2 w 10 %	R3-74 below ser. No. 711000
R551-72B	500 kohm, pot.meter Dralowid 54ZP	R51-72 below ser. No. 711000
R551-74B	500 kohm, pot.meter Dralowid 54ZP	R51-74 below ser. No. 711000
R552-72B	10 kohm 1/2 w 10 %	R52-72 below ser. No. 711000
R552-74B	10 kohm 1/2 w 10 %	R52-74 below ser. No. 711000
R553-72B	100 kohm 1/2 w 10 %	R53-72 below ser. No. 711000
R553-74B	100 kohm 1/2 w 10 %	R53-74 below ser. No. 711000

¹⁾ Deposited carbon resistor.

Capacitors:

Ref. No.	Description	Type	Notes
C1-72	,1 μ F 35 V 20 %	Polyester	C501-72B from ser. No. 711001
C1-74	,1 μ F 35 V 20 %	Polyester	C501-74B from ser. No. 711001
C2-72	33 μ μ F 125 V 10 %	Styroflex	C502-72B from ser. No. 711001
C2-74	33 μ μ F 125 V 10 %	Styroflex	C502-74B from ser. No. 711001
C3-7C	,1 μ F 400 V 20 %	Metalized paper	
C4-7C	2200 μ μ F 1000 V 20 %	Metalized paper	
C5-72	1500 μ μ F 400 V 10 %	Metalized paper	C505-72B from ser. No. 711001
C5-74	1500 μ μ F 400 V 10 %	Metalized paper	C505-74B from ser. No. 711001
C5B-72	800 μ μ F 400 V 10 %	Metalized paper	C505B-72B from ser. No. 711001
C5B-74	800 μ μ F 400 V 10 %	Metalized paper	C505B-74B from ser. No. 711001
C31-7C ¹⁾	50 + 100 + 50 μ F 350 V	Electrolytic	
C32-7C ¹⁾	50 + 100 + 50 μ F 350 V	Electrolytic	
C33-7C ¹⁾	50 + 100 + 50 μ F 350 V	Electrolytic	
C34-7C	,1 μ F 350 V	Oil paper	
C35-7C	1.1 + .1 μ F 380/570 V	Oil paper	
C36-7C ²⁾	50 + 50 + 50 μ F 350 V	Electrolytic	
C37-7C ²⁾	50 + 50 + 50 μ F 350 V	Electrolytic	
C38-7C ²⁾	50 + 50 + 50 μ F 350 V	Electrolytic	
C51-72	,1 μ F 35 V 20 %	Polyester	C551-72B from ser. No. 711001
C51-74	,1 μ F 35 V 20 %	Polyester	C551-74B from ser. No. 711001
C52-72	33 μ μ F 125 V 10 %	Styroflex	C552-72B from ser. No. 711001
C52-74	33 μ μ F 125 V 10 %	Styroflex	C552-74B from ser. No. 711001
C53-7C	,1 μ F 400 V 20 %	Metalized paper	
C54-7C	2200 μ μ F 1000 V 20 %	Metalized paper	
C55-72	1500 μ μ F 400 V 10 %	Metalized paper	C555-72B from ser. No. 711001
C55-74	1500 μ μ F 400 V 10 %	Metalized paper	C555-74B from ser. No. 711001
C55B-72	800 μ μ F 400 V 10 %	Metalized paper	C555B-72B from ser. No. 711001
C55B-74	800 μ μ F 400 V 10 %	Metalized paper	C555B-74B from ser. No. 711001
C101-7C	47000 μ μ F 400 V 20 %	Metalized paper	
C102-7C	25 μ F 12/15 V	Electrolytic	
C103-7C	1000 μ μ F 400 V 10 %	Metalized paper	
C104-7C	4000 μ μ F 400 V 10 %	Metalized paper	
C106-7C	5 μ F 70 V	Electrolytic	
C107-7C	100 μ F 30/35 V	Electrolytic	
C108-7C	25 μ F 12/15 V	Electrolytic	
C109-7C	40000 μ μ F 150 V 20 %	Metalized paper	
C110-7C	25 μ F 12/15 V	Electrolytic	
C111-7C	2 μ F 350 V	Electrolytic	
C112-72	60000 μ μ F 150 V 20 %	Metalized paper	
C112-74	40000 μ μ F 150 V 20 %	Metalized paper	
C112-72B	60000 μ μ F 150 V 20 %	Metalized paper	
C112-74B	40000 μ μ F 150 V 20 %	Metalized paper	
C113-72	100 μ μ F 500 V 10 %	Ceramic	
C113-74	100 μ μ F 500 V 10 %	Ceramic	
C113-72B	100 μ μ F 500 V 10 %	Ceramic	
C113-74B	100 μ μ F 500 V 10 %	Ceramic	
C113-1-72B	120 μ μ F 500 V 10 %	Ceramic	Introduced from ser. No. 715001
C113-1-74B	120 μ μ F 500 V 10 %	Ceramic	Introduced from ser. No. 715001
C114-7C	65 μ μ F 500 V 5 %	Ceramic	
C115-7C	47 μ μ F 500 V 10 %	Ceramic	
C116-7C	3000 μ μ F 400 V 10 %	Metalized paper	
C117-72	40 000 μ μ F 150 V 20 %	Metalized paper	
C117-74	40 000 μ μ F 150 V 20 %	Metalized paper	
C117-72B	39 000 μ μ 150 V 20 %	Metalized paper	
C117-74B	39 000 μ μ 150 V 20 %	Metalized paper	
C118-72	100 μ μ F 500 V 10 %	Ceramic	
C118-74	100 μ μ F 500 V 10 %	Ceramic	
C118-72B	100 μ μ F 500 V 10 %	Ceramic	

¹⁾ C31 - C32 - C33 in the same can.

²⁾ C36 - C37 - C38 in the same can.

Ref. nr.	Description	Type	Notes
C118-74B	100 $\mu\mu\text{F}$ 500 V 10 %	Ceramic	
C118-1-72B	47 $\mu\mu\text{F}$ 500 V 10 %	Ceramic	Introduced from ser. No. 715001
C118-1-74B	47 $\mu\mu\text{F}$ 500 V 10 %	Ceramic	Introduced from ser. No. 715001
C119-7C	47000 $\mu\mu\text{F}$ 400 V 20 %	Metalized paper	
C120-7C	4/20 $\mu\mu\text{F}$ Trimming capacitor	Ceramic	
C120B-72	16 $\mu\mu\text{F}$ 500 V 20 %	Ceramic	
C120B-74	8 $\mu\mu\text{F}$ 500 V 20 %	Ceramic	
C120B-72B	16 $\mu\mu\text{F}$ 500 V 20 %	Ceramic	
C120B-74B	8 $\mu\mu\text{F}$ 500 V 20 %	Ceramic	
C121-72	190 $\mu\mu\text{F}$ 500 V 10 %	Ceramic	
C121-74	190 $\mu\mu\text{F}$ 500 V 10 %	Ceramic	
C121-72B	190 $\mu\mu\text{F}$ 500 V 10 %	Ceramic	
C121-74B	190 $\mu\mu\text{F}$ 500 V 10 %	Ceramic	
C121-1-72B	39 $\mu\mu\text{F}$ 500 V 10 %	Ceramic	Introduced from ser. No. 715001
C121-1-74B	39 $\mu\mu\text{F}$ 500 V 10 %	Ceramic	Introduced from ser. No. 715001
C122-72B	100 $\mu\mu\text{F}$ 500 V 10 %	Ceramic	
C122-74B	100 $\mu\mu\text{F}$ 500 V 10 %	Ceramic	
C122-1-72B	47 $\mu\mu\text{F}$ 500 V 10 %	Ceramic	Introduced from ser. No. 715001
C122-1-74B	47 $\mu\mu\text{F}$ 500 V 10 %	Ceramic	Introduced from ser. No. 715001
C123-72B	20 000 $\mu\mu\text{F}$ 150 V 10 %	Metalized paper	Introduced from ser. No. 715001
C123-74B	20 000 $\mu\mu\text{F}$ 150 V 10 %	Metalized paper	Introduced from ser. No. 715001
C124-72B	10 000 $\mu\mu\text{F}$ 150 V 10 %	Metalized paper	Introduced from ser. No. 715001
C124-74B	10 000 $\mu\mu\text{F}$ 150 V 10 %	Metalized paper	Introduced from ser. No. 715001
C125-72B	30 000 $\mu\mu\text{F}$ 150 V 10 %	Metalized paper	Introduced from ser. No. 715001
C125-74B	30 000 $\mu\mu\text{F}$ 150 V 10 %	Metalized paper	Introduced from ser. No. 715001
C126-72B	39 $\mu\mu\text{F}$ 500 V 10 %	Ceramic	Introduced from ser. No. 715001
C126-74B	39 $\mu\mu\text{F}$ 500 V 10 %	Ceramic	Introduced from ser. No. 715001
C127-72B	4/20 $\mu\mu\text{F}$ Trimming capacitor	Ceramic	Introduced from ser. No. 715001
C127-74B	4/20 $\mu\mu\text{F}$ Trimming capacitor	Ceramic	Introduced from ser. No. 715001
C131-7C	3000 $\mu\mu\text{F}$ 500 V 2 1/2 %	Styroflex	
C132-7C	2000 $\mu\mu\text{F}$ 500 V 2 1/2 %	Styroflex	
C133-7C	2000 $\mu\mu\text{F}$ 500 V 2 1/2 %	Styroflex	
C134-7C	47000 $\mu\mu\text{F}$ 400 V 20 %	Metalized paper	
C135-7C	16 μF 350 V	Electrolytic	
C136-7C		Electrolytic	
C151-7C	47000 $\mu\mu\text{F}$ 400 V 20 %	Metalized paper	
C152-7C	25 μF 12/15 V	Electrolytic	
C153-7C	1000 $\mu\mu\text{F}$ 400 V 10 %	Metalized paper	
C154-7C	4000 $\mu\mu\text{F}$ 400 V 10 %	Metalized paper	
C156-7C	5 μF 70 V	Electrolytic	
C157-7C	100 μF 30/35 V	Electrolytic	
C158-7C	25 μF 12/15 V	Electrolytic	
C159-7C	40000 $\mu\mu\text{F}$ 150 V 20 %	Metalized paper	
C160-7C	25 μF 12/15 V	Electrolytic	
C161-7C	2 μF 350 V	Electrolytic	
C162-72	60000 $\mu\mu\text{F}$ 150 V 20 %	Metalized paper	
C162-74	40000 $\mu\mu\text{F}$ 150 V 20 %	Metalized paper	
C162-72B	60000 $\mu\mu\text{F}$ 150 V 20 %	Metalized paper	
C162-74B	40000 $\mu\mu\text{F}$ 150 V 20 %	Metalized paper	
C163-72	100 $\mu\mu\text{F}$ 500 V 10 %	Ceramic	
C163-74	100 $\mu\mu\text{F}$ 500 V 10 %	Ceramic	
C163-72B	100 $\mu\mu\text{F}$ 500 V 10 %	Ceramic	
C163-74B	100 $\mu\mu\text{F}$ 500 V 10 %	Ceramic	
C163-1-72B	120 $\mu\mu\text{F}$ 500 V 10 %	Ceramic	Introduced from ser. No. 715001
C163-1-74B	120 $\mu\mu\text{F}$ 500 V 10 %	Ceramic	Introduced from ser. No. 715001
C164-7C	65 $\mu\mu\text{F}$ 500 V 5 %	Ceramic	
C165-7C	47 $\mu\mu\text{F}$ 500 V 10 %	Ceramic	
C166-7C	3000 $\mu\mu\text{F}$ 400 V 10 %	Metalized paper	
C167-72	40 000 $\mu\mu\text{F}$ 150 V 20 %	Metalized paper	
C167-74	40 000 $\mu\mu\text{F}$ 150 V 20 %	Metalized paper	
C167-72B	39 000 $\mu\mu\text{F}$ 150 V 20 %	Metalized paper	
C167-74B	39 000 $\mu\mu\text{F}$ 150 V 20 %	Metalized paper	

Ref. No.	Description	Type	Notes
C168-72	100 $\mu\mu\text{F}$ 500 V 10 %	Ceramic	
C168-74	100 $\mu\mu\text{F}$ 500 V 10 %	Ceramic	
C168-72B	100 $\mu\mu\text{F}$ 500 V 10 %	Ceramic	
C168-74B	100 $\mu\mu\text{F}$ 500 V 10 %	Ceramic	
C168-1-72B	47 $\mu\mu\text{F}$ 500 V 10 %	Ceramic	Introduced from ser. No. 715001
C168-1-74B	47 $\mu\mu\text{F}$ 500 V 10 %	Ceramic	Introduced from ser. No. 715001
C169-7C	47000 $\mu\mu\text{F}$ 400 V 20 %	Metalized paper	
C170-7C	4/20 $\mu\mu\text{F}$ Trimming capacitor	Ceramic	
C170B-72	16 $\mu\mu\text{F}$ 500 V 20 %	Ceramic	
C170B-74	8 $\mu\mu\text{F}$ 500 V 20 %	Ceramic	
C170B-72B	16 $\mu\mu\text{F}$ 500 V 20 %	Ceramic	
C170B-74B	8 $\mu\mu\text{F}$ 500 V 20 %	Ceramic	
C171-72	190 $\mu\mu\text{F}$ 500 V 10 %	Ceramic	
C171-74	190 $\mu\mu\text{F}$ 500 V 10 %	Ceramic	
C171-72B	190 $\mu\mu\text{F}$ 500 V 10 %	Ceramic	
C171-74B	190 $\mu\mu\text{F}$ 500 V 10 %	Ceramic	
C171-1-72B	39 $\mu\mu\text{F}$ 500 V 10 %	Ceramic	Introduced from ser. No. 715001
C171-1-74B	39 $\mu\mu\text{F}$ 500 V 10 %	Ceramic	Introduced from ser. No. 715001
C172-72B	100 $\mu\mu\text{F}$ 500 V 10 %	Ceramic	
C172-74B	100 $\mu\mu\text{F}$ 500 V 10 %	Ceramic	
C172-1-72B	47 $\mu\mu\text{F}$ 500 V 10 %	Ceramic	Introduced from ser. No. 715001
C172-1-74B	47 $\mu\mu\text{F}$ 500 V 10 %	Ceramic	Introduced from ser. No. 715001
C173-72B	20000 $\mu\mu\text{F}$ 150 V 10 %	Metalized paper	Introduced from ser. No. 715001
C173-74B	20000 $\mu\mu\text{F}$ 150 V 10 %	Metalized paper	Introduced from ser. No. 715001
C174-72B	10000 $\mu\mu\text{F}$ 150 V 10 %	Metalized paper	Introduced from ser. No. 715001
C174-74B	10000 $\mu\mu\text{F}$ 150 V 10 %	Metalized paper	Introduced from ser. No. 715001
C175-72B	30000 $\mu\mu\text{F}$ 150 V 10 %	Metalized paper	Introduced from ser. No. 715001
C175-74B	30000 $\mu\mu\text{F}$ 150 V 10 %	Metalized paper	Introduced from ser. No. 715001
C176-72B	39 $\mu\mu\text{F}$ 500 V 10 %	Metalized paper	Introduced from ser. No. 715001
C176-74B	39 $\mu\mu\text{F}$ 500 V 10 %	Metalized paper	Introduced from ser. No. 715001
C177-72B	4/20 $\mu\mu\text{F}$ Trimming capacitor	Ceramic	Introduced from ser. No. 715001
C177-74B	4/20 $\mu\mu\text{F}$ Trimming capacitor	Ceramic	Introduced from ser. No. 715001
C201-7C	16 μF 350 V	Electrolytic	
C202-7C	25 μF 12/15 V	Electrolytic	
C203-7C	47000 $\mu\mu\text{F}$ 400 V 20 %	Metalized paper	
C204-7C	100 μF 15/18 V	Electrolytic	
C205-7C	500 $\mu\mu\text{F}$ 600 V 10 %	Metalized paper	
C206-7C	47000 $\mu\mu\text{F}$ 400 V 20 %	Metalized paper	
C207-7C	,6 μF 200 V 20 %	Metalized paper	
C208-72B	47000 $\mu\mu\text{F}$ 400 V 20 %	Metalized paper	
C208-74B	47000 $\mu\mu\text{F}$ 400 V 20 %	Metalized paper	
C209-72B	47 000 $\mu\mu\text{F}$ 400 V 20 %	Metalized paper	
C209-74B	47 000 $\mu\mu\text{F}$ 400 V 20 %	Metalized paper	
C251-7C	16 μF 350 V	Electrolytic	
C252-7C	25 μF 12/15 V	Electrolytic	
C253-7C	47000 $\mu\mu\text{F}$ 400 V 20 %	Metalized paper	
C254-7C	100 μF 15/18 V	Electrolytic	
C255-7C	500 $\mu\mu\text{F}$ 600 V 10 %	Metalized paper	
C256-7C	47000 $\mu\mu\text{F}$ 400 V 20 %	Metalized paper	
C257-7C	,6 μF 200 V 20 %	Metalized paper	
C258-72B	47000 $\mu\mu\text{F}$ 400 V 20 %	Metalized paper	
C258-74B	47000 $\mu\mu\text{F}$ 400 V 20 %	Metalized paper	
C259-72B	47 000 $\mu\mu\text{F}$ 400 V 20 %	Metalized paper	
C259-74B	47 000 $\mu\mu\text{F}$ 400 V 20 %	Metalized paper	
C301-7C	10000 $\mu\mu\text{F}$ 400 V 20 %	Metalized paper	
C302-7C	22000 $\mu\mu\text{F}$ 400 V 20 %	Metalized paper	
C351-7C	10000 $\mu\mu\text{F}$ 400 V 20 %	Metalized paper	
C352-7C	22000 $\mu\mu\text{F}$ 400 V 20 %	Metalized paper	
C401-72B	22000 $\mu\mu\text{F}$ 400 V 20 %	Metalized paper	
C401-74B	22000 $\mu\mu\text{F}$ 400 V 20 %	Metalized paper	
C451-72B	22000 $\mu\mu\text{F}$ 400 V 20 %	Metalized paper	
C451-74B	22000 $\mu\mu\text{F}$ 400 V 20 %	Metalized paper	

Ref. No.	Description	Type	Notes
C501-72B	,1 μ F 35 V 20 %	Polyester	C1-72 below ser. No. 711000
C501-74B	,1 μ F 35 V 20 %	Polyester	C1-74 below ser. No. 711000
C502-72B	33 μ μ F 125 V 10 %	Styroflex	C2-72 below ser. No. 711000
C502-74B	33 μ μ F 125 V 10 %	Styroflex	C2-74 below ser. No. 711000
C505-72B	1500 μ μ F 400 V 10 %	Metalized paper	C5-72 below ser. No. 711000
C505-74B	1500 μ μ F 400 V 10 %	Metalized paper	C5-74 below ser. No. 711000
C505B-72B	800 μ μ F 400 V 10 %	Metalized paper	C5B-72 below ser. No. 711000
C505B-74B	800 μ μ F 400 V 10 %	Metalized paper	C5B-74 below ser. No. 711000
C551-72B	,1 μ F 35 V 20 %	Polyester	C51-72 below ser. No. 711000
C551-74B	,1 μ F 35 V 20 %	Polyester	C51-74 below ser. No. 711000
C552-72B	33 μ F 125 V 10 %	Styroflex	C52-72 below ser. No. 711000
C552-74B	33 μ F 125 V 10 %	Styroflex	C52-74 below ser. No. 711000
C555-72B	1500 μ μ F 400 V 10 %	Metalized paper	C55-72 below ser. No. 711000
C555-74B	1500 μ μ F 400 V 10 %	Metalized paper	C55-74 below ser. No. 711000
C555B-72B	800 μ μ F 400 V 10 %	Metalized paper	C55B-72 below ser. No. 711000
C555B-74B	800 μ μ F 400 V 10 %	Metalized paper	C55B-74 below ser. No. 711000

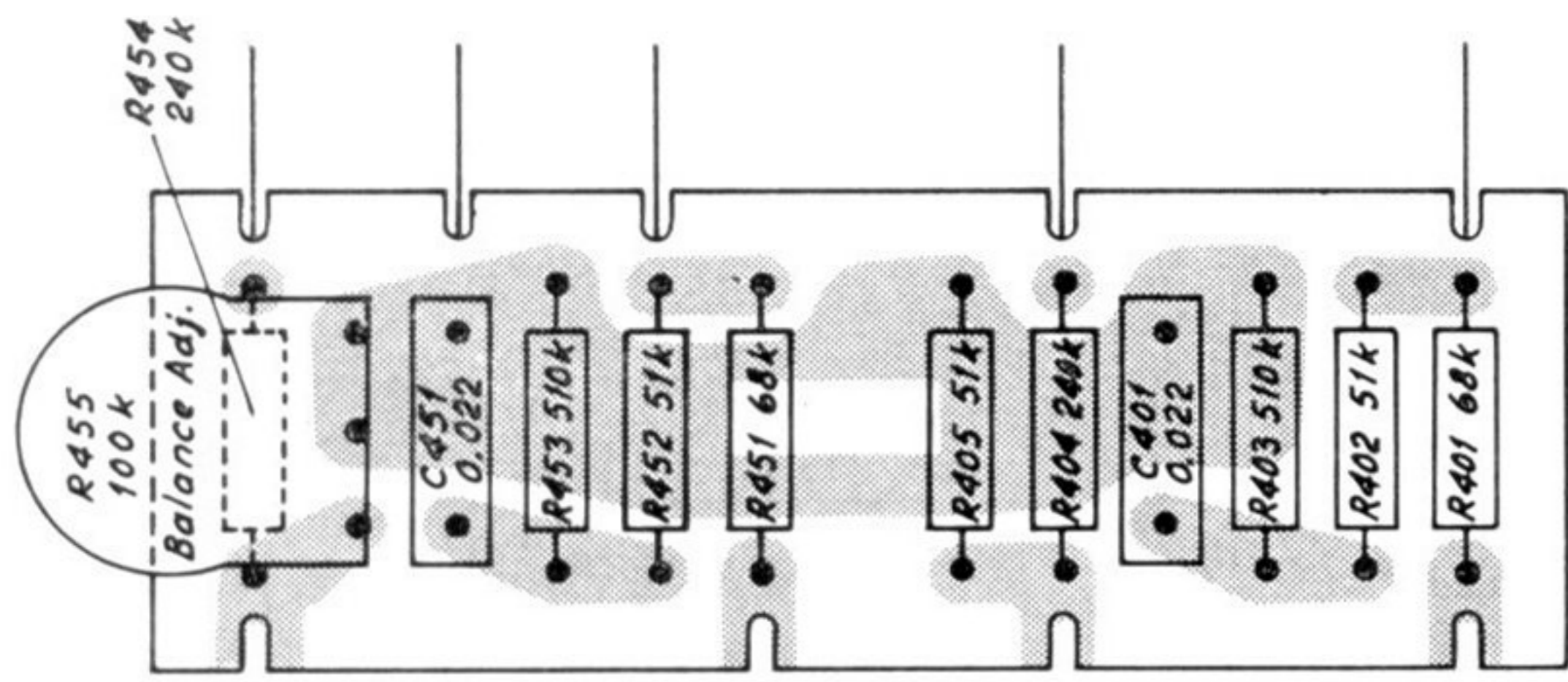

Fig. 60. The output board 6315, component side.

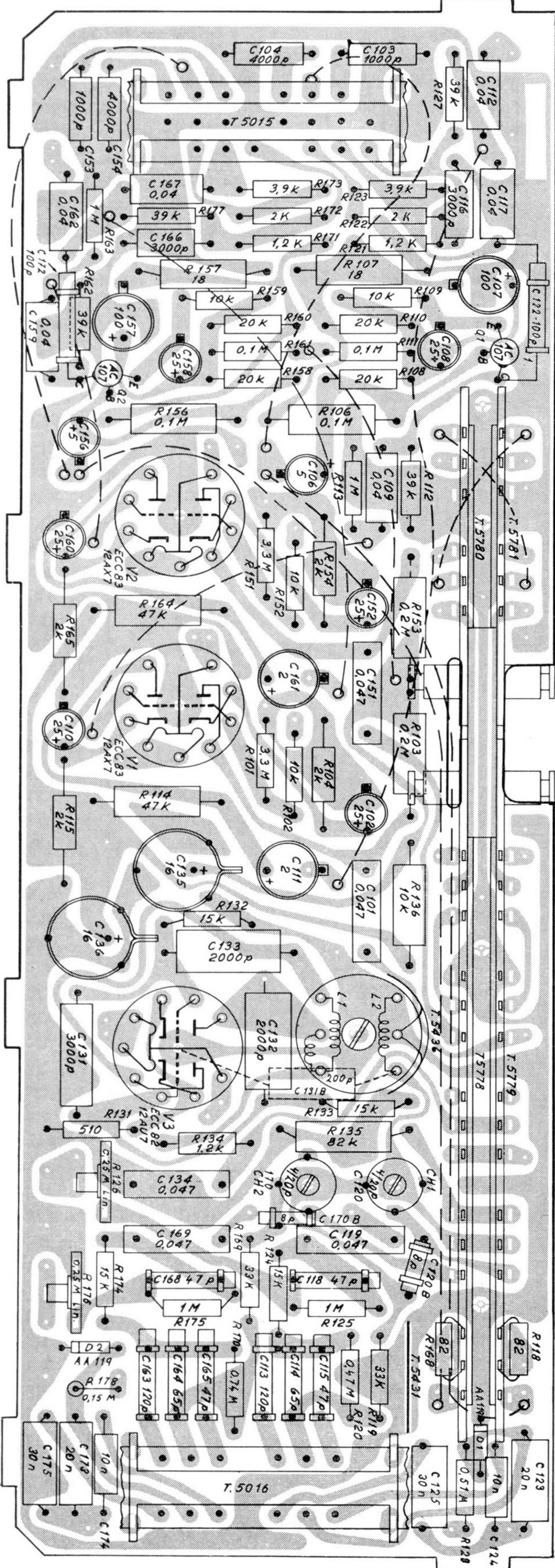

Fig. 61. The amplifier board 6354, component side.

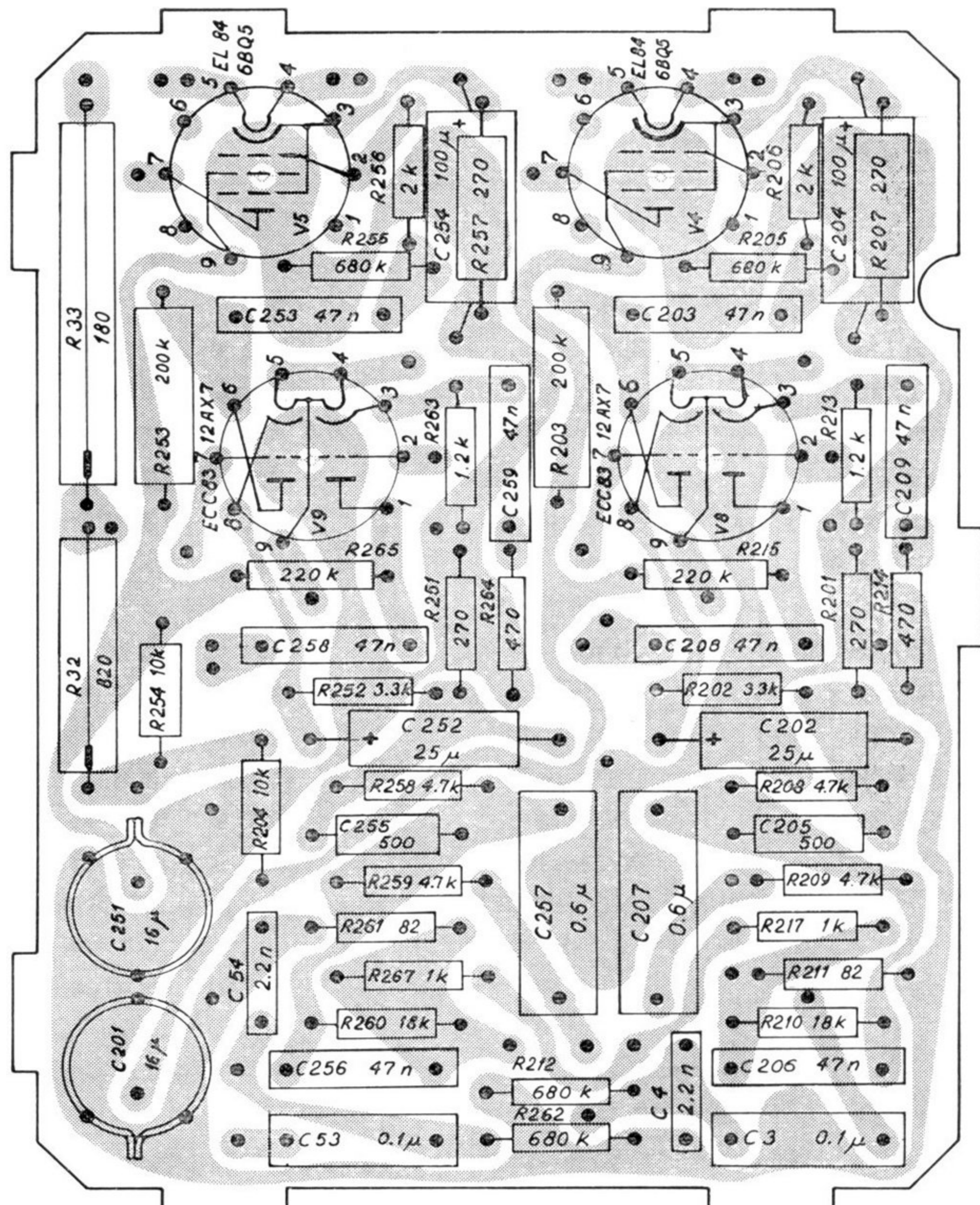

Fig. 62. The output amplifier board 5444, component side.

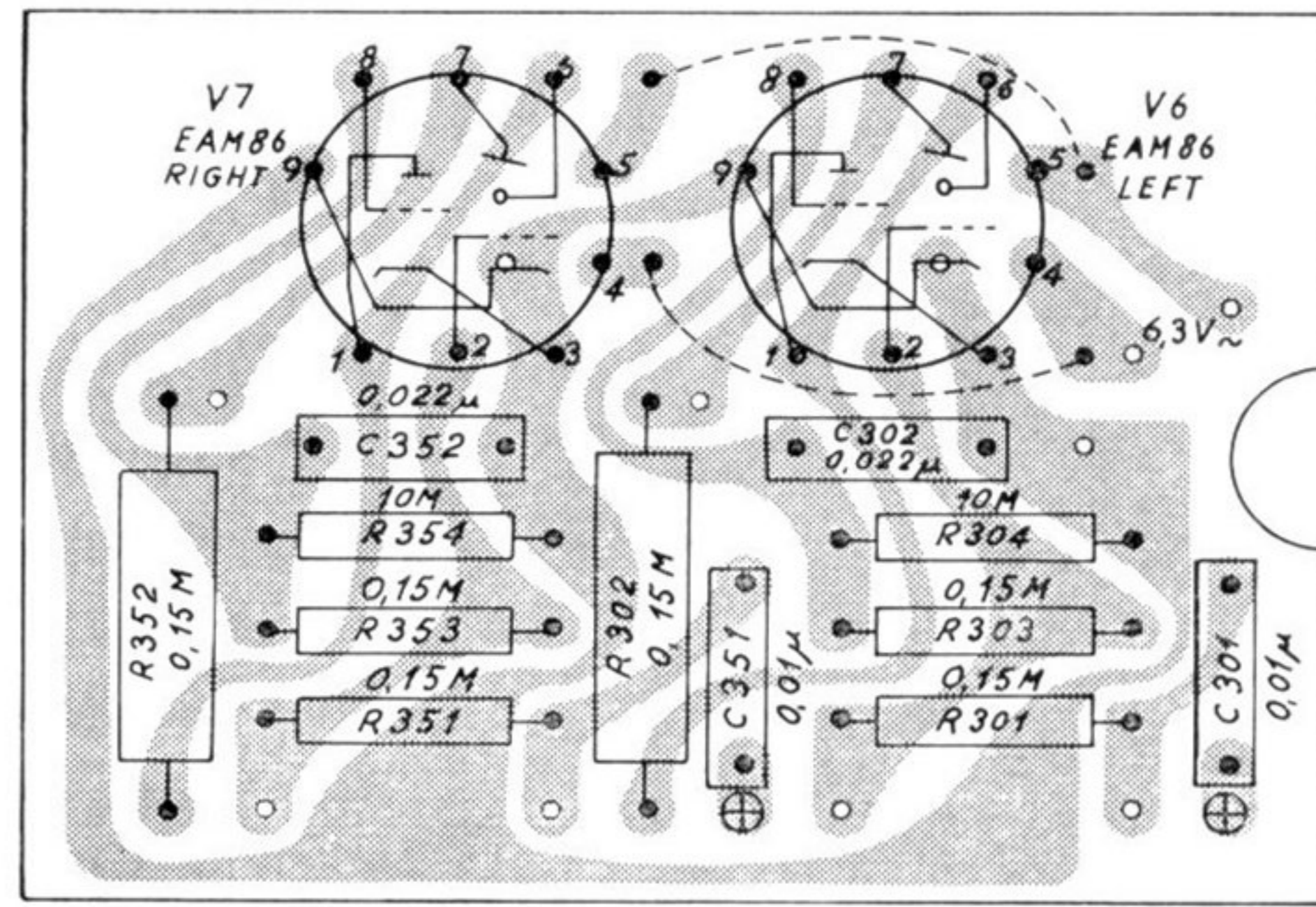

Fig. 63. The indicator board 5454, component side.

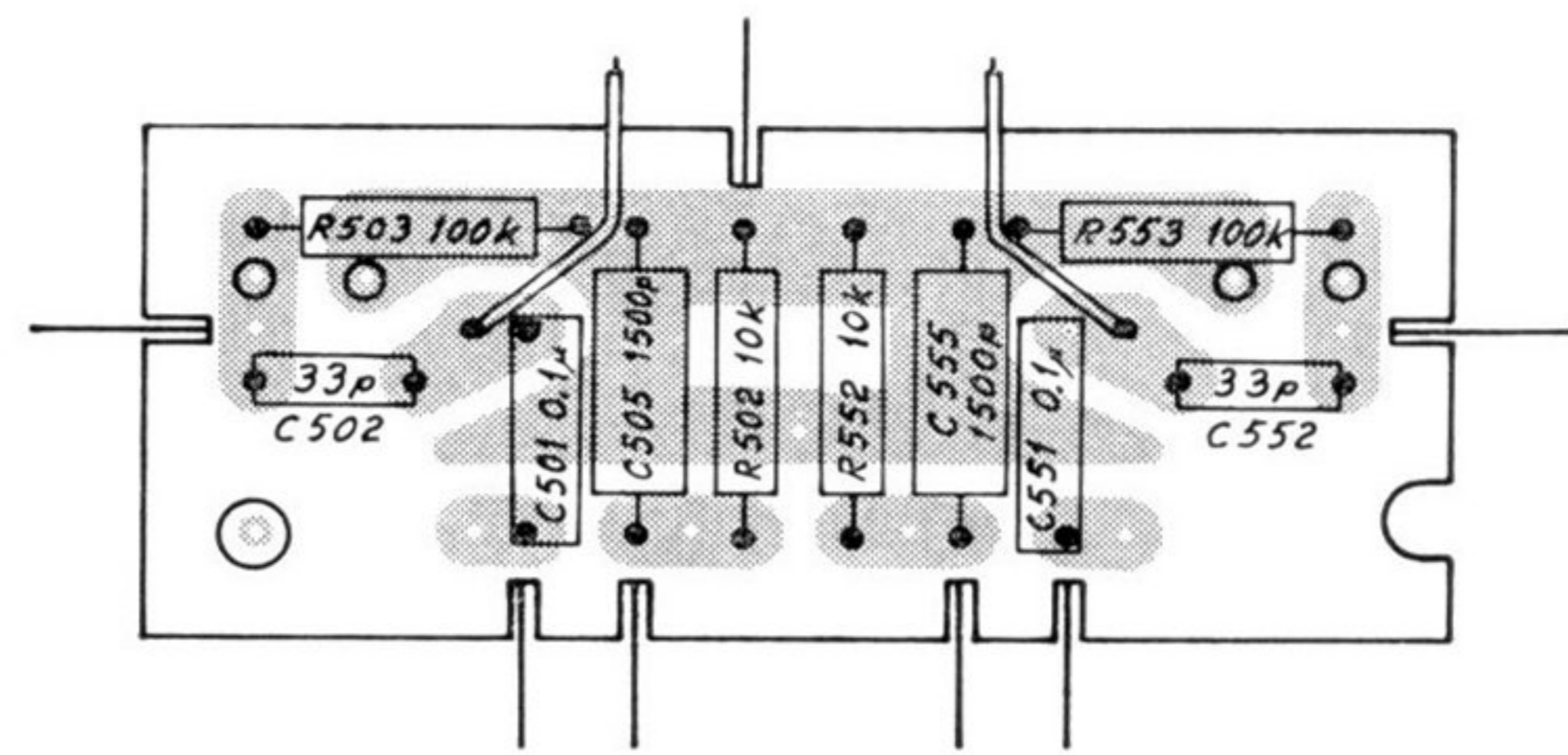

Fig. 64. The input board 6316, component side.

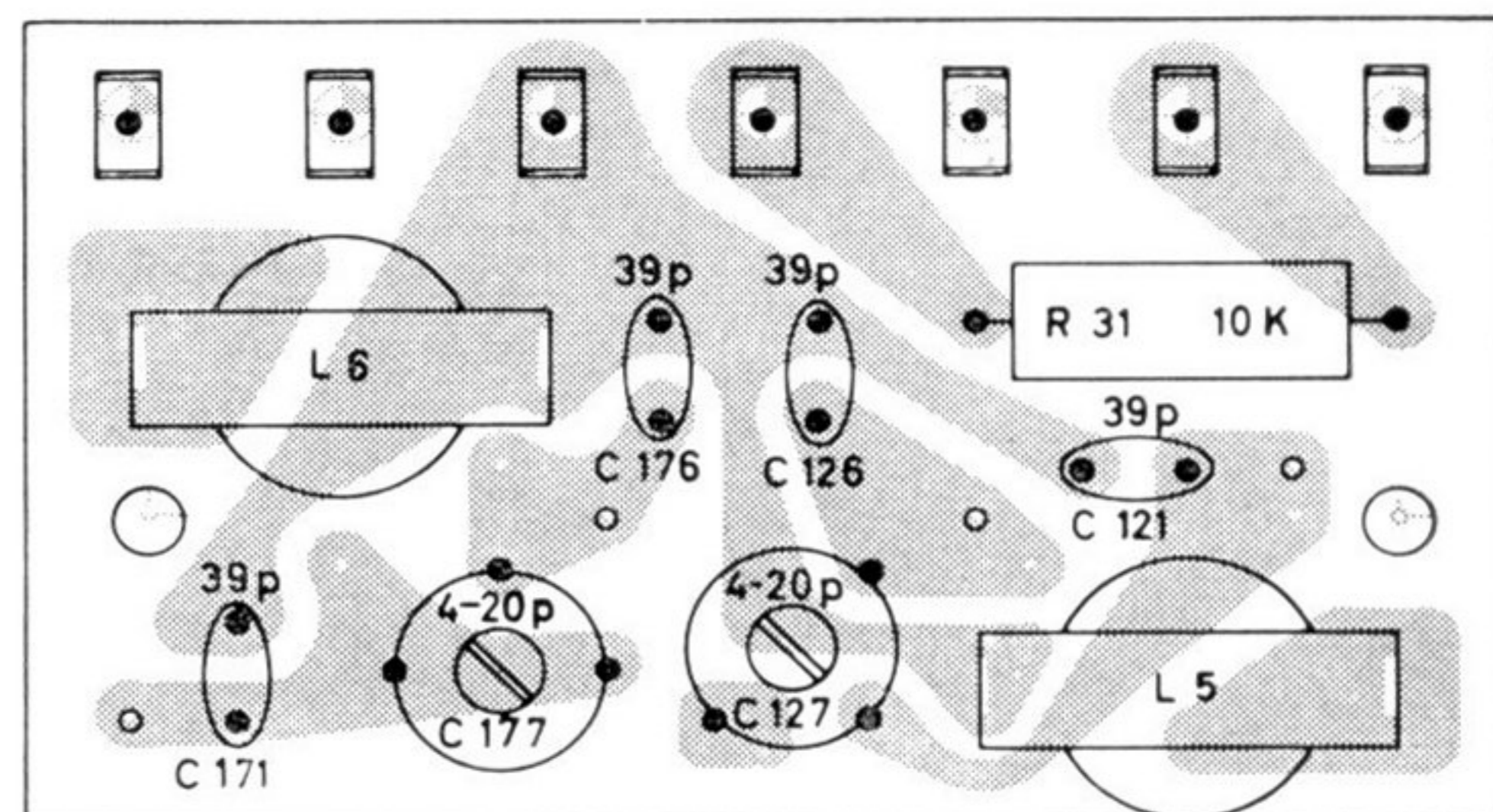
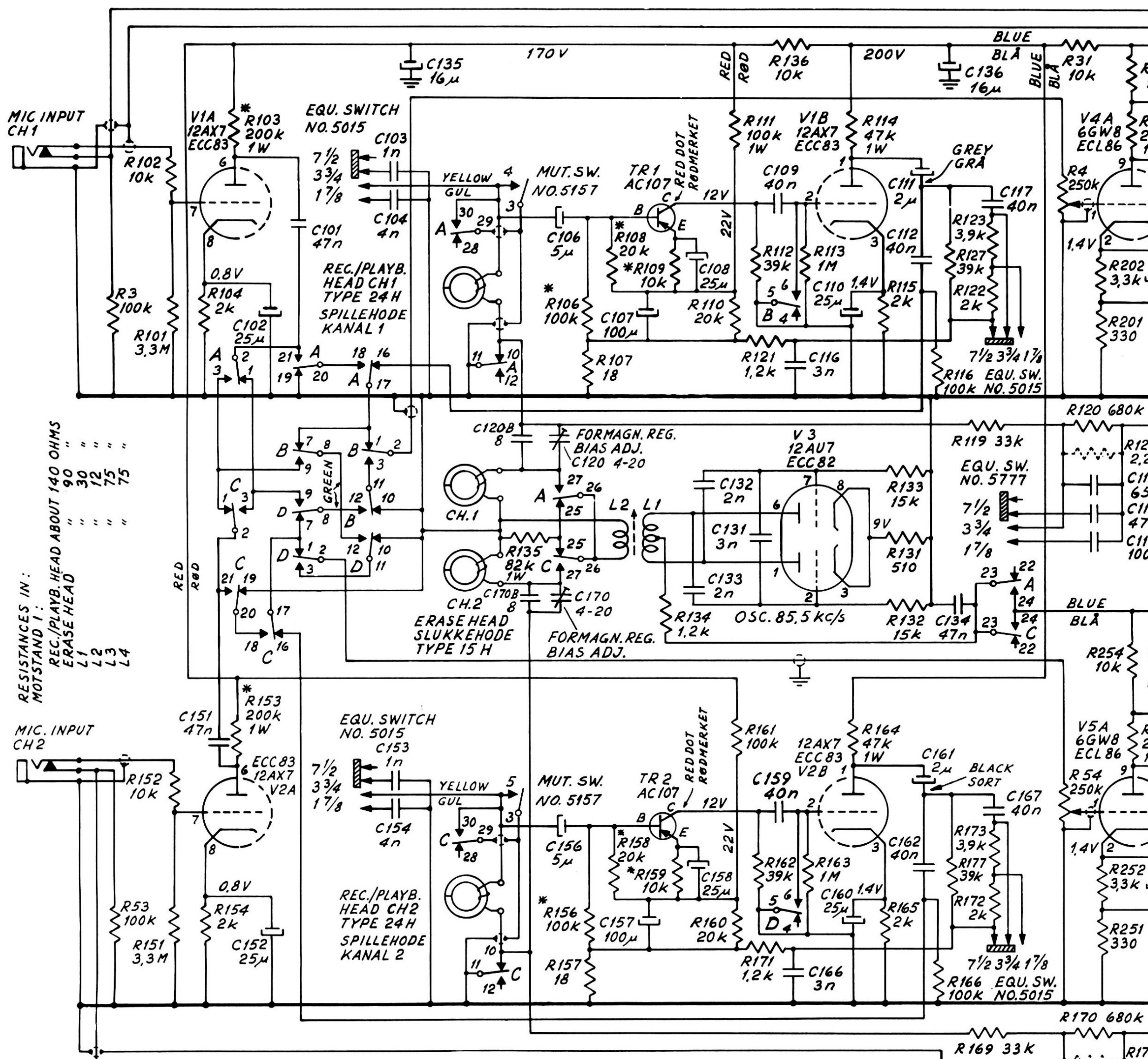
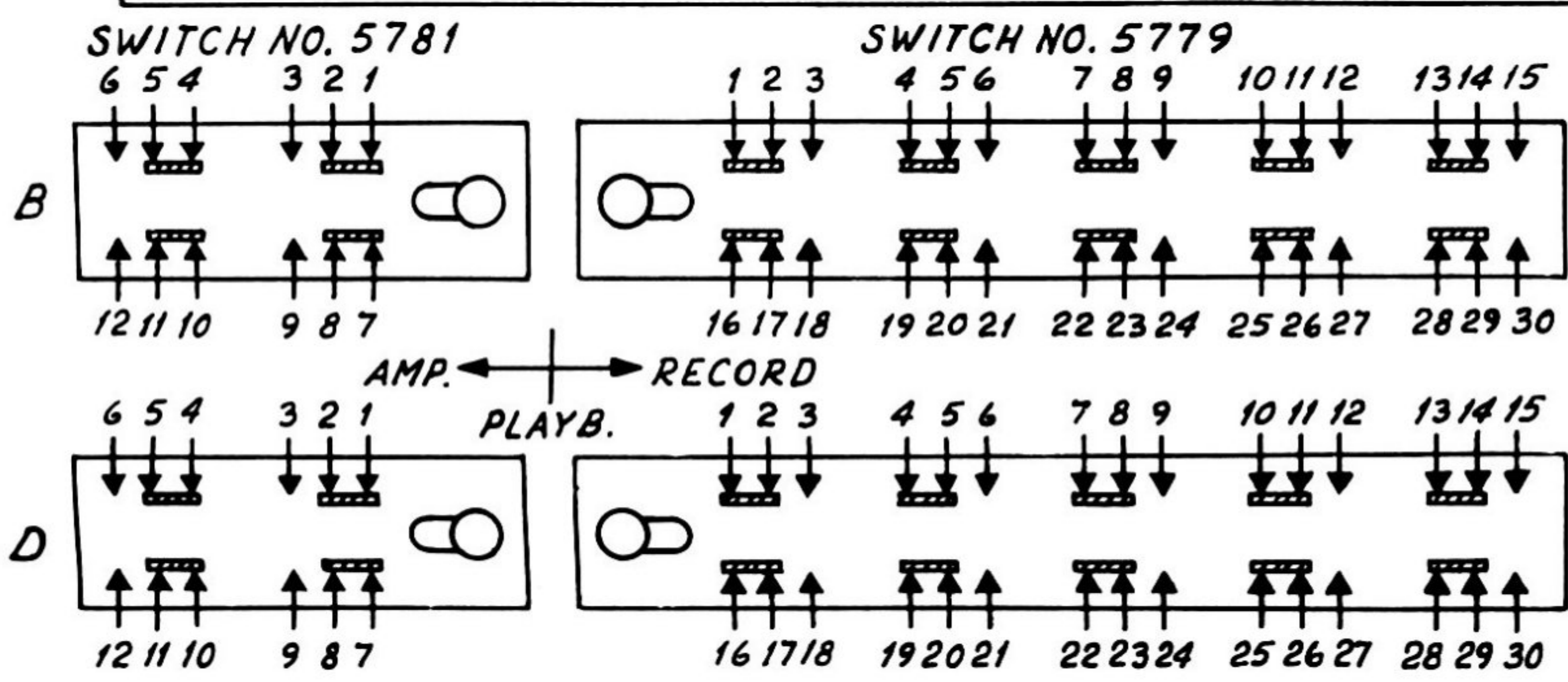

Fig. 65. The filter board 6356, component side.



RESISTANCES IN:
MOTSTAND I:
REC./PLAYB. HEAD ABOUT 140 OHMS
ERASE HEAD
L1
L2
L3
L4



SWITCHES IN PLAYBACK AND TAPE MOTION LEVER IN NEUTRAL.
ALL VOLTAGES - EXCEPT FOR V3, V6 AND V7 - ARE MEASURED IN THIS POSITION.

VENDERE I STILLING PLAYBACK OG BETJENINGSPAK I STILLING NØYTRAL.
ALLE SPENNINGER - UNDTATT FOR V3, V6 OG V7 - ER MÅLT I DENNE STILLING.

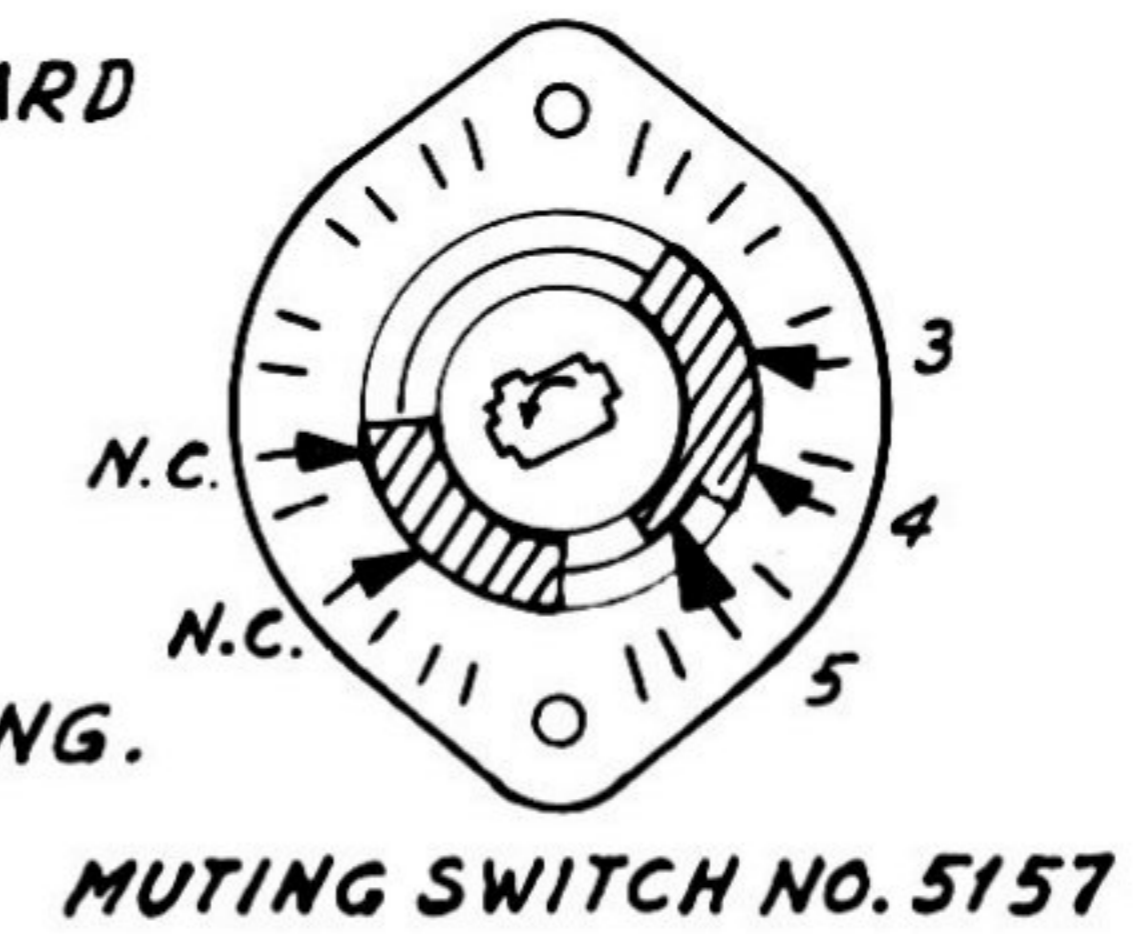

RESISTORS:
MOTSTANDER:
INDICATED IN OHMS.
ANGITT I OHM.
K = 1.000 OHMS.
M = 1.000.000 OHMS.
* = DEPOSITED CARBON RE.
KULLSKIKTMOTSTANDE
TOLERANCES ± 10 %.

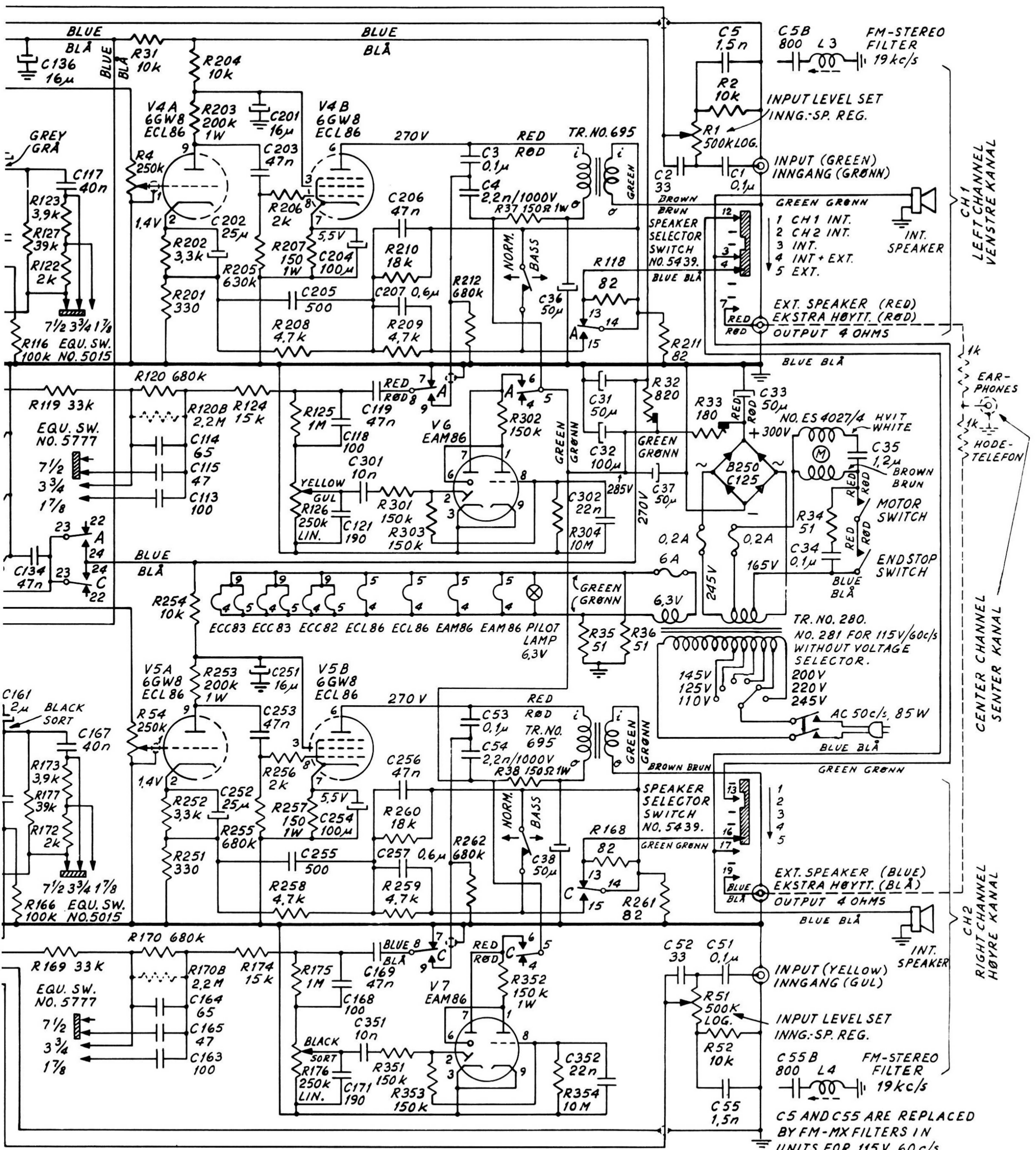

RESISTORS:
MOTSTANDER:
 INDICATED IN OHMS.
 ANGITT I OHM.
 K = 1.000 OHMS.
 M = 1.000.000 OHMS.
 * = DEPOSITED CARBON RESISTORS.
 KULLSKIKTMOTSTANDER.
 TOLERANCES ± 10 %.

CAPACITORS:
KONDENSATORER:
 INDICATED IN μμ FARADS.
 ANGITT I μμ FÅRAD.
 n = 1000 μμ F.
 TOLERANCES ± 20 %.
 C31, C32, C33 IN THE SAME CAN.
 C36, C37, C38 IN THE SAME CAN.

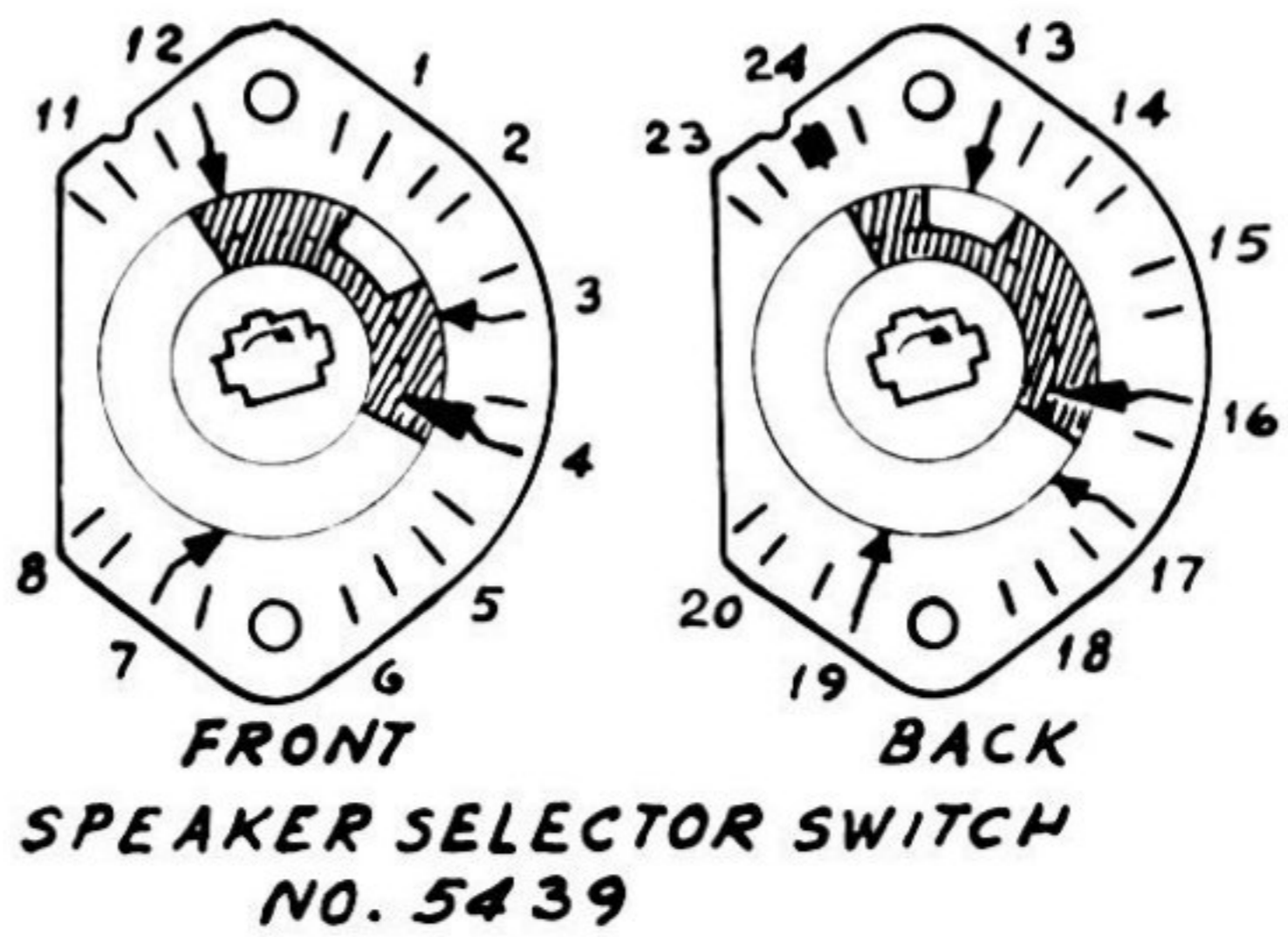

C5 AND C55 ARE REPLACED BY FM-MX FILTERS IN UNITS FOR 115V 60 c/s
 C5 OG C55 ER ERSTATTET AV FM-MX FILTERE I APP. FOR 115V 60 c/s

TANDBERG TAPERECORDER
 MODEL 74
 BELOW SER. NO. 711000
Fig. 66

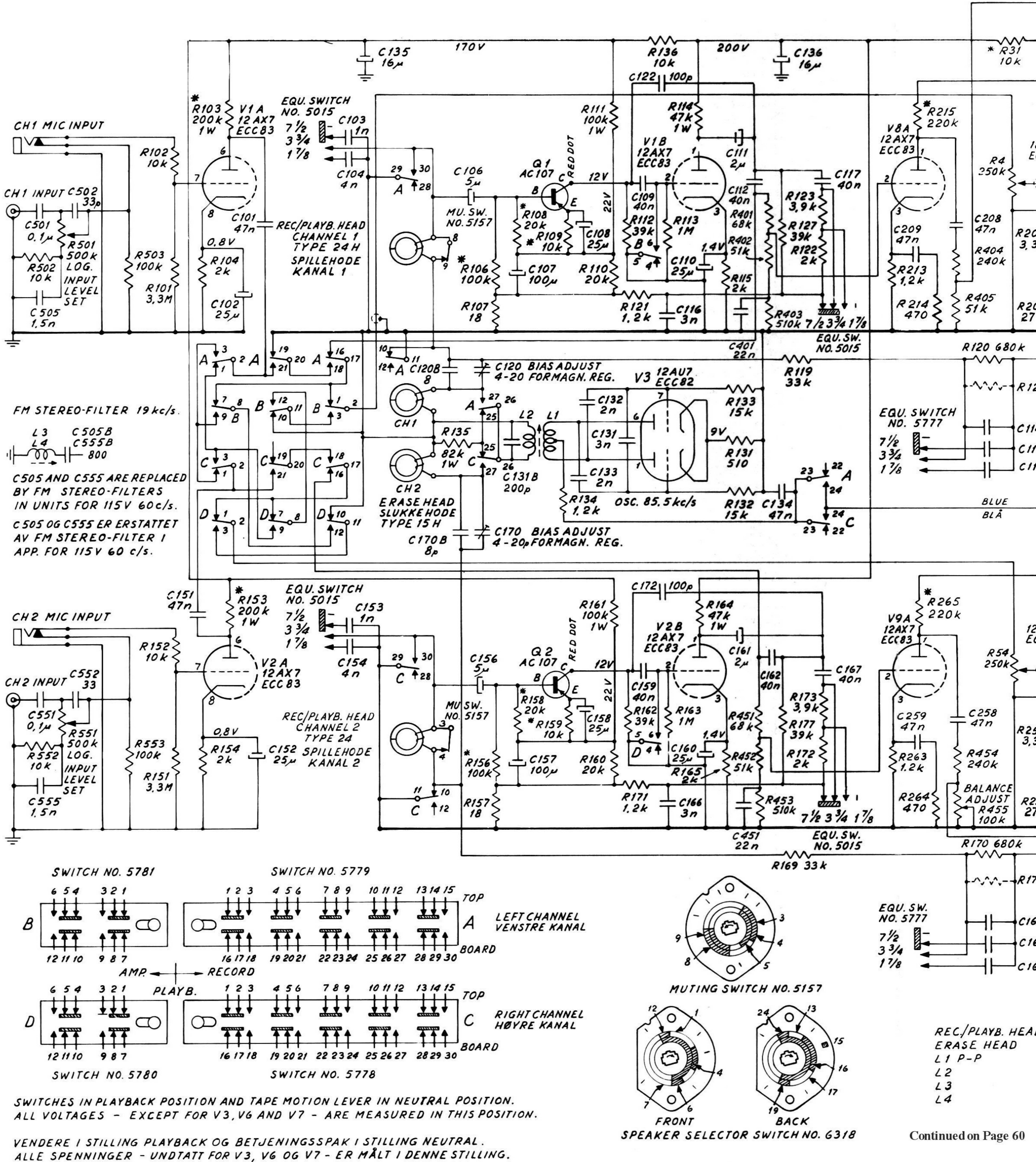

TANDBERG TAPE-RECORDER
 MODEL 74 B
 FROM SER. NO. 711000 TO 715000

Fig. 67

Continued on Page 60

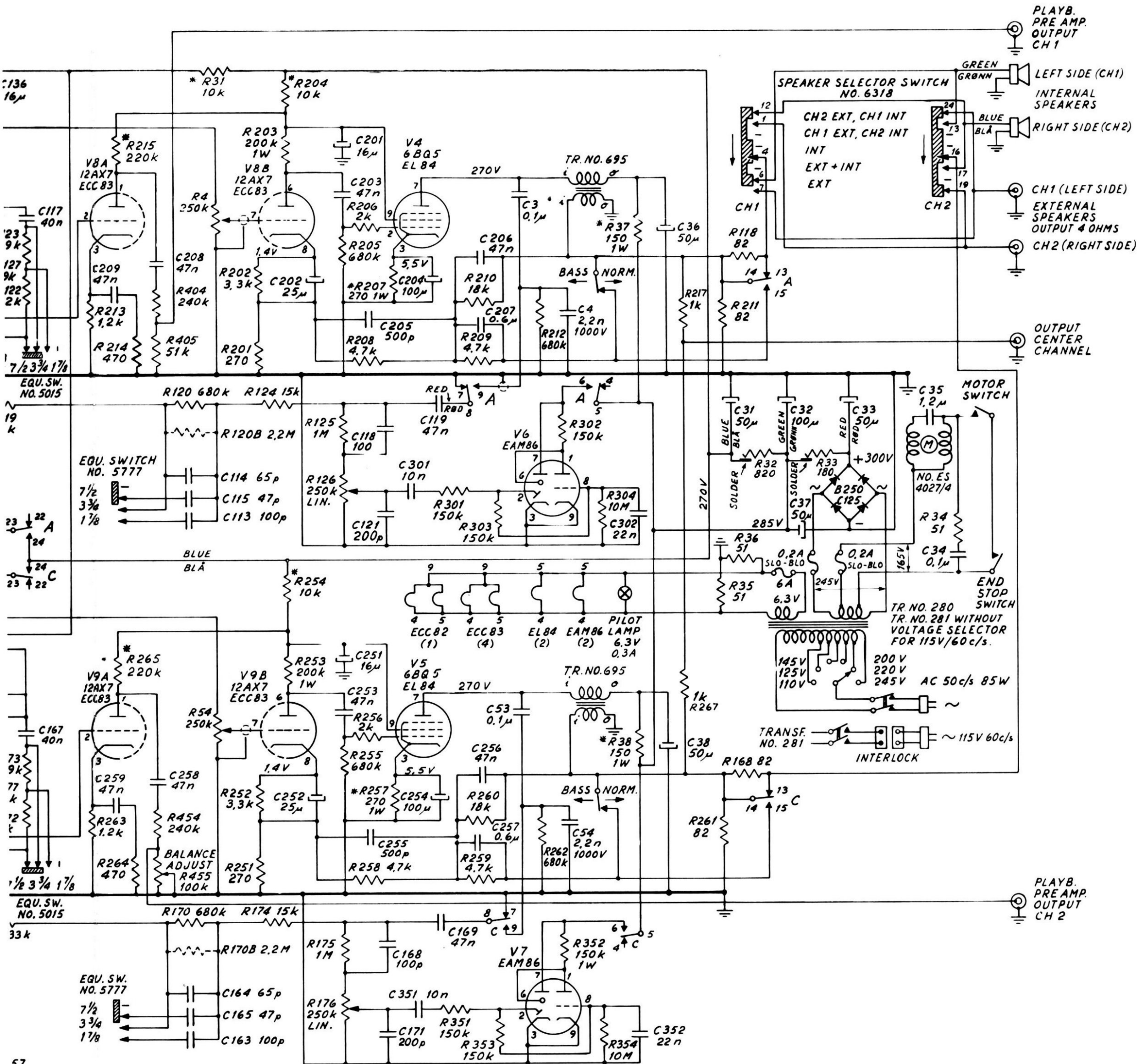

REC./PLAYB. HEAD ABOUT 140 OHMS.
 ERASE HEAD " 90 "
 L1 P-P " 30 "
 L2 " 12 "
 L3 " 75 "
 L4 " 75 "

RESISTORS ARE INDICATED IN OHMS. TOLERANCES $\pm 10\%$.
 MOTSTANDER ER ANGITT I OHM.
 k = 1,000 OHMS.
 M = 1,000,000 OHMS.
 * = DEPOSITED CARBON RESISTORS.
 KULLSKIKTMOTSTANDER.

CAPACITORS ARE INDICATED IN $\mu\mu$ FARADS. (pF)
 KONDENSATORER ER ANGITT I " "
 TOLERANCES $\pm 20\%$
 n = 1,000 $\mu\mu$ FARADS.
 C31, C32, C33 IN THE SAME CAN.
 C36, C37, C38 " " " "

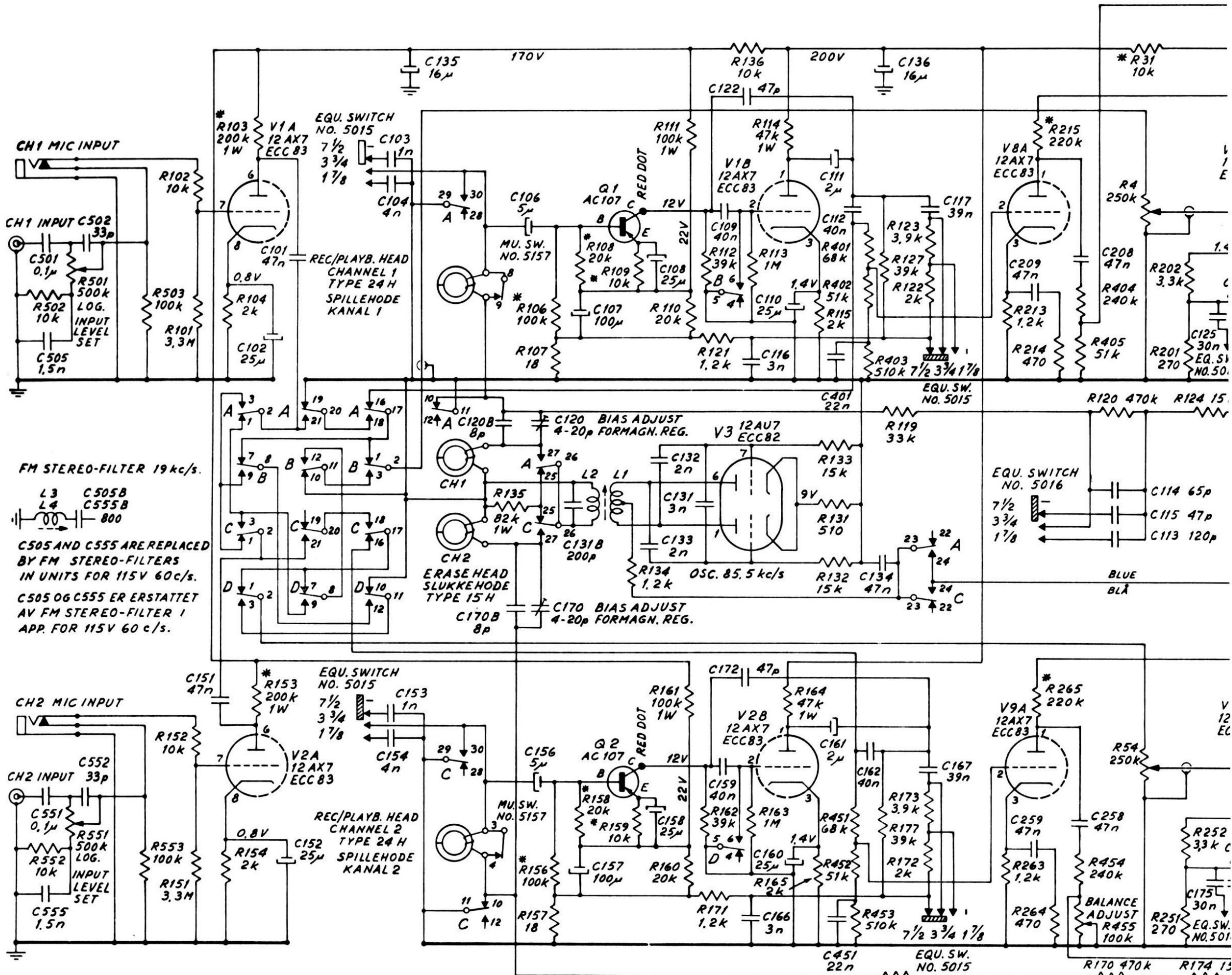

FM STEREO-FILTER 19 kc/s.
 L3 C505B
 L4 C555B
 800

C505 AND C555 ARE REPLACED BY FM STEREO-FILTERS IN UNITS FOR 115V 60 c/s.
 C505 OG C555 ER ERSTATTET AV FM STEREO-FILTER I APP. FOR 115V 60 c/s.

EQU. SWITCH NO. 5016
 7 1/2
 3 3/4
 1 7/8

BLUE
 BLÅ

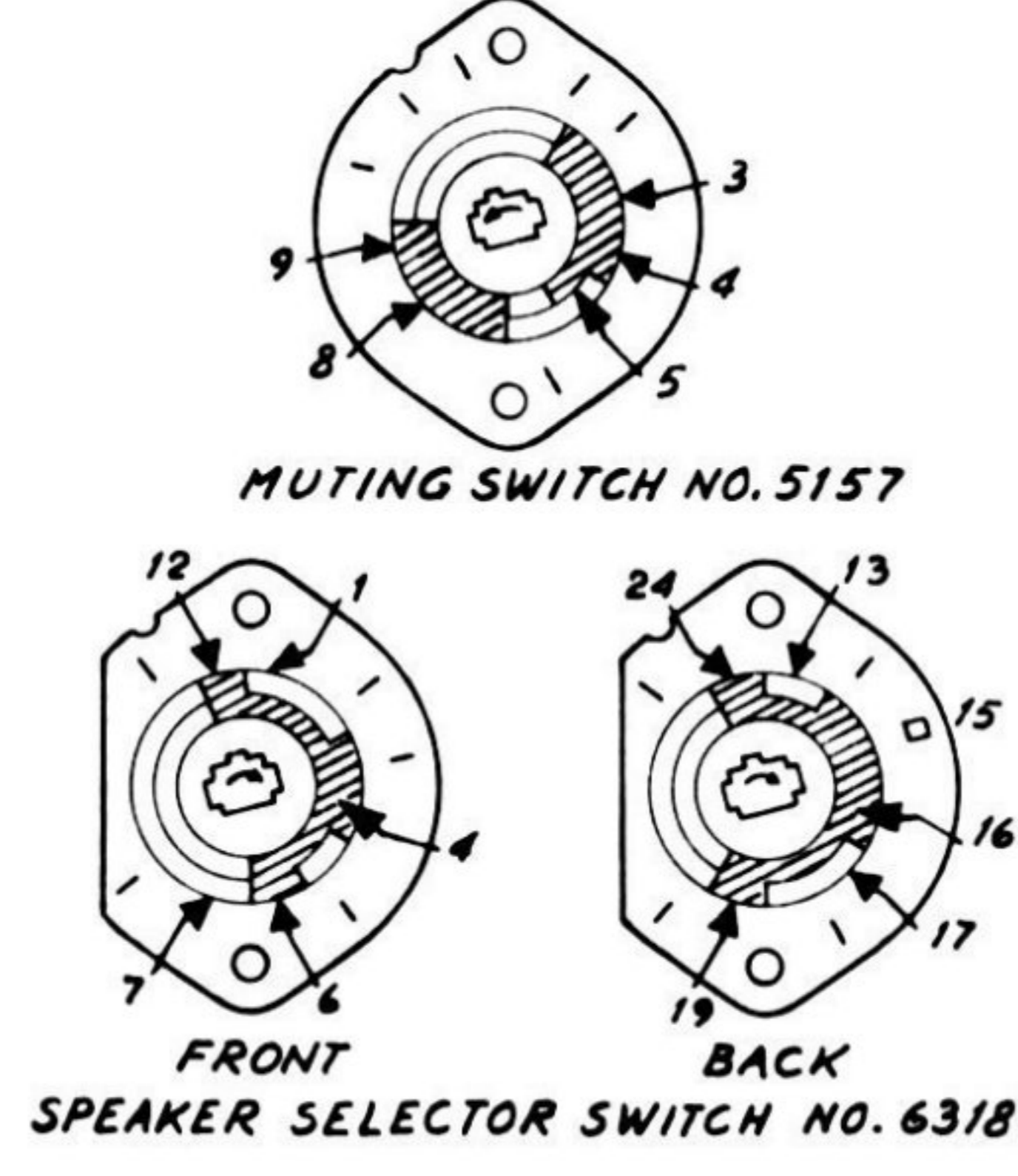
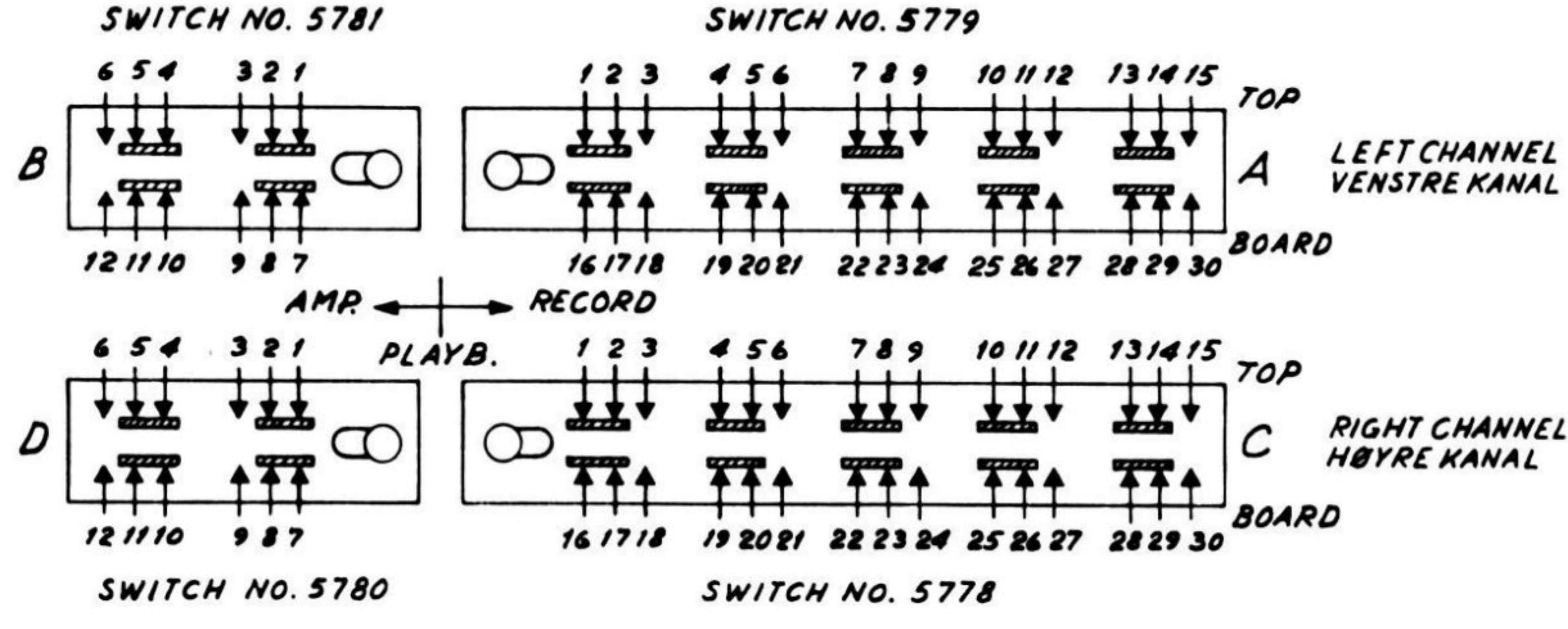

EQU. SW. NO. 5016
 7 1/2
 3 3/4
 1 7/8

REC/PLAYB. HEAD ABOUT
 ERASE HEAD " L1 P-P " L2 " L3 " L4 " L5 " L6 "

SWITCHES IN PLAYBACK POSITION AND TAPE MOTION LEVER IN NEUTRAL POSITION. ALL VOLTAGES - EXCEPT FOR V3, V6 AND V7 - ARE MEASURED IN THIS POSITION.

VENDERE I STILLING PLAYBACK OG BETJENINGSSPAK I STILLING NEUTRAL. ALLE SPENNINGER - UNDTATT FOR V3, V6 OG V7 - ER MÅLT I DENNE STILLING.

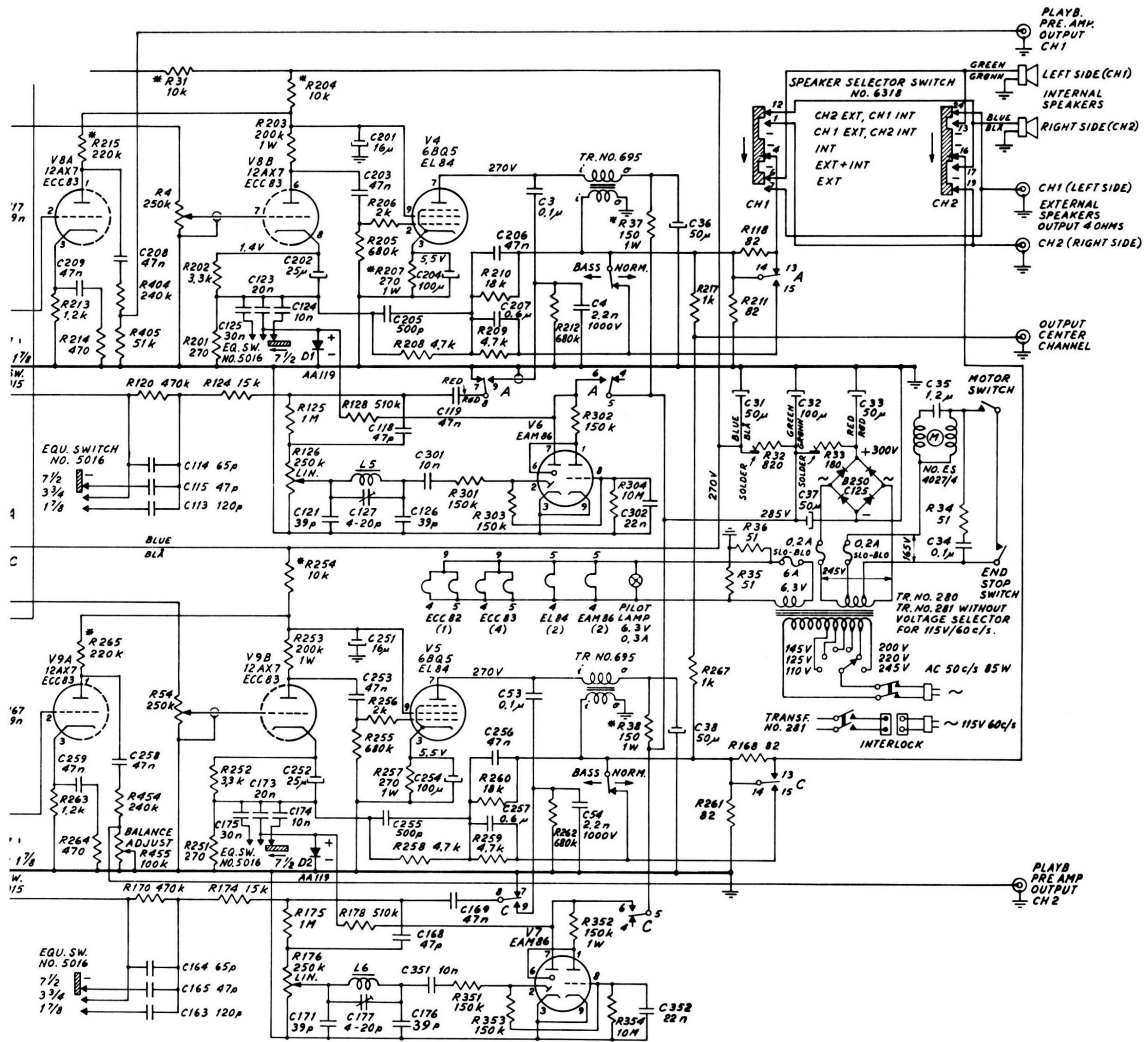

REC/PLAYB. HEAD ABOUT 140 OHMS
 ERASE HEAD " 90 "
 L1 P-P " 30 "
 L2 " 12 "
 L3 " 75 "
 L4 " 75 "
 L5 " 50 "
 L6 " 50 "

RESISTORS ARE INDICATED IN OHMS. TOLERANCES $\pm 10\%$.
 MOTSTANDER ER ANGITT I OHM.
 k = 1,000 OHMS.
 M = 1,000,000 OHMS.
 * = DEPOSITED CARBON RESISTORS.
 KULLSKIKT-MOTSTANDER.

CAPACITORS ARE INDICATED IN μ F FARADS (μ F).
 KONDENSATORER ANGITT I " " "
 TOLERANCES $\pm 20\%$.
 n = 1,000 μ F FARADS.
 C31, C32, C33 IN THE SAME CAN.
 C36, C37, C38 " " " "

TANDBERG TAPERECORDER
 MODEL 74B
 ABOVE SER. NO. 715001
Fig. 68
 Continued from Page 61

LUBRICATING

The motor:

The motor should be lubricated after approx. every 3000 hours of use.

The upper and the lower bearing should be lubricated with a Teresso oil 43 or 47 from Esso.

The self-lubricating bearings:

The turntables, the flywheel and the speed transfer wheel are mounted in self-lubricating bearings and should usually not be lubricated. If, however, it should be necessary to lubricate the bearings for any reason use Teresso oil 43 or 47 from Esso.

Note: Utmost care must be taken while lubricating, use only one fraction of a drop of oil for each bearing. Excessive oil might seriously affect the friction drive.

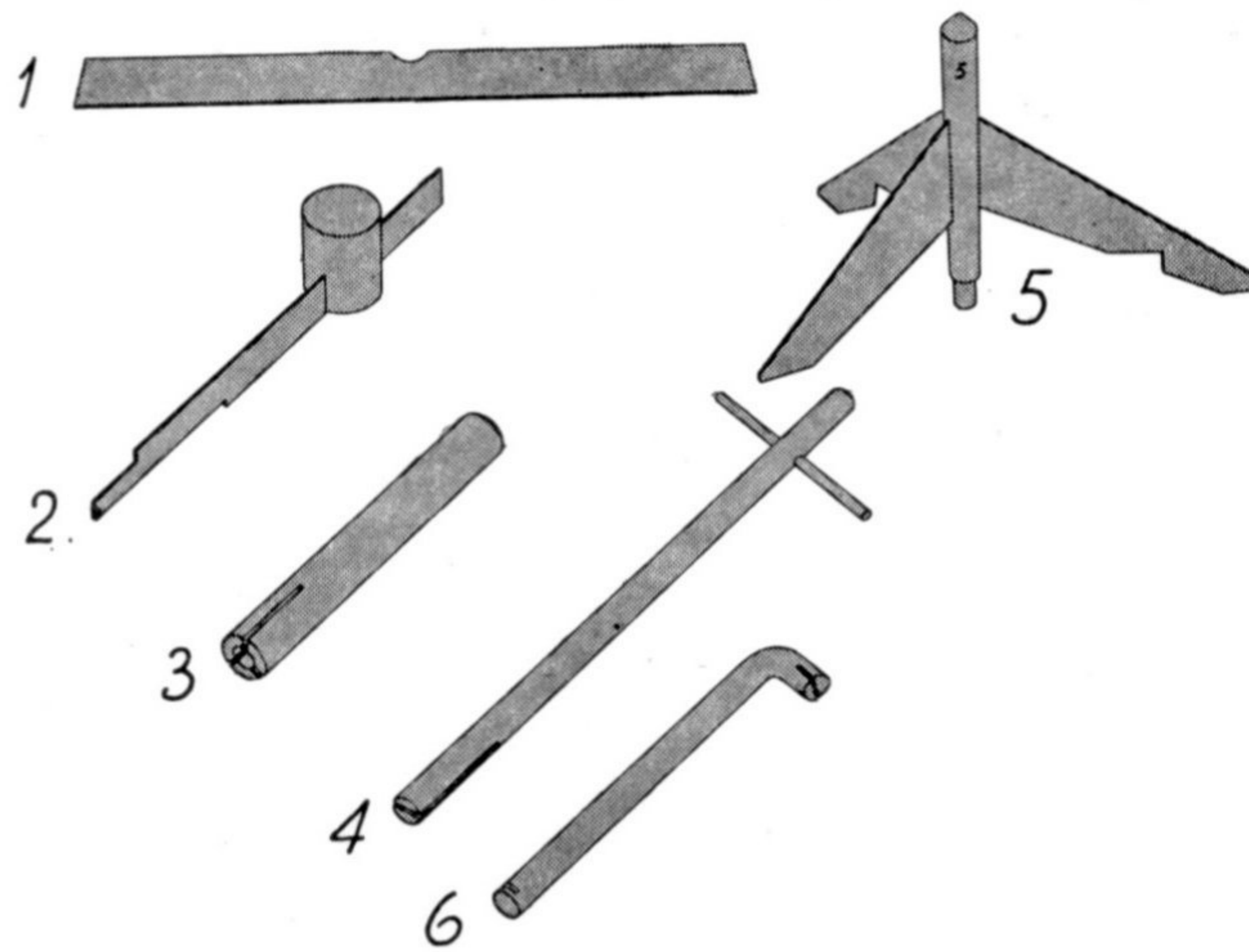

Fig. 69. The special tools.



S-39-10 65

J. Petlitz Boktrykkeri (Rolf Rannem), Oslo