



Operating Manual Series 4000 X

TANDBERG series 4000 X

Series 4000 X is a fully transistorized stereo tape recorder designed to satisfy the world's most discriminating markets with regard to quality, precision and reproduction fidelity. Application of the revolutionary Tandberg cross-field technique has extended the frequency range upwards and made the lower tape speeds more useful for high quality recording.

Series 4000 X has separate heads for recording and playback, rendering choice of A- or B-test monitoring and enabling sound-on-sound recording. The high-sensitivity microphone inputs are intended for dynamic microphones with 200–700 ohm impedance. A push-button selector adapts the pick-up amplifier for either magnetic or ceramic cartridge. Separate inputs and outputs are provided for connection of tuner or auxiliary amplifier. Fast-rise, slow-decay meter in each channel indicates the instantaneous programme level applied to the recording head.

Model 4000 X has two power output amplifiers, each one rated at 10 W. The bass- and treble controls are continuously variable, and separate volume controls are provided for each channel. These features make Model 4000 X a vital part in a music installation with a high quality record player and two Hi-Fi speaker systems. The recording can either be monitored in external or internal speakers or in headphones plugged into the jack on the top plate. In the latter case all speakers are disabled. A speaker selector provides choice of internal or external speakers or all speakers simultaneously.

With a lever, the tape can be brought into contact with the playback head during winding to enable cueing, which facilitates spotting of particular programme parts.

Series 4000 X more than adequately meets all the requirements of the Hi-Fi specifications of DIN 45500.

The U.S. as well as the Eu. models are prepared for modification to 4-channel stereo.

Contents

Tape	4
Power supply	4
Vertical mounting	4
Preparation for use	5
Connections	5
- Microphone	5
- Record player	5
- Stereo tuner or amplifier	5
- Speakers	6
- Headphones	6
Input selectors and level controls/Mixing ..	6
Function selectors and Normal/Special switch	7
Recording	8
Monitoring during recording	9
Playback	10
The tape recorder used as an amplifier	10
Combined playback/amplifier function	11
Sound-on-sound	11
- A-test	11
- AB-test	12
- Language training	12
4-track recording and playback	13
FM-MX-filter	14
Remote control of start and stop	14
Automatic stop	14
Erasure	14
Cueing—monitoring during fast winding	15
Copying of tapes	15
Programme editing	15
Tape splicing	16
Maintenance	16
- Inspection	17
- Cleaning	17
Connecting plugs	18
Microphone TM 5	19
Dust cover	19
Carrying case	19
Function summary—«Normal» operating modes	20
Function summary—«Special» operating modes	21
Block diagram	22
Technical specifications	23

Speed selector.

Front and rear head covers.

Instantaneous start/stop button.

Microphone sockets, channel L and R.

Record level indicators, channel L (left) and R (right).

Input selectors, channel L and R.

Input level controls, channel L and R, for record level, and for input level when used in amplifier mode.

Record buttons for channel L and R.

Cueing control for use during fast wind or rewind.

Playback buttons for channel L and R.

Speaker selector.

SPEAKER OUTPUTS 4Ω. DIN-sockets for connection of external speakers.

+27 V. Power supply for Tandberg FM-MX-filter. Socket is not provided on standard model.

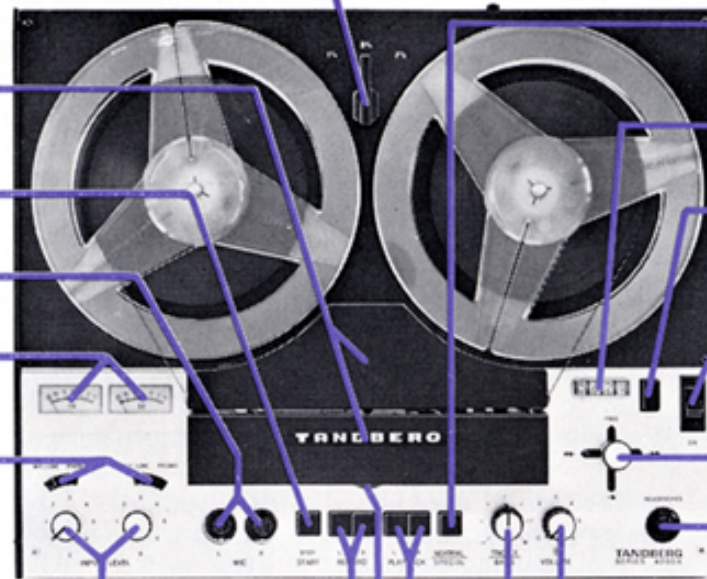

Normal/Special button, for sound-on-sound, combined playback/amplifier mode, etc.

Counter, indicates tape position.

Zero button for counter.

Mains switch. Power on is indicated by the counter being illuminated.

Operating lever for tape transport.

Stereo jack for headphones.

Volume controls, for headphones and loudspeaker level in playback, record monitoring and amplifier modes. Upper knob: Channel L (left). Lower knob: Channel R (right).

Tone controls. Upper knob: Treble. Lower knob: Bass.

LINE/RADIO. DIN-socket for recording/playback via tuner/amplifier.

Pick-up selector. Depressed: Magnetic (RIAA equalized). Released: Ceramic (or crystal).

PHONO. DIN-socket for record player input.

FOOT CONTROL TFC 2. Connection for remote control of start/stop.

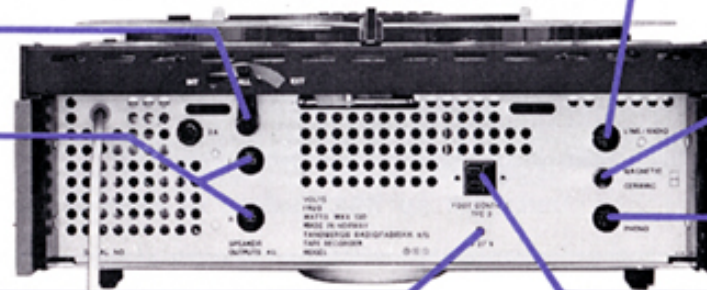

Tape

Tandberg tape recorder 4000 X is adjusted for recording on Low Noise tape, which gives a favourable signal-to-noise ratio. If ordinary tape is used for recording, the highest frequencies will be attenuated, re-

sulting in degradation of music reproduction. It is therefore recommended to use Low Noise tape for recording.

Power Supply

The tape recorder is set for operation on 230 V, 50 Hz but can easily be rewired for 115 or 240 V. Power consumption is maximum 130 W.

Note: Because of the automatic end-stop mechanism, the motor will not start until a tape has been properly inserted in the tape path. Wrong threading of the tape may prohibit starting.

Vertical mounting

The tape recorder can be used in horizontal or vertical position. For vertical operation, mount the legs furnished with the tape recorder on the front of the cabinet after first having removed the two screws. To prevent the tape reels from falling off or being displaced during operation, put the rubber knobs on the turntable spindles. The furnished rear cover will in vertical operation conceal the connecting cables and can be attached by pushing it into the grooves and sliding it towards the top plate.



Preparation for use

Connect the power cable to a socket with correct line voltage and set the power switch to ON. The tape recorder is now immediately ready for use. Put a tape reel on the left hand turntable so that it rotates counterclockwise when the tape is pulled out.

Thread the tape through the tape path and put the tape end into the slot on the tape reel. Set the operating lever in position FREE to let the tape reels rotate independently. Rotate the right hand reel counterclockwise until the tape is firm. Reset the counter.

Set the tape speed selector for the desired tape speed. 7 1/2 ips gives the best sound quality. The lowest tape speed should be used when tape economy rather than sound quality is the most important.

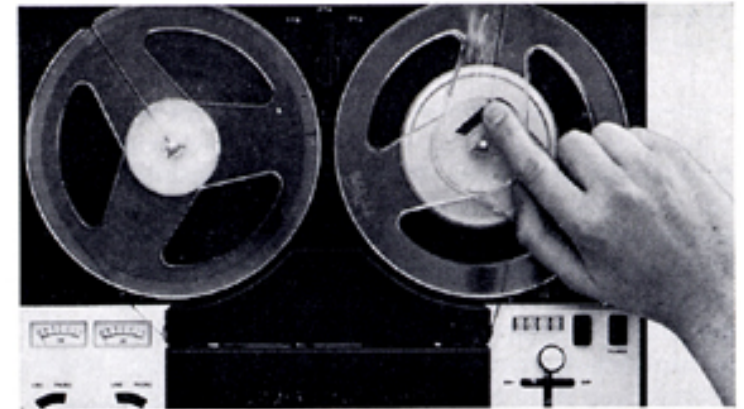

Connections

Microphone

For mono or stereo recording from microphone or when using the recorder as an amplifier, connect one or two microphones respectively to the DIN sockets MIC L and R on the top plate.

When recording in mono, signals from the two microphone amplifiers are merged and can be recorded on either channel. See paragraph on mixing.

For stereo recording, locate the microphone connected to MIC R to the right of the sound source and the one connected to MIC L to the left.

Note: When microphone is connected, corresponding signal from the LINE/RADIO connector is inhibited.

Record Player

Record player with magnetic-, crystal- or ceramic pick-up can be connected to the DIN socket PHONO. For use of magnetic pick-up, depress the pick-up selector

button to position MAGNETIC. The input amplifiers are then RIAA equalized. When using ceramic- or crystal pick-up, the selector button should be in released position, CERAMIC.

Stereo Tuner or Amplifier

For stereo recording or playback via tuner or amplifier, connect a 5-pole DIN cable from socket LINE/RADIO on the tape recorder to socket TAPE on the tuner/

amplifier. The cable will provide all connections necessary for recording and playback.

Speakers

Remote speakers with impedance 4–8 ohms should be connected to DIN sockets SPEAKER OUTPUTS 4 Ω , L or R. 4 ohm remote speakers will give optimal matching when used alone, while 8 ohm speakers will give optimal matching when used together with the internal speakers. Selection of internal- or remote speakers is accomplished with the selector at the rear, above the speaker sockets.

Note: Less than two ohm load impedance, or short-circuiting of the connecting leads, may cause damage to the output amplifiers if maximum volume is applied. If more than two speakers are needed for each channel, use combination of series and parallel connection.

Your dealer will no doubt be pleased to give you his advice on the problem.

Headphones

Headphones with minimum 200 ohm impedance for each channel can be connected to a stereo jack marked HEADPHONES on the top plate. When headphones are

connected, the output amplifiers with connected speakers are automatically disabled. Volume- and tone controls can be used normally.

Input selectors and level controls—Mixing

All signals fed to the tape recorder are controlled with separate input selectors and input level controls for each channel. The level controls (INPUT LEVEL) are used both for setting of record level, and for amplification when the recorder is used as an amplifier for record player or microphone.

When both input selectors are set to PHONO, input signals are supplied from record player via PHONO socket, and the input level is set with INPUT LEVEL R and L respectively. With the selectors in MIC/LINE, signals are supplied from the LINE/RADIO inputs or from MIC inputs if microphones are connected.

Note that insertion of microphone plug, automatically disconnects the corresponding LINE/RADIO input. Programme level is controlled with the corresponding INPUT LEVEL control irrespective of programme source. When one input selector is set to MIC/LINE while the other is in position PHONO, both channels from a connected record player are mixed and fed to the channel

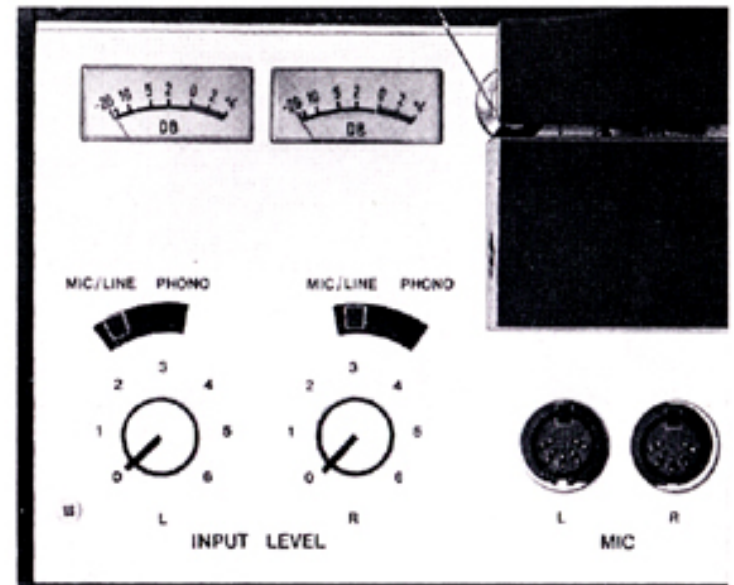

for which the input selector is in position PHONO. The level of the mixed programme containing both left and right channels from the record player (mono), is adjusted with the INPUT LEVEL control associated with the input selector that is set to PHONO. Correspondingly, the channel for which the input selector is in position MIC/LINE will be supplied with programmes from both microphones or from both LINE/RADIO inputs. If one microphone only is connected, programme from this microphone is mixed with programme from the other LINE/RADIO input. The level of the mixed programme is set with INPUT LEVEL associated with the input selector that is in position MIC/LINE.

It is furthermore possible to mix the two programmes which are separately controlled with their respective INPUT LEVEL controls when recording in mono. (Either RECORD L or RECORD R depressed.) The level of the composite programme being recorded is then indicated

on the meter for the recording channel only, but is dependent on the setting of both INPUT LEVEL controls.

The mixing possibilities when using the recorder as an amplifier are limited because the channels are separated in stereo amplifier mode, and right channel inputs are disconnected in mono amplifier mode (NORMAL/SPECIAL button depressed). It is, however, possible to set the recorder for mono recording and use A-test (See paragraph on monitoring). A-test can be performed without tape motion. The tape can even be removed from the tape path in order to stop the motor (automatic end-stop). In both cases, one of the record buttons must be depressed and the operating lever must be in normal forward drive position. Don't forget to return the operating lever to centre position after use.

Function selectors and Normal/Special switch

These switches control the main functions of the recorder. The most frequently used functions, such as mono and stereo recording and playback, stereo amplifier mode and monitoring of recording are obtained with the NORMAL/SPECIAL switch in released position and by combinations of the record and playback buttons (RECORD L and R, PLAYBACK L and R).

When the NORMAL/SPECIAL switch is depressed, a few special functions can be performed, such as Sound-on-Sound, combined playback/amplifier mode, and recording with simultaneous A- and B-test (without the echo effect being recorded). The various functions are summarized on pages 20 and 21.

Note: For convenience, programmes controlled with left INPUT LEVEL control are in the following referred to as **L input**, whereas those program-



mes controlled with right INPUT LEVEL are referred to as **R input**.

Recording

Mono

Connect auxiliary equipment as explained in chapter on connection. Set the START/STOP button in STOP position (released). Select programme with input selectors. For recording on left channel, depress RECORD L (RECORD R for right channel) while moving the operating lever to position →. Left or right indicator will be illuminated.

Set recording level with the appropriate INPUT LEVEL control(s). If programme is fed via one of the input controls only, the one not used should be set to zero. Programme level should be set for a meter indication up to the red sector (0 dB) during the strongest passages of the signal. Excessive signal level will give distortion, whereas too low level will result in an unfavourable signal-to-noise ratio.

Reset the counter.

Start the recording by depressing START/STOP button. The recording can be interrupted or terminated by releasing the START/STOP button. For longer stops, move the operating lever to centre position. The RECORD button will then be released.

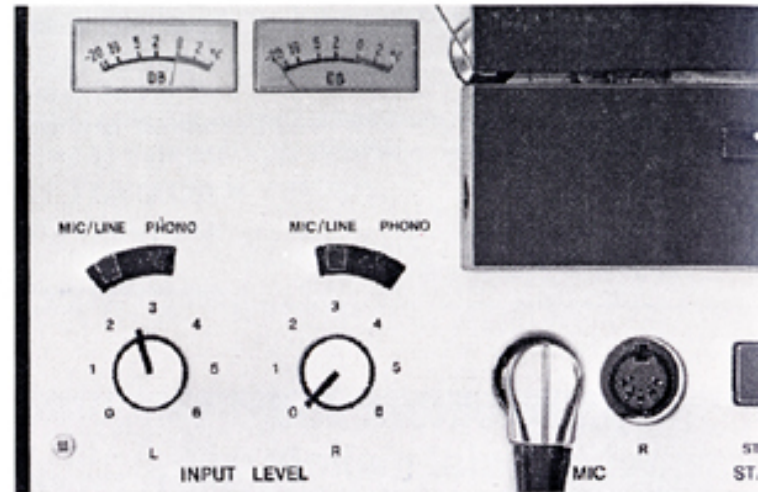

Stereo

Connect the programme as explained in chapter on connection, page 5. The procedure for stereo recording is the same as for mono, except for the following: Depress both RECORD buttons (L and R). Both record level indicators will then be illuminated and the programme level for each channel is set with the corresponding INPUT LEVEL knob.



Monitoring during recording

It is usually desirable to monitor the programme while it is being recorded. Two types of monitoring exist. The programme can be monitored at the input of the record amplifier (A-test). The separate heads for recording and playback also allow B-test, which implies that the recorded signal is monitored via playback head and amplifier.

Both monitoring methods have particular advantages. In A-test, the monitored and input programmes are syn-

chronous, and monitoring can even be done without tape motion. B-test monitoring can only be performed during normal tape motion and is delayed with respect to the input programme owing to the distance between recording and playback heads. B-test is the safest method, as the entire recording and playback process is checked. By switching between A- and B-test it can be checked that there is no difference in programme quality before and after recording on the tape.

Mono

A-test of recorded programme is possible when both PLAYBACK buttons are in released position, B-test when PLAYBACK button for recording channel is depressed.

In both cases the programme is fed to the outputs of both channels. The use of volume and tone controls are as for playback.

In mono recording it is possible to perform A-test via outputs of the recording channel and B-test via outputs of the other channel. The PLAYBACK button for the recording channel and NORMAL/SPECIAL button must then be depressed. Owing to the delay in B-test, an echo effect varying with the tape speed will occur.



Note that when NORMAL/SPECIAL button is depressed, programme fed via right INPUT LEVEL control is inhibited.

Stereo

A-test when both PLAYBACK buttons are in released position.

B-test when both PLAYBACK buttons are depressed.

The two stereo channels are fed separately to the left and right outputs respectively. Volume and tone controls have the same effect as for playback.

If only one of the playback buttons is depressed during stereo recording, the outputs of both channels will be furnished with B-test programme from the reproducing



channel.

Playback

Mono

As desired, connect speakers, headphones, tuner or auxiliary amplifier as explained in chapter on connection, page 5. Use the counter to locate the particular programme part to be played back, or utilize the cueing feature, see chapter on cueing, page 15. Check that the START/STOP button is in released position. Depress the PLAYBACK button for the desired channel and move the operating lever to position →. Playback is started by depressing the START/STOP button, which can also be used for shorter pauses in the playback. The reproduced programme is fed to the outputs of both channels, and the level in speakers or headphones is set with VOLUME L for left channel and VOLUME R for right channel. The bass and treble controls are common for the two channels. Tonal balance and volume for programme played back via auxiliary amplifier or radio connected to socket LINE/RADIO, must be controlled on the connected tuner/amplifier.



Return the operating lever to centre position when playback has been finished.

Stereo

The procedure for stereo playback is the same as for mono playback except that both PLAYBACK buttons (R and L) must be depressed.

The two channels of the stereo programme are then fed separately to right and left outputs respectively.

The tape recorder used as an amplifier

The tape recorder is excellent for use as an amplifier for microphone, record player or other programme sources.

Stereo

RECORD, PLAYBACK, and NORMAL/SPECIAL buttons must be in released position. Connect the programme source and set the input selectors as for recording. Tentatively set the INPUT LEVEL controls to position 3–4, and adjust volume and tone controls as desired. Avoid coincidence of a too low setting of the input level controls and too high setting of the volume controls or vice versa. Programmes from the two channels are fed separately to the left and right outputs.

Mono

Two methods exist for operating the tape recorder in the mono amplifier mode.



If the function selectors are set as for stereo amplifier mode and the NORMAL/SPECIAL button is depressed, programmes supplied via right level control is inhibited and programmes from left channel inputs are fed to both output amplifiers. Output volume is set separately with VOLUME controls for the two channels.

If a mono amplifier with mixing possibilities is required, set the tape recorder for mono recording

with A-test for both channels. To prevent the motor from starting, remove the tape from the tape path or leave the START/STOP switch in STOP position. Use of input

selectors and input level controls for mixing is explained in separate chapter page 6. Volume and tone controls are used as in stereo amplifier mode.

Combined playback/ amplifier function

It is possible to play back from one channel while using the other channel as a mono amplifier. Connect the amplifier programme to inputs associated with left INPUT LEVEL control.

Programme fed via right level control is inhibited in the combined playback/amplifier mode.

Depress NORMAL/SPECIAL button and PLAYBACK L button for playback from left channel, or PLAYBACK R button for playback from right channel.

Reproduced signal is fed to outputs for reproducing channel, amplified programme to the outputs of the



other channel. Tone- and volume controls are used as for mono playback or mono amplifier.

Sound-on-Sound

A-test

Sound-on-Sound is a technique allowing a programme played back from one channel to be mixed with another programme and recorded on the other channel.

As shown in figure, it is assumed that the original programme is recorded on channel L. This programme is played back and fed via an internal connection to the input amplifier of channel R. Another programme from a microphone is fed to input amplifier of channel L. When recording in mono (RECORD R depressed), both programmes will be mixed and recorded on channel R. In order to synchronize the programmes, and to adjust the relative signal levels, the mixed programme is monitored in headphones connected to SPEAKER OUTPUT R (A-test). B-test can not be used for this purpose owing to the time delay between recording and playback of the mixed programmes on channel R.

The states of the function selectors are shown in the figure. The input selectors are set to obtain adjustment

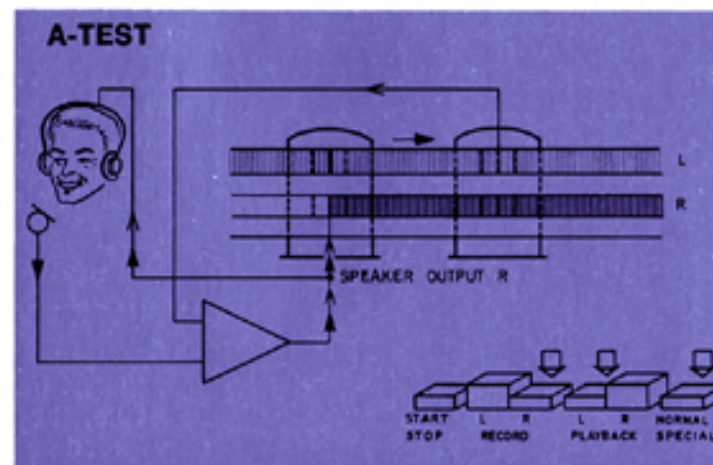

of the external programme by means of INPUT LEVEL L. The level of the primary programme transferred from channel L to channel R, is adjusted with INPUT LEVEL R. The level of the composite programme is indicated by

right record level indicator. Headphones are connected to SPEAKER OUTPUT R (A-test of mixed programme) or to SPEAKER OUTPUT L (primary programme only). If stereo headphones are connected to the socket HEADPHONES, the primary programme will be heard in the left headphone and the secondary programme in the right channel.

Output volume in speakers or headphones is set with volume L and R.

If speakers are used instead of headphones, the volume controls must be turned down to avoid acoustic feedback.

Sound-on-Sound recording on channel L is accomplished in a similar way. See table on page 21.

AB-test

Sound-on-Sound recording in AB-test is the same as for A-test except that the playback button for the recording channel is also depressed. To ensure high quality recording with monitoring in B-test, two persons are needed. The one singing or playing the secondary programme listens to the pre-recorded programme with headphones connected to SPEAKER OUTPUT L (A-test). The output level is adjusted with VOLUME L. The other person listens to the programme in headphones connected to SPEAKER OUTPUT R (B-test), after it has been mixed and recorded. The volume is adjusted with VOLUME R. Switching between A and B-test to ensure optimal recording quality is performed by operating the PLAYBACK R button. The relative levels of the two programmes and the input level of the composite programme are set by the monitoring operator. Sound-on-Sound recording in AB-test on channel L is performed in a similar way. See table on page 21.

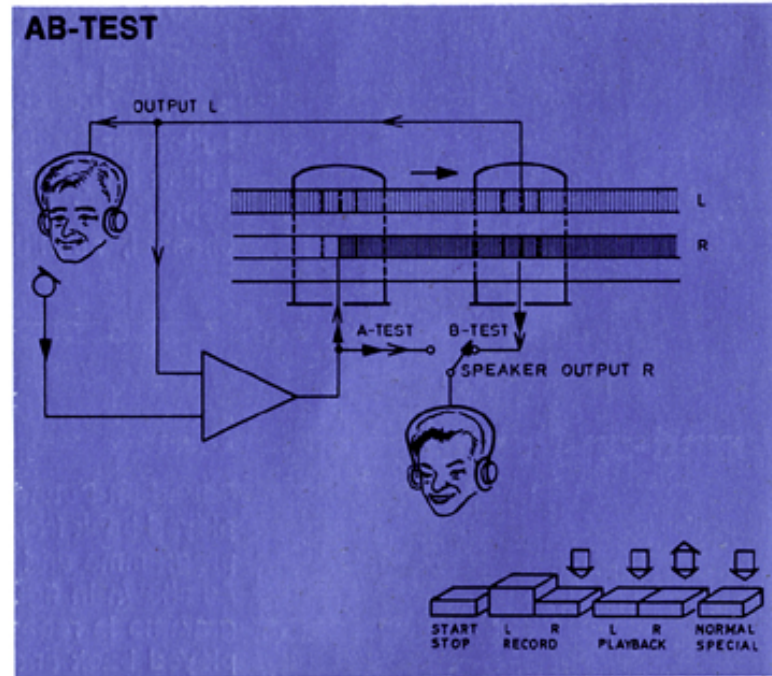

LANGUAGE TRAINING

The Sound-on-Sound A-test technique may also be used for language training. In the following summary of the procedure, the master programme is assumed to be prerecorded on left channel (track 1), while the student response is recorded on right channel (track 3).

Connections and presettings

Connect mono headphones to the SPEAKER OUTPUT R socket, and microphone to one of the MIC sockets.

Set left input selector to MIC/LINE, and right selector to PHONO. Right INPUT LEVEL, controlling transfer of master programme to student track, should be set to approx. 4. Left INPUT LEVEL, controlling the student microphone level, should be set for a deflection up to 0 dB on the record level indicator, when speaking into the microphone during recording. Also adjust VOLUME R (lower knob), and bass and treble controls, for desired headphone level. Depress NORMAL/SPECIAL, PLAYBACK L, and START/STOP buttons.

Procedure for recording and monitoring of student response:

Depress RECORD R and move operating lever to →. Listen to master programme, and repeat during pauses. Master programme as well as student response is recorded on the student track (right channel). Work through a suitable part of the lesson, and rewind the tape to the beginning (observe the counter). Depress PLAYBACK R, and return the operating lever to normal forward drive position. The student track, con-

taining both master programme and student response, is then reproduced through the headphones. When the entire programme part has been played back, move the operating lever to centre position, release the PLAYBACK R button, and continue with next part of the lesson as explained above.

Note: Be careful not to operate the left record button (RECORD L), to avoid erasure of the master programme.

Four-track recording and playback

This chapter applies for the four-track version of Model 4000 X only.

Recording

Recording can take place on four separate tracks equally spaced across the width of the tape, with track 1 uppermost when playing from one end of the tape (defined as side 1), and track 4 uppermost when playing from the opposite end (side 2).

With RECORD L depressed and side 1 up, track 1 is recorded. When the tape has run through, put the full reel on the left turntable and continue with RECORD L depressed. Recording then takes place on track 4. If RECORD R button is depressed, track 3 will be recorded on side 1, and track 2 on side 2.

Playback

In mono playback, side 1 of the tape gives a choice between tracks 1 and 3 by depressing buttons PLAYBACK L and R respectively. Side 2 gives the choice of tracks 4 and 2 respectively.

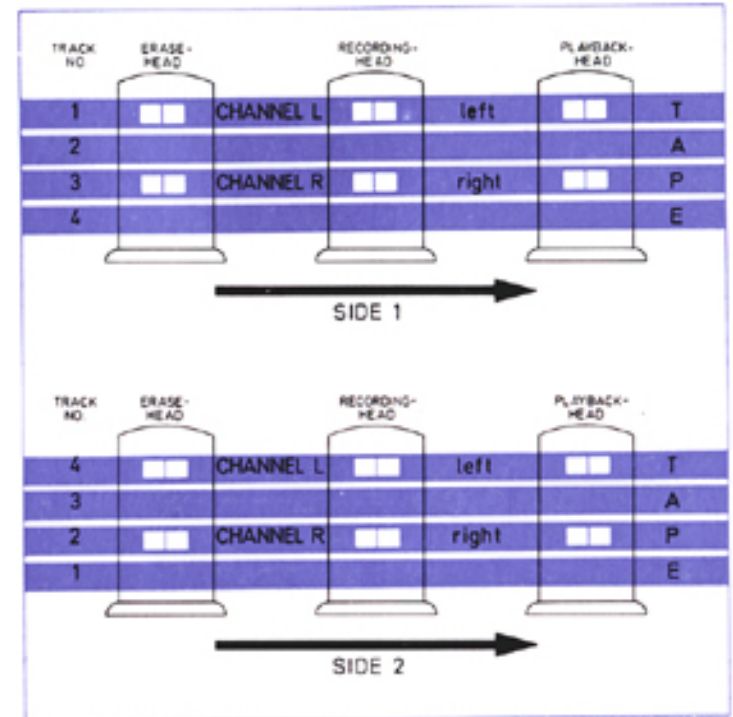

FM-MX-Filter

Tandberg FM-MX-Filter is specially designed for use with Tandberg tape recorders. The filter is active and requires a supply voltage of 27 volts. An output for 27 volts can easily be mounted if it is found that FM stereo broadcast to be recorded is disturbed by pilot tone interference.

Connection of FM-MX-Filter

Connect the DIN plug on the filter cable to the socket LINE/RADIO on the tape recorder and special plug to the socket +27 V. Connect a DIN cable from the socket TAPE or DIODE on the tuner to the socket RADIO on the FM-MX-Filter. If the tuner is equipped with phono sockets, connect two phono leads from DIODE or TAPE on the tuner to FILTER INPUT L and R on the FM-MX-Filter.

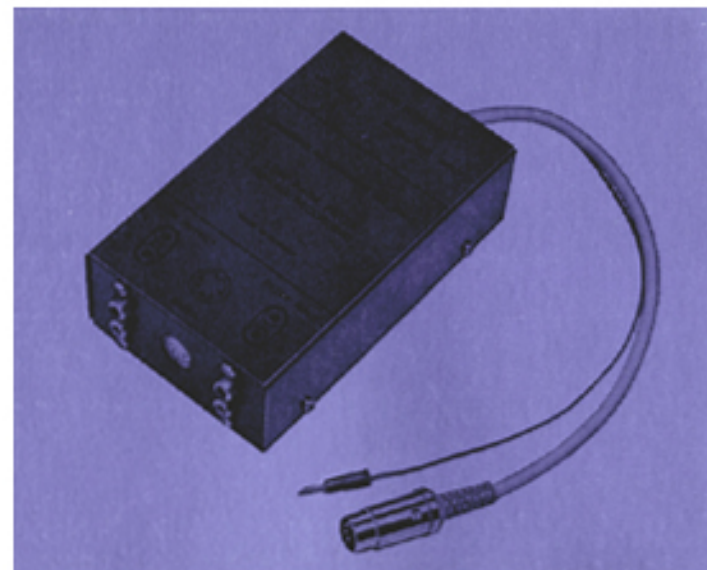

Remote control of start and stop

In record and playback modes, Model 4000 X can be started and stopped instantaneously with a foot pedal connected to the socket FOOT CONTROL TFC 2, pins 1 and 3. When a foot pedal is to be used, the START/STOP

button must not be depressed. The tape recorder starts when the pedal is depressed and stops when the pedal is released.

Automatic stop

A switch located in the right tape guide post will operate at the end of tape or if the tape snaps. Motor and turntables will then stop.

Owing to this end stop mechanism, the motor will not start until a tape has been correctly inserted into the tape path.

Erasure

When a new programme is recorded on one or two tracks, already existing programmes on these tracks are automatically erased. If it is desirable to erase a

programme without recording a new one, run the tape through in record mode with the INPUT LEVEL controls in counterclockwise position.

Cueing – monitoring during fast winding

During forward and reverse winding, the tape can be brought into contact with the playback head by operating the cueing control. When in addition the PLAYBACK button for the desired channel is depressed, the programme can be heard in speakers or headphones or via auxiliary tuner/amplifier.

Owing to the high winding speed, the sound will change character. Nevertheless the cueing is quite useful for spotting of particular programme parts on the tape.



Copying of tapes

The short DIN-cable, which is furnished with Model 4000 X, is an adapter to be used when copying from one recorder to another. Connect the copying adapter and the ordinary DIN cable together between the LINE/RADIO sockets of the two recorders. Either one of the recorders can be used for recording of programme from the other one.

In the special case when a Tandberg Model 6000 X is used for the master tape, the copying adapter can be

omitted, and the ordinary DIN cable can be connected between LINE socket on Model 6000 X and LINE/RADIO socket on 4000 X.

Note: The copying adapter must be used for interconnection of tape recorders only. It must also be observed that both recorders are not set for record or amplifier mode simultaneously.

Editing

A recorded programme does not always have the sequence desired for playback of the programme. Editing of the tape can then be accomplished by cutting and splicing of the tape.

Play back and listen to the programme. Stop the tape at the desired spot by means of the START/STOP button. With the operating lever in position →, take hold of the tape at the right hand guide post and pull it out to the right hand side of the power switch. The tape should now be cut at the right hand guide post.



Tape splicing

For editing purposes, or if the tape has snapped, the ends must be spliced.

Lay the ends of the tape over each other with the same side of the tape facing upwards. Cut the tape with scissors or knife (non-magnetic) at an angle of about 45 degrees.



Lay the tape ends against each other, shiny side up. Lay the splicing tape across the join, parallel to the cut, and press firmly, squeezing out any air bubbles.



Cut the splicing tape along both edges. The cut should curve slightly into the edge of the recording tape to prevent adhesive on the splicing tape from being deposited on the magnetic heads.



Note: Adhesive tape which is not expressly intended for splicing of recording tapes must under no circumstances be used.

Maintenance

When using the tape recorder, dust and particles from the tape will deposit on heads and guide posts. The coating will cause reduced signal-to-noise ratio and impaired treble reproduction, and may also cause drop-outs. Inspection and cleaning of the tape path should be performed regularly, before the symptoms become noticeable. It is highly recommended to use tape of the best quality because these tapes, in addition to giving a better sound reproduction, also leave less deposits and

cause less wear of the heads. Cleaning should be performed at intervals of 50 to 100 hours of operation, dependent of tape quality, temperature, amount of dust in the environments etc.

Cleaning and lubrication of motor and tape drive mechanism should only be performed at an authorized service station at intervals of approximately 3000 hours of operation (corresponding to more than 4 months continuous operation).

Inspection

Remove the front head cover by depressing the spring loaded buttons at both ends, and lifting the cover straight upwards. The operating lever should be in centre position. The back cover can be lifted off when the button on its rear side is depressed. Inspect for contamination of the parts shown in the figure. Pay particular attention to the sharp corners of the tape guide posts where deposits tend to settle (tape edge). Replace the head covers.

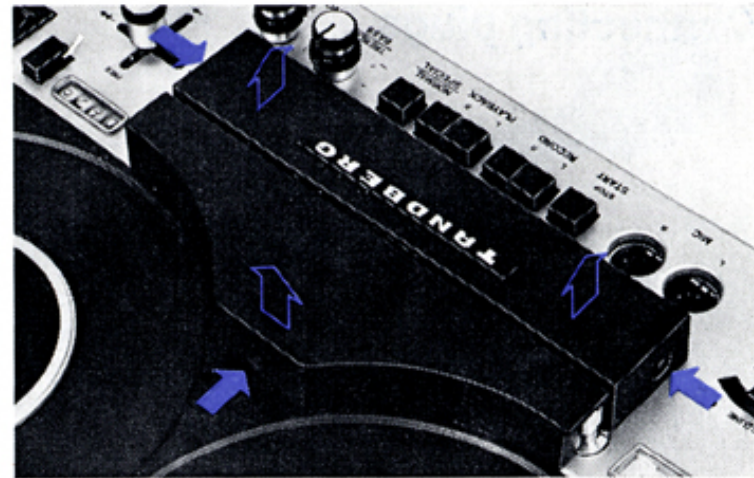

Cleaning

The cleaning can be done with cotton wool or a piece of flannel, wrapped around a small stick, and moistened with pure alcohol or benzin. A kit intended for this purpose, «Tandberg Professional Tape Head Cleaner», containing a number of plastic pins with cotton (Q-tips) and a bottle with nonflammable cleaning liquid is available. Solvents, such as acetone or trichlorethylene must not be used, as these may damage the heads. Clean at the spots indicated in figure.

1. Fixed guide post.
2. Adjustable guide post.
3. Pressure pad support.
4. Pressure pad.
5. Erase head.
6. Record head.
7. Playback head.
8. Bias (crossfield) head.
9. Flutter roller.
10. Capstan.
11. Pressure wheel.
12. Tape brake.
13. Fixed guide post with feeler for the automatic end stop.

The plush pad pressing the tape against the tape rest must not be moistened, as this will upset the friction conditions. Cleaning of the plush pad should be done with a dry brush.

Note: Care should be taken, not to disturb the position of heads or guide posts.

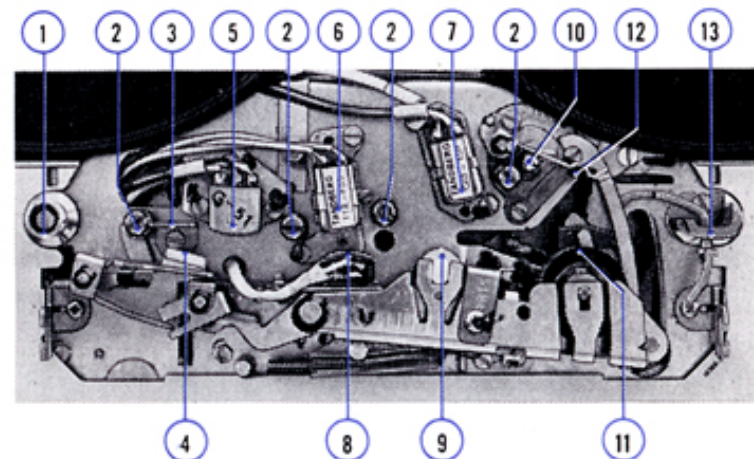

Connecting plugs

MIC

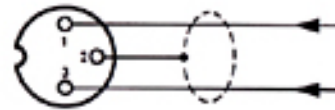

1. Signal from microphone.
2. Shield.
3. Signal from microphone.

Pins 1 and 2 are interconnected on the socket.

PHONO

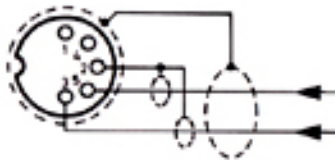

2. Common lead.
5. Signal from pick-up, right channel.
3. Signal from pick-up, left channel.

The outer shielding, which is usually connected to the record player's chassis, should be connected to the plug's metal housing, and not to the common lead.

Pins 1 and 5 are interconnected on the socket.

LINE/RADIO

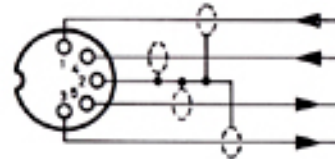

1. Signal from tuner/amplifier, left channel.
4. Signal from tuner/amplifier, right channel.
2. Common lead (shielding).
5. Signal to tuner/amplifier, right channel.
3. Signal to tuner/amplifier, left channel.

SPEAKER OUTPUTS

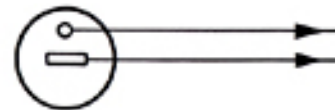

Signal to external speaker (4–8 ohms).
(Flat pin to chassis.)

FOOT CONTROL TFC2



Start (closed)/stop (open).

HEAD- PHONES

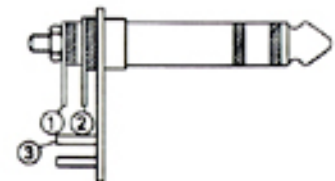

1. Channel L.
2. Channel R.
3. Common lead (shielding).

Note: The plugs are seen from the wiring side.

Microphone TM5

Tandberg TM5 is a dynamic microphone with high sensitivity in an omnidirectional pattern. The sensitivity to contact sounds and blowing noises is negligible.

TM5 is especially designed for reporting purposes and for recording of song and music. The frequency response is very flat, with an intentional roll-off at lower frequencies to reduce low frequency reverberation and noise.

The connector at the end of the metal housing is fitted with a lock to prevent the plug from being pulled out.

Specifications:

Frequency range: 90–13 000 Hz, ± 3 dB. Sensitivity at 1000 Hz: 0.2 mV/ μ bar. Impedance: 600 ohms. Length: 165 mm. Diameter: 34 mm.



Dust cover

A grey-toned transparent dust cover, available in robust plastic can be used for both vertical and horizontal mounting of the tape recorder.

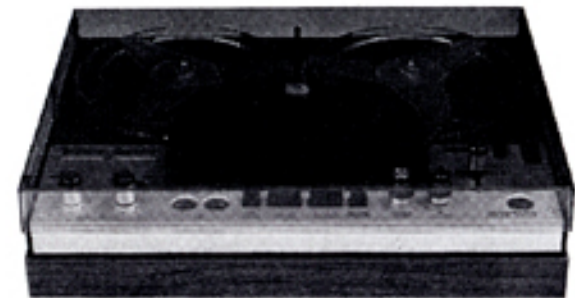













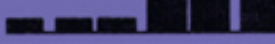

Carrying case





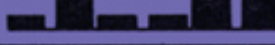



Carrying case Model 5 is an attractive, practical and rugged transport case for tape recorder 4000 X. Place the front of the recorder in the case, towards the side marked front. The case is fitted with locks and weighs 2.3 kg (5 lbs).

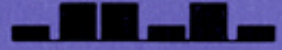

Function summary - "NORMAL" operating modes

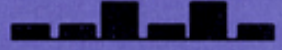
Mode of operation	Setting of function buttons 	Programme at outputs	
Stereo amplifier		From left and right inputs, respectively	Operating lever in any position, with or without tape in the tape path
Mono recording ch L with monitoring		Same programme at both channels: A-test: Playback button released B test: Playback button depressed	L and R inputs mixed
Mono recording ch.R with monitoring		Same programme at both channels: A-test: Playback button released B test: Playback button depressed	L and R inputs mixed
Mono playback ch. L.		Played back programme at all outputs	
Mono playback ch. R.		Played back programme at all outputs	
Stereo sound recording with monitoring		A-test both channels at L and R outputs, respectively	
		B-test both channels at L and R outputs, respectively	
		B-test channel R at all outputs	
		B-test channel L at all outputs	
Stereo playback		Played back programmes at L and R outputs respectively	
Mono recording ch. L with or without monitoring, and mono playback ch. R		Played back programme (channel R) at all outputs	L and R inputs mixed
		Channel L: B-test recorded programme Channel R: Played back programme	
Mono recording ch.R with or without monitoring, and mono playback ch. L		Played back programme (channel L) at all outputs	L and R inputs mixed
		Channel L: Played back programme Channel R: B-test recorded programme	

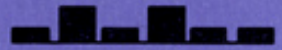
Function summary—“SPECIAL” operating modes

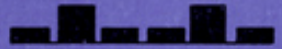
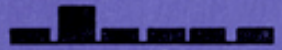
Mode of operation	Setting of function buttons 	Programme at outputs	Remarks
Mono amplifier		From left input at all outputs	Operating lever in any position, with or without tape in the tape path
Mono playback ch. L and mono amplifier ch. R		Channel L: Played back programme Channel R: Amplified programme from L inputs	R inputs disconnected
Mono playback ch. R and mono amplifier ch. L		Channel L: Amplified programme from L inputs Channel R: Played back programme	R inputs disconnected
Mono recording ch. L with simultaneous A- and B-test		A-test recorded programme at all outputs	As the corresponding NORMAL-function, but with R inputs disconnected
		Channel L: B-test recorded programme Channel R: A-test recorded programme	R inputs disconnected
Mono recording ch. R with simultaneous A- and B-test		A-test recorded programme at all outputs	As the corresponding NORMAL-function, but with R inputs disconnected
		Channel L: A-test recorded programme Channel R: B-test recorded programme	R inputs disconnected
Sound-on-sound with recording on ch. L		Channel L: A-test recorded (mixed) programme Channel R: Played back programme	Previously recorded programme on channel R is played back and, via an internal connection, fed to channel R's input. L inputs are supplied with programme from external source. Mono recording on channel R then implies that both programmes (controlled with INPUT LEVEL L and R respectively) are mixed and recorded on this channel.
		Channel L: B-test recorded (mixed) programme Channel R: Played back programme	
Sound-on-sound with recording on ch. R		Channel L: Played back programme Channel R: A-test recorded (mixed) programme	Previously recorded programme on channel L is played back and, via an internal connection, fed to channel R's input. L inputs are supplied with programme from external source. Mono recording on channel L then implies that both programmes (controlled with INPUT LEVEL L and R respectively) are mixed and recorded on this channel.
		Channel L: Played back programme Channel R: B-test recorded (mixed) programme	

NOTE THAT:

- if a programme is to be recorded or amplified in stereo, both input selectors must be set to same position (ref. page 6).
- when the NORMAL/SPECIAL button is depressed, all programmes applied to the tape recorder via right input level control are disconnected.

Block diagram Series 4000 X

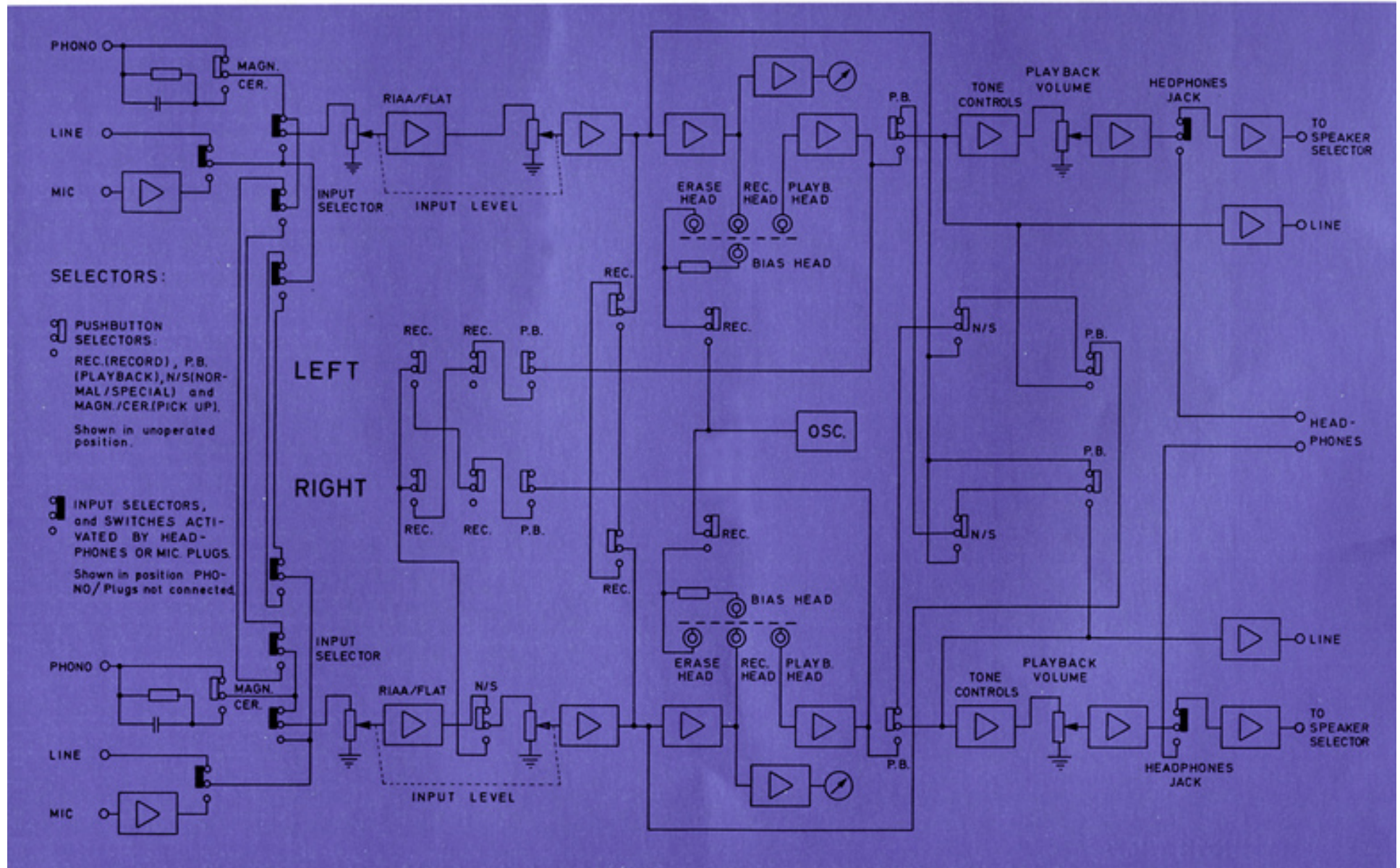

Technical specifications:

Mains voltage: Standard model: 230 V/50 Hz. Can be rewired for 115 or 240 V. U.S. model: 115 V, 60 Hz. Can be rewired for 220 V or 240 V.

Power consumption: Maximum 130 Watts.

Motor: 2-pole asynchronous.

Tape: Maximum reel diameter: 7". Low Noise Tape should be used for recording.

Tape speed: 7¹/₂, 3³/₄, 1⁷/₈ ips.

Speed tolerance: 1.5 %.

Fast forward and reverse winding:

1200 ft tape, 7" reel: 1 min. 45 sec.

1800 ft tape, 7" reel: 2 min. 10 sec.

Heads: Erase head, record head, playback head, bias head (Tandberg Cross Field). 2 or 4 tracks.

Erase and bias frequency: 85.5 kHz. Distortion less than 0.5 %.

Record level indicator: Moving coil instrument. Deflection to 0 dB corresponds to 3 % tape distortion.

Inputs: Each channel has the following inputs:

1. Microphone input, unbalanced (MIC, DIN-socket), for dynamic microphone with impedance 200–700 ohms. Sensitivity: 70 μ V. Maximum input level: 70 mV.
2. Line input (LINE/RADIO, DIN-socket). Impedance: 50 kohms. Sensitivity: 5 mV. Maximum input level: 15 V.
3. Pick-up input (PHONO, DIN-socket). Pushbutton selector for ceramic/crystal or magnetic cartridge (RIAA equalized).

Magnetic: Impedance: 33 kohms. Sensitivity: 1.5 mV. Maximum input level: 3 V. (At 1000 Hz.)

Ceramic: Impedance: Matched for ceramic cartridge. Sensitivity: 10 mV. Maximum input level: 30 V. (At 1000 Hz.)

Outputs:

Each channel has the following outputs:

1. Speaker output (SPEAKER OUTPUTS 4 Ω , DIN-socket). Speaker impedance: 4–8 ohms. Optimal matching is obtained when using 8 ohms remote speakers together with the internal speakers, or when using 4 ohms remote speakers alone.
Maximum output power: 10 watts.
2. Line output (LINE/RADIO, DIN-socket). Minimum load impedance: 5 kohms. Output level, unloaded: 0.75 V for a tape recorded at 0 dB deflection on the record indicator.
3. Headphone output (HEADPHONES, stereo jack), for stereo headphones with impedance minimum 200 ohms per channel. Output level: Dependent on volume- and tone controls setting.

Speakers: Internal speakers: 4" x 7", impedance 8 ohms. Power fed to the internal speakers is limited to 5 watts per channel. To obtain maximum output power, 2 x 10 watts, 4 ohms external speakers should be connected.

Bass and Treble controls are continuously variable, and affect programmes fed to speakers or headphones only. The bass and treble controls are common for the two channels.

Bass: \pm 15 dB at 100 Hz.

Treble: \pm 15 dB at 10 000 Hz.

Transistors: 61.

Distortion, at 400 Hz, maximum:

From record amplifier, at 0 dB record level: 0.5 %.

From playback amplifier, at 0.75 V playback level: 0.3 %.

From tape recorded at 0 dB record level: 3 %.

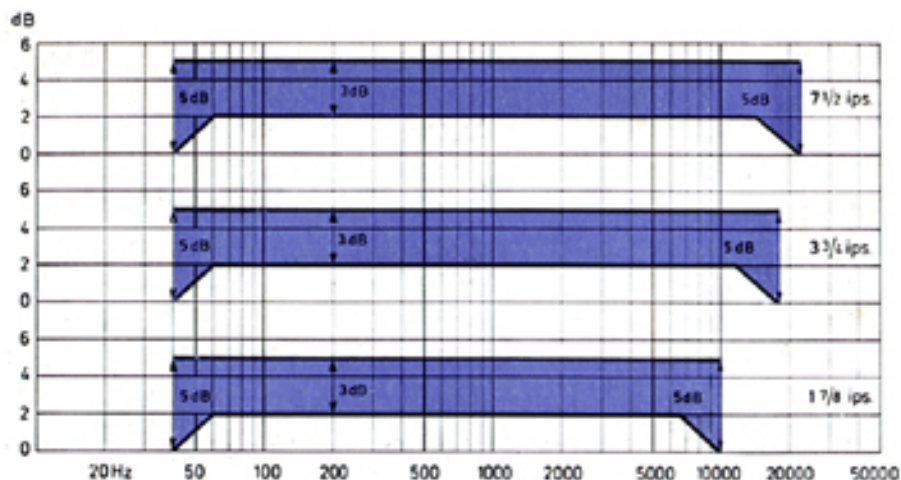

The coloured sectors indicate tolerance areas for total frequency response measured according to DIN 45511.

Wow, maximum:

R.M.S.	According to DIN 45511 (peak):
7 1/2 ips: 0.07 %	0.1 %
3 3/4 ips: 0.14 %	0.2 %
1 7/8 ips: 0.28 %	0.4 %

Crosstalk suppression: Measured at 1000 Hz, according to DIN 45511:
 Mono > 60 dB Stereo > 50 dB

Frequency response:

Referred to 400 Hz: According to DIN 45511:

7 1/2 ips: 40–20 000 Hz ± 2 dB	7 1/2 ips: 40–22 000 Hz
3 3/4 ips: 50–16 000 Hz ± 2 dB	3 3/4 ips: 40–18 000 Hz
1 7/8 ips: 50– 9 000 Hz ± 2 dB	1 7/8 ips: 40–10 000 Hz

In amplifier mode: 30–18 000 Hz ± 3 dB.

Signal/Tape Noise measured at 7 1/2 ips and 5 % tape distortion, minimum:

	4-track	2-track
Geräuschspannung (peak value, DIN 45511)	54 dB	56 dB
Fremdspannung (peak value, DIN 45511)	51 dB	51 dB
IEC A-curve (R.M.S.)	62 dB	64 dB
Linear (R.M.S.)	57 dB	57 dB

Dimensions: Length: 15 1/2" (39.4 cm). Height: 6 1/2" (16.5 cm). Depth: 12 3/8" (31.6 cm).

Weight: 20 lbs (9.5 kilos).

Modification to 4-channel stereo, Eu. and U.S. models:

Modification to 4-channel playback head and installation of additional playback amplifiers is prepared, and may easily be performed by an authorized service station.

TANDBERGS RADIOFABRIKK A/S

Kjelsåsveien 161 – Oslo – Norway



Tandbergs Radiofabrikk A/S, Kjelsås. Tandbergs Radiofabrikk A/S, Kjeller.

DEALER: